



831C/D-2

1.25/2.5 KILOWATT
FM TRANSMITTER

P R E L I M I N A R Y
I N S T R U C T I O N B O O K



**Rockwell
International**

Collins Radio Group

If You Didn't Get This From My Site,
Then It Was Stolen From....

www.SteamPoweredRadio.com

Bill Elledge

831C/D-2
1.25/2.5 KILOWATT
FM TRANSMITTER
P R E L I M I N A R Y
I N S T R U C T I O N B O O K



CONTENTS

		<u>Page</u>
I.	Forward	1
II.	Technical Description	2
III.	Adjustment Procedure	11
IV.	Typical Meter Readings	
	831D-2	12
	831C-2	13
V.	Efficiency Curves	
	831D-2	14
	831C-2	15
VI.	Transformer Connections	16
VII.	Remote Control Connections	17
VIII.	Installation Diagram	18
IX.	Parts Lists	19
X.	Schematic	20

I. FORWARD

These preliminary instructions are issued prior to delivery of your 831C/D-2 Instruction Book. The book is in process and will be mailed to you as soon as available. Of special interest please note:

- A. The transmitter has been adjusted to deliver 1.25/2.5 kW when the power scale reads 100%. (Unless specified otherwise.)
- B. The transmitter was tested on 230 volts, therefore, all connections are on the 230 volt transformer taps. Please refer to Section VI for proper connections for your line voltage.
- C. On installation allow at least 2 foot clearance on each side and rear of transmitter for adequate air circulation and for ease of servicing.

II. TECHNICAL DESCRIPTION

The Collins 831C/D-2 FM transmitter is housed in a single cabinet which utilizes a steel frame with removable rear and side panels. Access is from the front for exciter modules, control circuit cards and the PA tube and from the front and rear for all other components.

Electrical interlocks for the control circuits and shorting switches for high voltage circuits are located behind the grid and plate circuit access panels for the power amplifier, behind the control card access panel, and behind the front and rear access panels for safety purposes.

For purposes of this description the transmitter will be divided into the following sections:

- A. 310Z-2 FM Exciter
- B. Power Amplifier
- C. Control Circuits
- D. Power Supplies
- E. Control and Metering

A. 310Z-2 FM Exciter:

See 310Z-2 Instruction Book.

B. Power Amplifier:

A single 5CX1500A pentode operated Class C is used in the power amplifier. A nominal drive level of 20 watts is required from the Type 310Z-2 FM exciter for full rated output power. A conventional capacitor-tuned tank circuit and L section provides impedance matching between the 50 ohm output of the 310Z-2 exciter and the power amplifier grid circuit. The suppressor grid of the 5CX1500A is connected to chassis ground and provides sufficient isolation between the input and output circuits to preclude any requirement for neutralizing circuits.

The output circuit consists of a capacity loaded quarter-wave cavity with a motor driven tuning and coupling capacitors. A teflon sandwich type blocking capacitor is connected between the outer circumference of the PA tube anode and the inner conductor of the cavity to preserve the coaxial integrity of the network. Coarse adjustment of the cavity is accomplished through the use of an adjustable sliding partition at the top of the compartment.

The power amplifier is operated grounded-cathode with the screen grid near RF ground through bypass capacitors. A protective bias voltage is applied through a diode which is gated off by a bias voltage developed by a grid leak resistor under normal operating conditions. The protective bias prevents over dissipation of the power amplifier tube in the event of drive loss. The gated diode prevents the bias supply ripple voltage from contributing to the output noise level.

The RF output from the plate tank circuit couples to the harmonic filter, which consists of two series-resonant, M-derived, low-pass end sections and a constant K, T center section. Maximum attenuation occurs at the main carrier second harmonic frequency. The plate tank circuit and the harmonic filter together provide at least 77 dB attenuation to all main-carrier harmonics through the 10th harmonic.

The directional coupler provides DC analog voltage samples of the forward and reflected power for the power control circuits and for VSWR trip overload.

C. Control Circuits:

The control circuits of the Collins 831C/D-2 transmitters utilize, for the most part common 7400 Series TTL integrated circuit logic for most control functions.

A1A1 Control Circuit Card

The basic ON/OFF and overload circuits are contained on a single plug-in card located in the front panel card cage of the transmitter and designated A1A1 on the accompanying schematic. Integrated Circuit U1 is a

four section NOR gate used as an inverter for filament and plate ON/OFF commands. When a "filament on" command is applied to pin 15 of the card, the output of U1A goes to a low state which sets flip-flop U2A and causes the Q output to rise to a high level. This output is routed to NAND gate U3A and NOR gate U5A. The output of U5A is directly coupled to both inputs of U5B which inverts the output of U5A and causes the output to go to a high state which appears on pin L of the card. This circuit is connected to the Control and Power Supply Assembly A2. Transistor Q6 on the A2 assembly turns on and energizes relay K1 which turns on the blower and the primary of a regulator transformer for the power amplifier filament supply. When the blower comes up to speed, air pressure switch A1A6 S7 closes and completes a circuit to pin 12 of the A5A1 card. This is a high input which combines with the high output from U2A to produce a low output at U3A. This low output is then fed to NAND gate U3B and timer U6. NAND gate U3B is used as an inverter to feed a high signal to Q4 on the A2 assembly. Transistor Q4 serves as a current amplifier to fire a triac Q5 which turns on the PA Tube filament.

The timer U6 operates as a plate on time delay, its output being fed to one input of a flip-flop formed by U3C and U3D. When the time delay has elapsed, an input to NAND gate U7A is readied in the high state. Two other inputs must also be in the high state for the plate supply to be energized. These are the interlock input via pin D of the card and the plate on input from flip-flop U2B. Flip-flop U2B must be set by application of a "Plate On" Command via pin 13 of the connector before the plates can be turned on. If all three inputs of gate U7A are in a high state, its output will be low and will be inverted by U7B. The output of U7B feeds transistor Q4 and pin 3 of the connector. Pin 3 of the connector feeds transistor Q7 of the A2 assembly which acts as a current amplifier for triac Q8. When Q8 is fired, it causes contactor K2 to energize. This applies primary voltage to the Plate and screen supply transformer primaries through the regulator SCR's A3Q1 and A3Q2.

Transistor Q4 on the A1A1 card is turned on which removes the mute voltage from the 310Z-2 exciter and initiates a ramp start voltage for the high voltage controller A1A4.

Timer U4 in conjunction with gate U5A provide a timed interval for the blower shutdown after the filaments have been turned off for cooling purposes. Overload circuitry is supplied for four functions, three of which are used on the 831C/D-2 transmitter. These are: (1) plate current, (2) screen current, and (3) VSWR. A small sample of voltage derived from a shunt resistor in the return leg of the PA Plate power supply is applied to pin 22 of the connector and routed to a multiturn pot R42. This voltage is used to turn Q5 on when sufficient current is flowing to constitute an overload condition. Integrated circuits U8A and U8B are utilized as high gain amplifiers to "square up" the transitions between on and off states of Q5 and provide a sharp edge on the transitions. The output of U8B goes to a low state for the duration of the overload and is fed to pin U of the connector for use in fault location and through CR6 to gate U7C. It is inverted in gate U7C and fed to NOR gate U1D which turns off the high voltage supply. When an overload occurs, gate U7C also fires SCR Q9 which illuminates a front panel fault indicator. Gate U5D is coupled to the output of U7C and is used as an inverter to develop a trigger pulse for automatic recycling when used. The PA Screen and VSWR overload circuits operate in a similar manner.

A1A2 Automatic Recycle/Overload Tally Card

Recycle Circuits:

This card is optional and serves two functions when installed. It will automatically restart the transmitter following an overload up to three times in a thirty second period and will provide a memory and fault indicator function of which overload caused an outage. The fault indicator lamps remain illuminated until cleared manually by the operator even though the transmitter returned to the air automatically.

A trigger pulse generated by the overload circuits on the A5A1 card is fed to integrated circuits U1, U3 and U6. Integrated circuits U1, and U3 are timers with different periods. Timer U1 generates a one-half second delay which is used to trigger timer U2. Timer U2 generates a short pulse which is fed to gate U5D and generates plate on command via transistor Q2. This command is applied to the A1A1 card to restart the plate circuit.

Timer U3 generates a pulse approximately thirty seconds in length which enables counter U4. When a restart pulse is generated by Timer U1, it is fed through gate U5A to the trigger input of counter U4. The output B of U4 will be high when a count of two is received or output C will go high when a count of four is received. When this occurs the inputs to inverters U5B and U5C are both high causing their outputs to go low. Gate U5B will inhibit any further attempts to increase the count in counter U4 and U5C will inhibit any further recycle attempts. When approximately thirty seconds has elapsed since the first recycle attempt, timer U3 times out and its output goes low and resets the count in counter U4 to zero which clears the gates U5B and U5C. The recycle circuit is then clear and will repeat as needed.

Overload Indicator Circuits:

The trigger pulse which activates the recycle circuits is also fed to NOR gates U6A through U6D. When both inputs to the NOR gate are low, its output is high. The high output causes the associated SCR to fire which lights the appropriate LED to indicate the source of the overload. The fault reset switch on the front panel will reset the indicators.

A1A3 Power Monitor Card

The power monitor card provides calibration facilities for the power meter and power adjustment facilities for the automatic power control system as well as operational amplifiers for the low level outputs of the forward and reflected power outputs of the directional coupler. These outputs are available to directly drive any common remote control system for remote indication of forward and reflected power.

Operational amplifier U1 operates at a fixed gain to produce an output on the order of one to five volts DC for remote use. The output is also summed with a negative DC reference voltage through R13 to produce a positive voltage at the output of U3. This voltage is coupled through R21 and CR3 to the power control amplifier transistor Q4. The output of Q4 is fed to the power control card A1A4 which develops the firing pulses to SCR's A3Q1 and A3Q2 which regulate the PA Plate and Screen

voltages. A switching circuit consisting of integrated circuit U4 and transistors Q1 and Q2 determines whether power control is automatic or manual. When Q1 is off and Q2 is on, the automatic power control is operational. When Q1 is on and Q2 is off an external power control voltage is selected. This voltage is derived from a motor driven potentiometer fed from the internal 28 volt power supply and is set up for remote control.

Transistor Q3 which is driven from the A1A1 card is turned off when plate voltage is turned on. A ramp voltage is generated through the time constant of R21 or R29 and R25, R26 and C14 which slowly brings plate voltage up from zero to normal output.

Integrated circuit U2 is a fixed gain operational amplifier connected to the reflected port of the directional coupler. Its output is available for remote indication and is also fed through switch S-1 to the VSWR overload input of the control circuit card for VSWR protection.

A1A4 Firing Circuit Card

This card supplies a pair of pulses to the power control SCR's whose firing angle is related to the zero crossings of the AC power lines. The firing angle is directly controlled by the DC input voltage applied to its input. In this manner, the output voltages of the plate and screen power supplies may be adjusted from 30% to full rated output voltage.

D. Power Supplies:

The Collins 831C/D-2 transmitters utilize the following power supplies:

1. 28 Volt DC Control
2. 5 Volt DC Logic
3. -120 Volt DC Bias
4. -28 Volt DC Control
5. PA Screen
6. PA Plate

28 Volt and 5 Volt Power Supplies

The 28 volt and 5 volt power supplies are derived from a common transformer, rectifier and filter system. It is a common fullwave bridge circuit with a capacitor input filter circuit. The 28 volt supply is regulated by zener diode A2 VR2 in conjunction with amplifier transistor Q2 and pass transistor Q1. Short circuit protection is provided by diodes CR8, CR9, CR10 and resistors R16 and R17. This supply furnishes power for all cards requiring +28 volts and for relay K1.

The +5 volt supply is obtained from the +28 volt supply through three terminal regulator U1. A backup battery power supply consisting of batteries BT1 - BT4 is provided to maintain the control logic circuitry during power outages. These batteries are of the alkaline rechargeable type and are floated on a constant current trickle charger consisting of Transistor Q3 and associated components. In the event of a power failure, the transmitter will restart automatically upon resumption of power. The transmitter will restart in the same mode which existed at the time of power failure.

-120 Volt Bias Supply

The -120 volt bias supply is a conventional one-half wave capacitor input filter with an LC filter following. Bias for the PA Tube is adjustable through "Bias Adjust" potentiometer R10. A gating diode CR3 disconnects the protective bias when drive appears on the PA tube. Operating bias is derived from grid leak action on the PA Tube. The primary line voltage for the protective bias supply is derived from the secondary of the filament regulator transformer.

-28 Volt Control Supply

The -28 volt control supply supplies the negative voltage required for the operational amplifiers on the power monitor and automatic power control card. It is a one-half wave supply fed from one side of the primary AC power line.

PA Screen Supply

The PA Screen supply consists of transformer A2T1 with an associated full wave bridge rectifier and a double section choke input filter system. It supplies approximately 500 volts DC to the PA Screen Grid. The voltage is adjustable by R1 the "Screen Adjust" rheostat. The primary power for the supply is derived from the power line through contactor K2 and SCR's A3Q1 and A3Q2. The screen voltage is approximately 460 volts for the 831C-2.

PA Plate Supply

The PA Plate Supply is a conventional full wave bridge supply with a two section LC filter. It supplies approximately 4500 volts DC to the PA Plate Circuit. The supply is fed from the same circuit as the PA Screen Supply. The entire supply is fed from the SCR system which is used to adjust the power supply output and, hence power output of the transmitter. The PA plate supply is approximately 3000 volts DC for the 831C-2.

E. Control and Metering

Front panel controls are provided for the following functions:

<u>Designation</u>	<u>Function</u>
Filament On	Turns on blower and filaments
Filament Off	Turns off filaments and blower following time delay
Plate On	Turns on plate and screen supplies following plate time delay
Plate Off	Turns off plate and screen supplies
Fault Reset	Resets overload indicators
Meter	Selects function for multimeter indication
Tune	Activates PA Plate Tuning motor
Load	Activates PA Loading adjustment motor
Remote/Local	Selects Local or Remote Control
Manual/Automatic	Selects manual or automatic power control
REF/FWD	Selects reflected or forward power indication
Raise/Lower	Adjusts power output in manual power control mode
Filament	Adjusts PA Filament voltage

Designation

Function

Low Voltage

Circuit breaker protects all low voltage circuits

High Voltage

Circuit Breaker protects PA Plate Supply

FUSES:

Control

Fuse protects control supply

Bias

Fuse protects bias supply

Blower

Fuse protects blower

Screen

Fuse protects screen supply

Controls on 310Z-2 Exciter:

Meter

Selects functions to be metered on multimeter

Mode

Selects left or right line for monaural or stereo operation

Power Adjust

Adjusts drive level to PA

Power Switch

Turns exciter on or off

METERING:

Multimeter

Reads following Parameters:

5Vps

Reads output voltage of 5 volt power supply

28 Vps

Reads output voltage of 28 volt power supply

FIL

Reads PA filament voltage

Bias

Reads PA operating bias voltage

Grid Current

Reads PA Grid Current

Scrn Voltage

Reads PA Screen Voltage

Scrn Current

Reads PA Screen Current

Plate Voltage

Reads PA Plate Voltage

Plate Current

Reads PA Plate Current

Power

Reads percentage of normal output power

III. ADJUSTMENT PROCEDURE

The Collins 831C/D-2 transmitters are tuned and tested on the customer's frequency. The only adjustments required should be a touch-up of PA Plate Tuning and Loading.

Perform the following steps:

- A. Turn on both circuit breakers.
- B. Press "Fil Off" Switch.
- C. Press "Fil On" Switch.
- D. Wait thirty seconds and check "Alarm" indicator on 310Z-2 modulator. It should be extinguished.
- E. Set Power Control to manual.
- F. Press "Plate On" switch.
- G. Observe forward and reflected power. Forward power should be near 100%. If it is not, refer to the factory test data sheet supplied with the transmitter and check all meter readings.
- H. Set test meter switch to "Grid Current" and adjust "Grid Tuning" control for a peak.
- I. Operate "Plate Tuning" Switch to obtain a dip in plate current.
- J. Operate "Plate Loading" switch to obtain maximum power output on the forward power meter. The "Plate Loading" and "Plate Tuning" controls will interact to a certain degree. The two controls should be adjusted alternately for highest power output with lowest input (best efficiency).
- K. Set the power output to 100% by adjustment of the "Power Output" switch on the control panel.
- L. Set the power control switch to "Automatic" and adjust R13 on the power monitor card A1A3 for 100% on the forward power meter.

IV. TYPICAL METER READINGS (831D-2 2.5 kW)

<u>METER</u>	<u>500 W</u>	<u>1000 W</u>	<u>2000 W</u>	<u>2500 W</u>
5V PS (Volts)	5	5	5	5
28V PS (Volts)	28	28	28	28
Fil (Volts)	4.8	4.8	4.8	4.8
Bias (Volts)	105	100	100	98
Grid Current (MA)	11	10	9.5	9.3
Screen Voltage (Volts)	270	350	465	525
Screen Current (MA)		65	78	90
Plate Voltage	2250	3200	4500	4750
Plate Current (MA)	340	480	680	790
*Forward Power (%)	100%	100%	100%	100%

IV. TYPICAL METER READINGS (831C-2 1.25 kW)

<u>METER</u>	<u>250 W</u>	<u>500 W</u>	<u>750 W</u>	<u>1000 W</u>	<u>1250 W</u>
5V PS (Volts)	5.1	5.1	5.1	5.1	5.1
28V PS (Volts)	30	30	30	30	30
Fil (Volts)	4.95	5.0	5.0	5.0	5.0
Bias (Volts)	135	131	128	125	121
Grid Current (MA)	7.0	6.5	5.8	5.2	4.5
Screen Voltage (Volts)	210	270	310	350	390
Screen Current (MA)	25	37	47	57	66
Plate Voltage	1450	1900	2280	2550	2880
Plate Current (MA)	290	390	470	550	630
*Forward Power (%)	100%	100%	100%	100%	100%

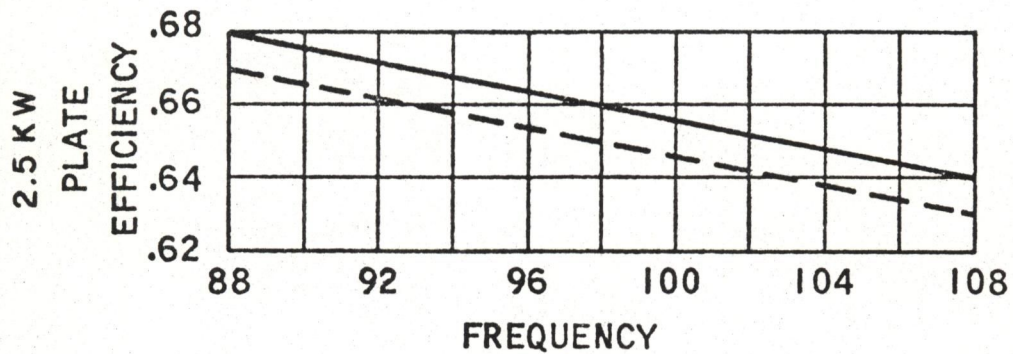

NOTE:

DASHED LINE REPRESENTS MINIMUM
ALLOWABLE EFFICIENCY

PLATE EFFICIENCY
VERSUS
FREQUENCY

FOR 831D-2 2.5KW FM BROADCAST TRANSMITTER

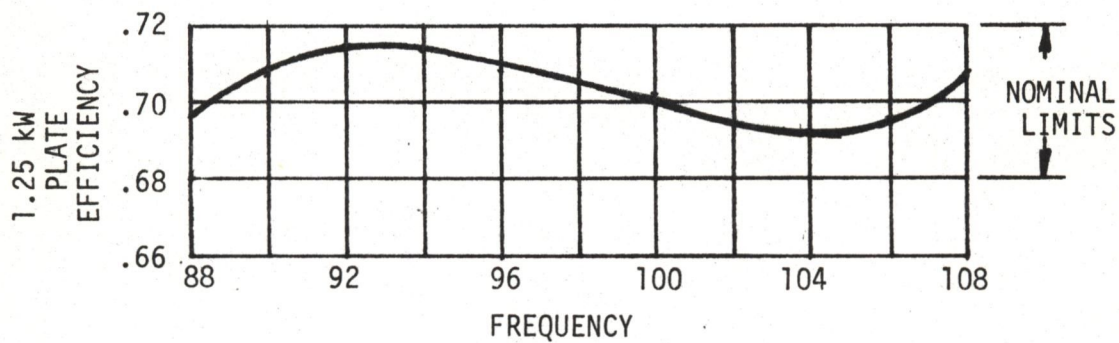
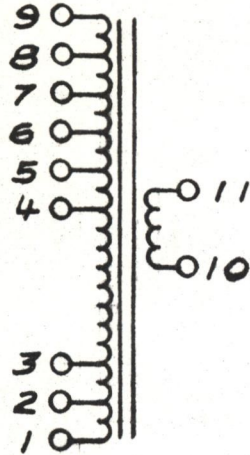

PLATE EFFICIENCY
 VERSUS
 FREQUENCY

FOR 831C-2 1.25 kW FM BROADCAST TRANSMITTER

V. TRANSFORMER CONNECTIONS

**PLATE
T2**



**28 VOLT
A2T2**

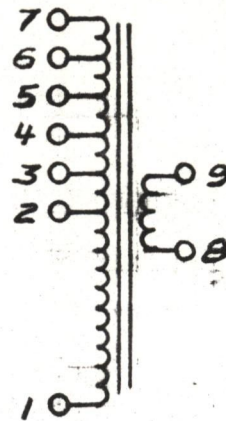

LINE VOLTAGE PRIMARY TERMINAL
 CONNECTION USED

200	3-4
210	3-5
220	3-6
230	3-7
240	3-8
250	3-9

LINE VOLTAGE PRIMARY TERMINAL
 CONNECTION USED

200	1-2
210	1-3
220	1-4
230	1-5
240	1-6
250	1-7

**SCREEN
A2T1**

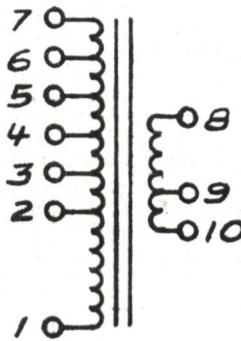

NOTE:

FOR OPERATION LESS THAN
1400 WATTS OUTPUT USE
TERMINALS 8-9 OTHERWISE
USE 8-10

LINE VOLTAGE PRIMARY TERMINAL
 CONNECTION USED

200	1-2
210	1-3
220	1-4
230	1-5
240	1-6
250	1-7

REVISIONS	DATE	APPROVED

LTR	DESCRIPTION

NOTES:
 1. DIMENSIONS IN PARENTHESIS DENOTE INCHES. OTHER DIMENSIONS ARE IN MILLIMETERS.

310Z-2 FM EXCITER

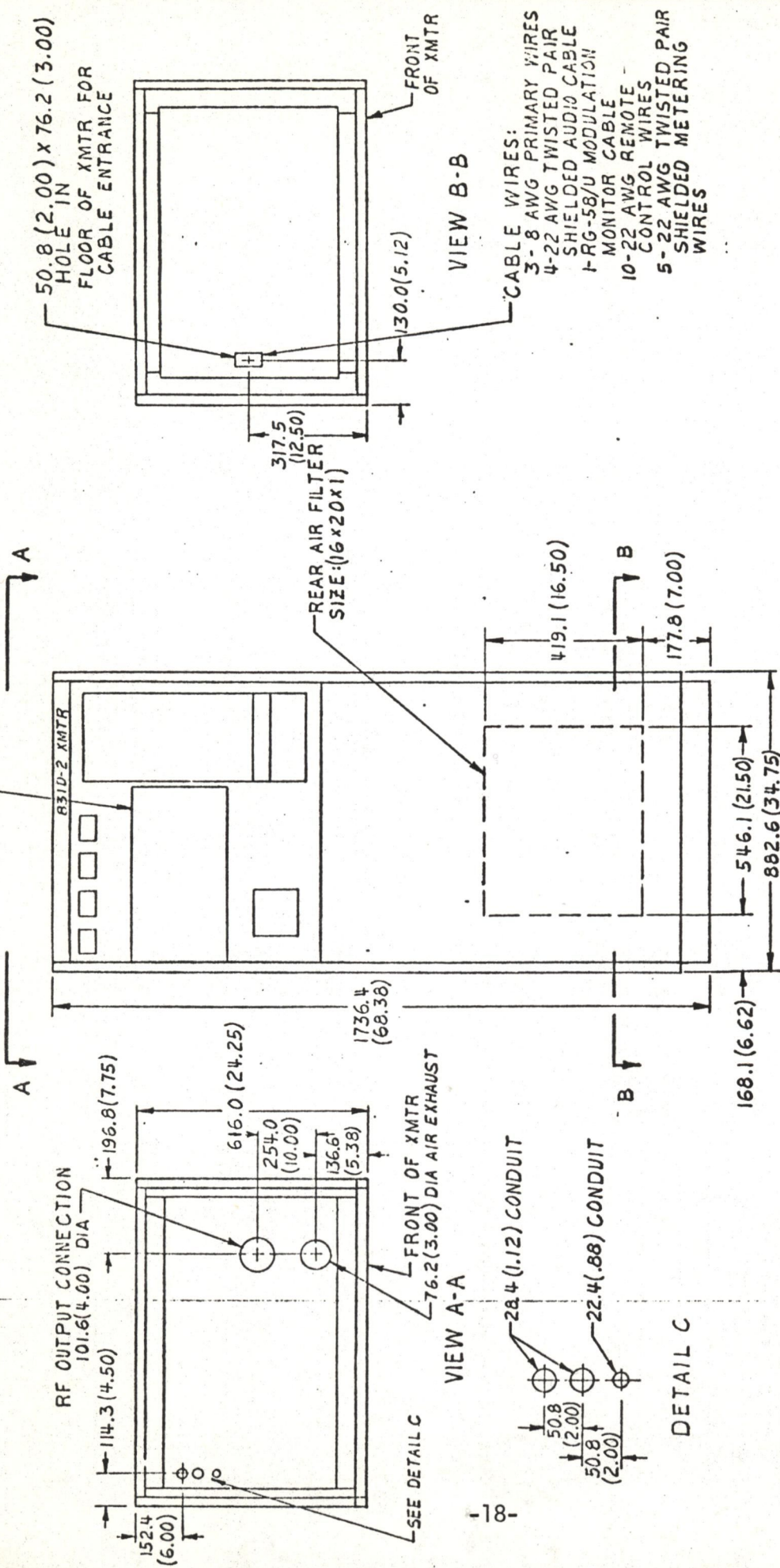

RF OUTPUT CONNECTOR
 1-5/8" EIA FLANGE RECESSED
 133.4 (5.25)" BELOW TOP

- CABLE WIRES:
- 3-8 AWG PRIMARY WIRES
 - 4-22 AWG TWISTED PAIR SHIELDED AUDIO CABLE
 - 1-RG-58/U MODULATION MONITOR CABLE
 - 10-22 AWG REMOTE CONTROL WIRES
 - 5-22 AWG TWISTED PAIR SHIELDED METERING WIRES

QTY	ITEM NO.	PART OR IDENTIFYING NO.	NAME	DESCRIPTION	UM	MIN	PREP

PARTS LIST

CONTRACT NO. PREP *Chait City* 2/2/70
 CHK
 APVD

UNLESS OTHERWISE SPECIFIED
 DIMENSIONS ARE IN INCHES; TOL ON DEC DIM.: .XX = ±.02, .XXX = ±.008
 HOLE DIAMETERS:
 UNDER .251 DIA = +.005-.005
 .251 TO .500 DIA = +.006-.005
 OVER .500 DIA = +.008-.005
 ANGLES: ±1.0°
 ECCENTRICITY BETWEEN DIA ON AN AXIS NOT TO EXCEED .010 DIA
 PART SHALL COMPLY TO 390-5400-.001

MATERIAL
 FINISH

COLLINS RADIO COMPANY
 DALLAS, TEX. NIGHT REACH, CALIF. CEDAR RAPIDS, IA
 OUTLINE & INSTALLATION OF
 831C/D-2
 SIZE CODE IDENT DWG NO. C 13499 632-0075-001
 SCALE SHEET

www.SteamPoweredRadio.com

PARTS LISTINGS

831C/D-2

SYMBOL	DESCRIPTION	COLLINS PART NUMBER
ASSEMBLY: 831C-2/D-2 XMTR ASSY CPN 632-0034-001		
A1	ASSY. FRONT PANEL	632-0030-001
A1A1	ASSY. CONTROL CIRCUITS CARD	632-0007-001
A1A2	ASSY. OVERLOAD TALLY RECYCLE (OPTIONAL)	632-0013-001
A1A3	ASSY. POWER MONITOR CARD	632-0010-001
A1A4	ASSY. POWER CONTROL	270-0313-010
A1A5	ASSY. CARD CAGE	632-0031-001
A1A6	ASSY. TUBE COMPARTMENT	
A2	ASSY. CONTROL CIRCUITS	632-0021-001
A3	ASSY. HIGH VOLTAGE PANEL	632-0033-001
A3A1	ASSY. BOARD	632-0004-001
A3A2	ASSY. COMPONENT	632-0049-001
A4	ASSY. REMOTE CONTROL (OPTIONAL)	632-0071-001
A5	CARD, EXTENDER	632-0062-001
B1	BLOWER	009-1858-010
DC1	COUPLER	277-0445-010
J4	CONNECTOR	357-9248-010
P1	CONNECTOR	366-8060-000
P2	CONNECTOR	357-9292-000
R1	RESISTOR	746-6827-000
R2	RESISTOR	746-6827-000
R3	RESISTOR	746-6827-000
T1	TRANSFORMER	662-0292-050

parts list

SYMBOL	DESCRIPTION	COLLINS PART NUMBER
THE FOLLOWING COMPONENTS ARE USED ONLY IN THE 831C-2 TRANSMITTER:		
C1	CAPACITOR 4.0 μ F 4 kV	930-0705-000
C2	CAPACITOR 4.0 μ F 4 kV	930-0705-000
L1	CHOKE 10 Hy	668-0022-000
L2	CHOKE 10 Hy	668-0022-000
T2	TRANSFORMER HIGH VOLTAGE	662-0368-020
THE FOLLOWING COMPONENTS ARE USED ONLY IN THE 831D-2 TRANSMITTER:		
C1	CAPACITOR 8 μ F	930-0781-020
C2	CAPACITOR 8 μ F	930-0781-020
L1	CHOKE 10 Hy	668-0161-010
L2	CHOKE 10 Hy	668-0161-010
T2	TRANSFORMER HIGH VOLTAGE	662-0368-010

SYMBOL	DESCRIPTION	COLLINS PART NUMBER
ASSEMBLY: A1 FRONT PANEL, CPN 632-0030-001		
A1A1	CIRCUIT BOARD CONTROL	632-0007-001
A1A2	CIRCUIT BOARD (OPT.) RECYCLE TALLY	632-0013-001
A1A3	CIRCUIT BOARD POWER MONITOR	632-0010-001
A1A4	CIRCUIT BOARD POWER CONTROL	270-0313-010
A1A5	ASSEMBLY CARD CAGE	632-0031-001
A1A6	ASSEMBLY POWER AMPLIFIER	632-0039-001
C1	CAPACITOR 100 pf	912-2816-000
C2	CAPACITOR 100 pf	912-2816-000
C3	CAPACITOR 100 pf	912-2816-000
C4	CAPACITOR 100 pf	912-2816-000
CB1	CIRCUIT BREAKER 5 Amp	260-1964-000
CB2	CIRCUIT BREAKER 30 Amp	260-4052-010
F1	FUSE .5 Amp	264-0293-000
F2	FUSE .5 Amp	264-0293-000
F3	FUSE 2 Amp	264-0297-000
F4	FUSE 1 Amp	264-0295-000
M1	METER	458-0783-050
M2	METER	458-0783-060
M3	METER	458-0783-190
M4	METER	458-0821-060

SYMBOL	DESCRIPTION	COLLINS PART NUMBER
R1	RESISTOR 15 Ohm 100 W	735-5201-020
R2	RESISTOR 1.74 K	705-6758-000
S1	SWITCH	266-7509-020
S2	SWITCH	266-7509-020
S3	SWITCH	266-7509-020
S4	SWITCH	266-7509-020
S5	SWITCH	266-7509-020
S6	SWITCH	259-2692-010
S7	SWITCH	375-1019-190
S8	SWITCH	375-1019-190
S9	SWITCH	375-1019-180
S10	SWITCH	375-1019-190
S11	SWITCH	375-1019-180
S12	SWITCH	375-1019-190
XF1	FUSEHOLDER	265-1241-090
XF2	FUSEHOLDER	265-1241-090
XF3	FUSEHOLDER	265-1241-090
XF4	FUSEHOLDER	265-1241-090

SYMBOL	DESCRIPTION	COLLINS PART NUMBER
ASSEMBLY: A1A1 CONTROL CIRCUITS CPN 632-0007-001		
C1	CAPACITOR 1.0 μ F 25 V	913-3810-000
C2	CAPACITOR 1.0 μ F 25 V	913-3810-000
C3	CAPACITOR 1.0 μ F 25 V	913-3810-000
C4	CAPACITOR 1.0 μ F 25 V	913-3810-000
C5	CAPACITOR 1.0 μ F 25 V	913-3810-000
C6	CAPACITOR 1.0 μ F 25 V	913-3810-000
C7	CAPACITOR 1.0 μ F 25 V	913-3810-000
C8	CAPACITOR 1.0 μ F 25 V	913-3810-000
C9	CAPACITOR 1.0 μ F 25 V	913-3810-000
C10	CAPACITOR 1.0 μ F 25 V	913-3810-000
C11	CAPACITOR 1.0 μ F 25 V	913-3810-000
C12	CAPACITOR 1.0 μ F 25 V	913-3810-000
C13	CAPACITOR 0.01 μ F	913-3279-110
C14	CAPACITOR 1.0 μ F 25 V	913-3810-000
C15	CAPACITOR 1.0 μ F 20 V	184-9086-470
C16	CAPACITOR 1.0 μ F 25 V	913-3810-000
C17	CAPACITOR 1.0 μ F 25 V	913-3810-000
C18	CAPACITOR 0.01 μ F	913-3279-110
C19	CAPACITOR 1.0 μ F 25 V	913-3810-000
C20	CAPACITOR 22 μ F 15 V	184-9086-320
C21	CAPACITOR 1.0 μ F 25 V	913-3810-000
C22	CAPACITOR 1.0 μ F 25 V	913-3810-000
C23	CAPACITOR 1.0 μ F 25 V	913-3810-000

parts list

SYMBOL	DESCRIPTION	COLLINS PART NUMBER
C24	CAPACITOR 1.0 μ F 25 V	913-3810-000
C25	CAPACITOR 1.0 μ F 25 V	913-3810-000
C26	CAPACITOR 1.0 μ F 25 V	913-3810-000
C27	CAPACITOR 1.0 μ F 25 V	913-3810-000
C28	CAPACITOR 1.0 μ F 25 V	913-3810-000
C29	CAPACITOR 1.0 μ F 25 V	913-3810-000
C30	CAPACITOR 1.0 μ F 25 V	913-3810-000
C31	CAPACITOR 1.0 μ F 25 V	913-3810-000
C32	CAPACITOR 250 μ F 12 V	183-1190-000
C33	CAPACITOR 1.0 μ F 25 V	913-3810-000
C34	CAPACITOR 1.0 μ F 25 V	913-3810-000
CR1	DIODE 1N914	353-2906-000
CR2	DIODE 1N914	353-2906-000
CR3	DIODE 1N914	353-2906-000
CR4	DIODE 1N914	353-2906-000
CR5	DIODE 1N914	353-2906-000
CR6	DIODE 1N914	353-2906-000
CR7	DIODE 1N914	353-2906-000
CR8	DIODE 1N914	353-2906-000
CR9	DIODE 1N914	353-2906-000
CR10	DIODE 1N914	353-2906-000
CR11	DIODE 1N914	353-2906-000
CR12	DIODE 1N914	353-2906-000
CR13	DIODE 1N914	353-2906-000

SYMBOL	DESCRIPTION		COLLINS PART NUMBER
ASSEMBLY: A1A1 CONTROL CIRCUITS CPN 632-0007-001			
Q1	TRANSISTOR	2N3053	352-0613-010
Q2	TRANSISTOR	2N3053	352-0613-010
Q3	TRANSISTOR	2N3053	352-0613-010
Q4	TRANSISTOR	2N3053	352-0613-010
Q5	TRANSISTOR	2N2222A	352-0661-023
Q6	TRANSISTOR	2N2222A	352-0661-023
Q7	TRANSISTOR	2N2222A	352-0661-023
Q8	TRANSISTOR	2N2222A	352-0661-023
Q9	SCR	C6F	353-6468-010
R1	RESISTOR	1.5 K 1/2 W	745-1359-000
R2	RESISTOR	330 Ohm 1/4 W	745-0731-000
R3	RESISTOR	1.5 K 1/2 W	745-1359-000
R4	RESISTOR	330 Ohm 1/4 W	745-0731-000
R5	RESISTOR	1.5 K 1/2 W	745-1359-000
R6	RESISTOR	330 Ohm 1/4 W	745-0731-000
R7	RESISTOR	1.5 K 1/2 W	745-1359-000
R8	RESISTOR	330 Ohm 1/4 W	745-0731-000
R9	RESISTOR	100 Ohm 1/4 W	745-0713-000
R10	RESISTOR	100 Ohm 1/4 W	745-0713-000
R11	RESISTOR	100 Ohm 1/4 W	745-0713-000
R12	RESISTOR	100 Ohm 1/4 W	745-0713-000
R13	RESISTOR	1.5 K 2 W	745-5659-000

parts list

SYMBOL	DESCRIPTION	COLLINS PART NUMBER
R14	RESISTOR 330 Ohm 1/4 W	745-0731-000
R15	RESISTOR 4.7 K 1/4 W	745-0733-000
R16	RESISTOR 2.2 M 1/4 W	745-0869-000
R17	RESISTOR 2.2 K 1/4 W	745-0761-000
R18	RESISTOR 27 Ohm 1/2 W	745-1286-000
R19	RESISTOR 2.2 K 1/2 W	745-0761-000
R20	RESISTOR 470 Ohm 1/4 W	745-0737-000
R21	RESISTOR 2.2 K 1/4 W	745-0761-000
R22	RESISTOR 470 Ohm 1/4 W	745-0737-000
R23	RESISTOR 2.2 K 1/4 W	745-0761-000
R24	RESISTOR 27 Ohm 1/2 W	745-1286-000
R25	RESISTOR 1.5 K 2 W	745-5659-000
R26	RESISTOR 330 Ohm 1/4 W	745-0731-000
R27	RESISTOR 100 Ohm 1/4 W	745-0713-000
R28	RESISTOR 4.7 K 1/4 W	745-0773-000
R29	RESISTOR 1 M VARIABLE	380-3761-130
R30	RESISTOR 1 M 1/4 W	745-0857-000
R31	RESISTOR 4.7 K 1/4 W	745-0773-000
R32	RESISTOR 2.2 K 1/4 W	745-0761-000
R33	RESISTOR 2.2 K 1/4 W	745-0761-000
R34	RESISTOR 470 Ohm 1/4 W	745-0737-000
R35	RESISTOR 2.2 K 1/4 W	745-0761-000
R36	RESISTOR 1 K 2 W	745-5652-000
R37	RESISTOR 27 Ohm 1/2 W	745-1286-000
R38	RESISTOR 2.2 K 1/4 W	745-0761-000

SYMBOL	DESCRIPTION	COLLINS PART NUMBER
ASSEMBLY: A1A1 CONTROL CIRCUITS CPN 632-0007-001		
R39	RESISTOR 2.2 K 1/4 W	745-0761-000
R40	RESISTOR 1 K 1/4 W	745-0749-000
R41	RESISTOR 220 Ohm 1/4 W	745-0725-000
R42	RESISTOR 500 Ohm VARIABLE	381-1721-030
R43	RESISTOR 470 Ohm 1/4 W	745-0737-000
R44	RESISTOR 2.2 K 1/4 W	745-0761-000
R45	RESISTOR 1 K 1/4 W	745-0749-000
R46	RESISTOR 220 Ohm 1/4 W	745-0725-000
R47	RESISTOR 500 Ohm VARIABLE	381-1721-030
R48	RESISTOR 470 Ohm 1/4 W	745-0737-000
R49	RESISTOR 2.2 K 1/4 W	745-0761-000
R50	RESISTOR 1 K 1/4 W	745-0749-000
R51	RESISTOR 220 Ohm 1/4 W	745-0725-000
R52	RESISTOR 500 Ohm VARIABLE	381-1721-030
R53	RESISTOR 470 Ohm 1/4 W	745-0737-000
R54	RESISTOR 2.2 K 1/4 W	745-0761-000
R55	RESISTOR 2.2 K 1/4 W	745-0761-000
R56	RESISTOR 5 K VARIABLE	381-1721-060
R57	RESISTOR 100 Ohm	745-0713-000
R58	RESISTOR 4.7 K 1/4 W	745-0773-000
R59	RESISTOR 100 Ohm	745-0713-000
R60	RESISTOR 470 Ohm 1/4 W	745-0737-000
R61	RESISTOR 27 Ohm 1/2 W	745-1286-000

SYMBOL	DESCRIPTION	COLLINS PART NUMBER
R62	RESISTOR 27 Ohm 1/2 W	745-1286-000
R63	RESISTOR 4.7 K 1/4 W	745-0773-000
R64	RESISTOR 4.7 K 1/4 W	745-0773-000
R65	RESISTOR 470 Ohm 1/4 W	745-0737-000
S1	SWITCH	266-5321-980
U1	INT. CIRCUIT SN7402N	351-7628-010
U2	INT. CIRCUIT SN7476N	351-7702-010
U3	INT. CIRCUIT SN7400N	351-7629-010
U4	INT. CIRCUIT NE555V	351-1137-020
U5	INT. CIRCUIT SN7402N	351-7628-010
U6	INT. CIRCUIT NE555V	351-1137-020
U7	INT. CIRCUIT SN7410N	351-7635-010
U8	INT. CIRCUIT SN7404N	351-7630-010
U9	INT. CIRCUIT SN7404N	351-7630-010
VR1	ZENER DIODE 1N4728A	353-6481-010
VR2	ZENER DIODE 1N4728A	353-6481-010
VR3	ZENER DIODE 1N4728A	353-6481-010
VR4	ZENER DIODE 1N4728A	353-6481-010
VR5	ZENER DIODE 1N4728A	353-6481-010
VR6	ZENER DIODE 1N4728A	353-6481-010

SYMBOL	DESCRIPTION	COLLINS PART NUMBER
ASSEMBLY: A1A1 CONTROL CIRCUITS CPN 632-0007-001		
XU1	SOCKET	220-0049-010
XU2	SOCKET	220-0049-020
XU3	SOCKET	220-0049-010
XU4	SOCKET	220-0001-060
XU5	SOCKET	220-0049-010
XU6	SOCKET	220-0001-060
XU7	SOCKET	220-0049-010
XU8	SOCKET	220-0049-010
XU9	SOCKET	220-0049-010

SYMBOL	DESCRIPTION	COLLINS PART NUMBER
ASSEMBLY: A1A2 OVLD TALLY/RECYCLE (OPTIONAL) CPN 632-0013-001		
C1	CAPACITOR 250 μ F 12 V	183-1190-000
C2	CAPACITOR 0.01 μ F 50 V	913-3279-110
C3	CAPACITOR 1.0 μ F 25 V	913-3810-000
C4	CAPACITOR 10 μ F 20 V	184-9086-470
C5	CAPACITOR 0.01 μ F 50 V	913-3279-110
C6	CAPACITOR 1.0 μ F 25 V	913-3810-000
C7	CAPACITOR 1.0 μ F 25 V	913-3810-000
C8	CAPACITOR 1.0 μ F 25 V	913-3810-000
C9	CAPACITOR 0.01 μ F 50 V	913-3279-110
C10	CAPACITOR 1.0 μ F 25 V	913-3810-000
C11	CAPACITOR 1.0 μ F 25 V	913-3810-000
C12	CAPACITOR 1.0 μ F 25 V	913-3810-000
C13	CAPACITOR 1.0 μ F 25 V	913-3810-000
C14	CAPACITOR 1.0 μ F 25 V	913-3810-000
C15	CAPACITOR .01 μ F	913-3680-000
CR1	DIODE 1N914	353-2906-000
CR2	DIODE LIGHT EMITTING	353-3725-030
CR3	DIODE LIGHT EMITTING	353-3725-030
CR4	DIODE LIGHT EMITTING	353-3725-030
CR5	DIODE LIGHT EMITTING	353-3725-030
CR6	DIODE 1N914	353-2906-000
CR7	DIODE 1N914	353-2906-000
CR8	DIODE 1N914	353-2906-000

SYMBOL	DESCRIPTION	COLLINS PART NUMBER
CR9	DIODE 1N914	353-2906-000
L1	CHOKE 100 H	240-2715-370
Q1	TRANSISTOR 2N2222A	352-0661-023
Q2	TRANSISTOR 2N2222A	352-0661-023
Q3	SCR C6F	353-6468-010
Q4	SCR C6F	353-6468-010
Q5	SCR C6F	353-6468-010
Q6	SCR C6F	353-6468-010
R1	RESISTOR 2.2M 1/4 W	745-0869-000
R2	RESISTOR 1 K 1/4 W	745-0749-000
R3	RESISTOR 1 M 1/4 W	745-0857-000
R4	RESISTOR 4.7 K 1/4 W	745-0773-000
R5	RESISTOR 470 K 1/4 W	745-0845-000
R6	RESISTOR 2.2 K 1/4 W	745-0761-000
R7	RESISTOR 2.2 K 1/4 W	745-0761-000
R8	RESISTOR 470 Ohm 1/4 W	745-0737-000
R9	RESISTOR 470 Ohm 1/4 W	745-0737-000
R10	RESISTOR 470 Ohm 1/4 W	745-0737-000
R11	RESISTOR 470 Ohm 1/4 W	745-0737-000
R12	RESISTOR 470 Ohm 1/4 W	745-0737-000
R13	RESISTOR 470 Ohm 1/4 W	745-0737-000
R14	RESISTOR 470 Ohm 1/4 W	745-0737-000
R15	RESISTOR 470 Ohm 1/4 W	745-0737-000
R16	RESISTOR 1.2 K 2 W	745-5656-000

SYMBOL	DESCRIPTION	COLLINS PART NUMBER
ASSEMBLY: A1A2 OVLD TALLY/RECYCLE (OPTIONAL) CPN 632-0013-001		
R17	RESISTOR 1.2 K 2 W	745-5656-000
R18	RESISTOR 1.2 K 2 W	745-5656-000
R19	RESISTOR 1.2 K 2 W	745-5656-000
U1	INT. CIRCUIT NE555V	351-1137-020
U2	INT. CIRCUIT NE555V	351-1137-020
U3	INT. CIRCUIT NE555V	351-1137-020
U4	INT. CIRCUIT SN7492N	351-7771-010
U5	INT. CIRCUIT SN7400N	351-7629-010
U6	INT. CIRCUIT SN7402N	351-7628-010
XU1	SOCKET	220-0001-060
XU2	SOCKET	220-0001-060
XU3	SOCKET	220-0001-060
XU4	SOCKET	220-0049-010
XU5	SOCKET	220-0049-010
XU6	SOCKET	220-0049-010

SYMBOL	DESCRIPTION	COLLINS PART NUMBER
ASSEMBLY: A1A3 POWER MONITOR CPN 632-0010-001		
C1	CAPACITOR 1.0 μ F 25 V	913-3810-000
C2	CAPACITOR 1.0 μ F 25 V	913-3810-000
C3	CAPACITOR 1.0 μ F 25 V	913-3810-000
C4	CAPACITOR 1.0 μ F 25 V	913-3810-000
C5	CAPACITOR 1.0 μ F 25 V	913-3810-000
C6	CAPACITOR 1.0 μ F 25 V	913-3810-000
C7	CAPACITOR 1.0 μ F 25 V	913-3810-000
C8	CAPACITOR 1.0 μ F 25 V	913-3810-000
C9	CAPACITOR 1.0 μ F 25 V	913-3810-000
C10	CAPACITOR 1.0 μ F 25 V	913-3810-000
C11	CAPACITOR 10 μ F 20 V	184-9086-470
C12	CAPACITOR 1.0 μ F 25 V	913-3810-000
C13	CAPACITOR 1.0 μ F 25 V	913-3810-000
C14	CAPACITOR 150 μ F 30 V	184-8673-000
C15	CAPACITOR 1.0 μ F 25 V	913-3810-000
C16	CAPACITOR 1.0 μ F 25 V	913-3810-000
C17	CAPACITOR 1.0 μ F 25 V	913-3810-000
C18	CAPACITOR 1.0 μ F 25 V	913-3810-000
CR1	DIODE 1N914	353-2906-000
CR2	DIODE 1N914	353-2906-000
CR3	DIODE 1N914	353-2906-000
CR4	DIODE 1N914	353-2906-000
CR5	DIODE 1N914	353-2906-000

parts list

SYMBOL	DESCRIPTION	COLLINS PART NUMBER
CR6	DIODE 1N4003	353-6442-030
R1	RESISTOR 20 K VARIABLE	381-1721-150
R2	RESISTOR 10 K 1/8 W	705-1454-630
R3	RESISTOR 10.5 K 1/8 W	705-1470-870
R4	RESISTOR 20 K VARIABLE	381-1721-150
R5	RESISTOR 10 K 1/8 W	705-1454-630
R6	RESISTOR 10.5 K 1/8 W	705-1470-870
R7	RESISTOR 68.1 K 1/8 W	705-1454-830
R8	RESISTOR 1 K 1/4 W	705-0749-000
R9	RESISTOR 78.7 K	705-1087-000
R10	RESISTOR 1 K 1/4 W	705-0749-000
R11	RESISTOR 10 K 1/8 W	705-1454-630
R12	RESISTOR 10 K 1/8 W	705-1454-630
R13	RESISTOR 10 K VARIABLE	381-1721-130
R14	RESISTOR 4.64 K 1/8 W	705-1454-550
R15	RESISTOR 220 Ohm 1/4 W	745-0725-000
R16	RESISTOR 1.5 K 1/2 W	745-1359-000
R17	RESISTOR 1.5 K 1/2 W	745-1359-000
R18	RESISTOR 220 Ohm 1/4 W	745-0725-000
R19	RESISTOR 5.11 K	705-6630-000
R20	RESISTOR 825 K 1/8 W	705-9736-000
R21	RESISTOR 1 K 1/2 W	745-1352-000
R22	RESISTOR 220 Ohm 2 W	745-5624-000
R23	RESISTOR 220 Ohm 2 W	745-5624-000

SYMBOL	DESCRIPTION	COLLINS PART NUMBER
ASSEMBLY: A1A3 POWER MONITOR, CPN 632-0010-001		
R24	RESISTOR 2.2K 1/4 W	745-0761-000
R25	RESISTOR 1 K 1/4 W	745-0749-000
R26	RESISTOR 68 K 1/4 W	745-0815-000
R27	RESISTOR 100 Ohm 1/2 W	745-1310-000
R28	RESISTOR 2.2 K 1/4 W	745-0761-000
R29	RESISTOR 1 K 1/2 W	745-1352-000
R30	RESISTOR 1 K 1/4 W	745-0749-000
R31	RESISTOR 4.7 K 1/4 W	745-0773-000
R32	RESISTOR 2.2 K 1/4 W	745-0761-000
R33	RESISTOR 10 K 1/4 W	745-0785-000
R34	RESISTOR 1 K 1/2 W	745-1352-000
R35	RESISTOR 1 K 1/2 W	745-1352-000
R36	RESISTOR 1 K 1/2 W	745-1352-000
R37	RESISTOR 10 K VARIABLE	381-1721-120
R38	RESISTOR 10 K VARIABLE	381-1721-120
R39	RESISTOR 4.7 K 1/2 W	745-1380-000
R40	RESISTOR 417 K 1/2 W	745-1380-000
R41	RESISTOR 3.32 K 1/8 W	705-1470-750
R42	RESISTOR 100 Ohm 1/4 W	745-0713-000
R43	RESISTOR 100 Ohm 1/4 W	745-0713-000

parts list

SYMBOL	DESCRIPTION	COLLINS PART NUMBER
S1	SWITCH SPDT	266-5321-980
TP1	TEST POINT	360-0434-030
TP2	TEST POINT	360-0434-040
TP3	TEST POINT	360-0434-070
TP4	TEST POINT	360-0434-050
TP5	TEST POINT	360-04340-010
Q1	TRANSISTOR 2N2222A	352-0661-023
Q2	TRANSISTOR 2N2222A	352-0661-023
Q3	TRANSISTOR 2N3053	352-0613-010
Q4	TRANSISTOR 2N2222A	352-0661-023
U1	INT. CIRCUIT μ A 741	351-1029-020
U2	INT. CIRCUIT μ A 741	351-1029-020
U3	INT. CIRCUIT μ A 741	351-1029-020
U4	INT. CIRCUIT SN7400N	351-7629-010
VR1	ZENER DIODE 1N4744A	353-6481-330
VR2	ZENER DIODE 1N4744A	353-6481-330
XU4	SOCKET	220-0049-010

SYMBOL	DESCRIPTION	COLLINS PART NUMBER
ASSEMBLY: A1A5 CARD CAGE ASSY CPN 632-0031-001		
B1	MOTOR	230-0641-010
C1	CAPACITOR 0.33 μ F 600 V	951-1066-000
C2	CAPACITOR 0.1 μ F 25 V	913-3806-000
C3	CAPACITOR 0.1 μ F 25 V	913-3806-000
C4	CAPACITOR 0.1 μ F 25 V	913-3806-000
J1	CONNECTOR	372-7514-030
J2	CONNECTOR	372-7514-030
J3	CONNECTOR	372-7514-030
J4	CONNECTOR	372-5906-010
R2	RESISTOR 5K VARIABLE	376-2487-000
S1	SWITCH	266-8000-000
T1	TRANSFORMER	270-0313-020

SYMBOL	DESCRIPTION	COLLINS PART NUMBER
ASSEMBLY: A1A6 TUBE COMPARTMENT, CPN 632-0039-001		
B1	MOTOR	230-0581-010
B2	MOTOR	230-0581-010
C1	CAPACITOR 1000 pf	913-4238-010
C2	CAPACITOR 1000 pf	913-1292-000
C3	CAPACITOR 565 pf	914-2721-000
C4	CAPACITOR 3.0 - 18.7 pf	922-0033-000
C5	CAPACITOR 3.0 - 18.7 pf	922-0033-000
C6	CAPACITOR 1000 pf	913-0101-000
C7	CAPACITOR 1000 pf	913-0101-000
C8	CAPACITOR 1000 pf	913-0101-000
C9	CAPACITOR MECHANICAL PART	
C10	CAPACITOR MECHANICAL PART	
C11	CAPACITOR BLOCKER	788-8249-001
C12	CAPACITOR 565 pf	914-2721-000
C13	CAPACITOR 564 pf	914-2721-000
C14	CAPACITOR 565 pf	914-2721-000
C15	CAPACITOR 565 pf	914-2721-000
C16	CAPACITOR 565 pf	914-2721-000
C17	CAPACITOR 565 pf	914-2721-000
C18	CAPACITOR 565 pf	914-2721-000
C19	CAPACITOR 565 pf	914-2721-000
C20	CAPACITOR 565 pf	914-2721-000
C21	CAPACITOR 565 pf	914-2721-000

parts list

SYMBOL	DESCRIPTION	COLLINS PART NUMBER
C22	CAPACITOR 565 pf	914-2721-000
C23	CAPACITOR 565 pf	914-2721-000
C24	CAPACITOR .47 μ F	931-6849-000
C25	CAPACITOR .47 μ F	931-6849-000
C26	CAPACITOR 565 pf	914-2721-000
C27	CAPACITOR 20 pf	913-0838-000
FL1	FILTER	632-0068-001
J2	CONNECTOR	357-9670-000
J3	CONNECTOR	357-9670-000
L3	INDUCTOR 4.7 μ Hy	240-0178-000
L4	INDUCTOR 3.3 μ Hy	240-1574-000
L5	INDUCTOR 3.3 μ Hy	240-1574-000
L6	INDUCTOR 3.3 μ Hy	240-1574-000
L7	INDUCTOR 3.3 μ Hy	240-1574-000
L8	INDUCTOR	788-8218-001
L9	INDUCTOR MECHANICAL PART	
L10	INDUCTOR MECHANICAL PART	
P1	CONNECTOR	357-9292-000
R1	RESISTOR 120 Ohms	747-5442-000
R2	RESISTOR 12 Ohms	747-0726-000
R50	RESISTOR 50 Ohms	712-0072-000

SYMBOL	DESCRIPTION	COLLINS PART NUMBER
ASSEMBLY: A1A6 TUBE COMPARTMENT, CPN 632-0039-001		
S1	SWITCH	627-9743-005
S2	SWITCH	627-9743-001
S3	SWITCH	260-0944-000
S4	SWITCH	260-0944-000
S5	SWITCH	260-0944-000
S6	SWITCH	260-0944-000
S7	SWITCH	266-8384-090
V1	TUBE	256-0200-000
XV1	SOCKET	220-0967-010

SYMBOL	DESCRIPTION	COLLINS PART NUMBER
ASSEMBLY: A2 CONTROL CIRCUITS AND LOW VOLTAGE SUPPLIES, CPN 632-0021-001		
BT1	BATTERY	221-0080-010
BT2	BATTERY	221-0080-010
BT3	BATTERY	221-0080-010
BT4	BATTERY	221-0080-010
C1	CAPACITOR 10 μ f 1 kV	930-0038-000
C2	CAPACITOR 10 μ f 1 kV	930-0038-000
<u>C3</u>	CAPACITOR 30 μ f 200 V	183-1282-330
<u>C4</u>	CAPACITOR 30 μ f 200 V	183-1282-330
C5	CAPACITOR 100 μ f 50 V	183-1281-080
C6	CAPACITOR 3900 μ f 50 V	183-1278-370
<u>C7</u>	CAPACITOR 100 μ f 50 V	183-1281-080
<u>C8</u>	CAPACITOR 0.1 μ f 500 V	913-3234-000
<u>C9</u>	CAPACITOR 0.1 μ f 25 V	913-3806-000
<u>C10</u>	CAPACITOR 0.1 μ f 25 V	913-3806-000
<u>C11</u>	CAPACITOR 180 μ f 25 V	184-8664-000
<u>C12</u>	CAPACITOR 180 μ f 25 V	184-8664-000
<u>C13</u>	CAPACITOR 0.1 μ f 25 V	913-3806-000
<u>C14</u>	CAPACITOR 0.1 μ f 500 V	913-3234-000
<u>C15</u>	CAPACITOR 0.1 μ f 25 V	913-3806-000
<u>C16</u>	CAPACITOR 0.1 μ f 25 V	913-3806-000
C17	CAPACITOR .02 μ f 1 kV	962-0915-000

parts list

SYMBOL	DESCRIPTION	COLLINS PART NUMBER
CR1	RECTIFIER	353-6333-000
<u>CR2</u>	DIODE 1N4006	353-6442-030
CR3	DIODE 1N4006	353-6442-030
CR4	DIODE 1N4006	353-6442-030
CR5	DIODE 1N1202	353-1889-000
CR6	DIODE 1N1202	353-1889-000
CR7	DIODE 1N1202	353-1889-000
CR8	DIODE 1N1202	353-1889-000
<u>CR9</u>	DIODE 1N4003	353-6442-030
<u>CR10</u>	DIODE 1N4003	353-6442-030
<u>CR11</u>	DIODE 1N4003	353-6442-030
<u>CR12</u>	DIODE 1N4003	353-6442-030
<u>CR13</u>	DIODE 1N4003	353-6442-030
CR14	DIODE 1N4003	353-6442-030
<u>CR15</u>	DIODE 1N4003	353-6442-030
<u>CR16</u>	DIODE 1N4003	353-6442-030
CR17	DIODE	353-0283-100
<u>CR18</u>	DIODE 1N4003	353-6442-030
E11	ARRESTOR	013-1332-020
K1	RELAY	970-2426-070
K2	RELAY	401-0015-020

SYMBOL	DESCRIPTION	COLLINS PART NUMBER
ASSEMBLY: A2 CONTROL CIRCUITS AND LOW VOLTAGE SUPPLIES, CPN 632-0021-001		
L1	INDUCTOR 10 Hy	678-0156-010
L2	INDUCTOR 10 Hy	678-0156-010
<u>L3</u>	REACTOR 16 Hy	668-0163-010
Q1	TRANSISTOR 2N3055	353-0583-010
Q2	TRANSISTOR 2N3054	353-0581-010
<u>Q3</u>	TRANSISTOR 2N4037	352-0714-020
<u>Q4</u>	TRANSISTOR 2N3053	352-0613-010
<u>Q5</u>	TRIAC SC45D	353-6490-030
<u>Q6</u>	TRANSISTOR 2N3053	352-0613-010
<u>Q7</u>	TRANSISTOR 2N3053	352-0613-010
<u>Q8</u>	TRIAC SC45D	353-6490-030
R1	RESISTOR, VARIABLE 1 K 25 W	735-1013-200
R2	RESISTOR 7.5 K 55 W	747-2857-000
R3	RESISTOR 150 Ohm 11 W	746-6145-000
<u>R4</u>	RESISTOR 750 K 2 W	705-1493-020
<u>R5</u>	RESISTOR 10 K 1/2 W	745-1394-000
<u>R6</u>	RESISTOR 8.87K 1/2 W	705-7320-000
<u>R7</u>	RESISTOR 470 Ohm 2 W	745-5596-000
R8	RESISTOR 1.2 K 14 W	747-0766-000
R9	RESISTOR 1.5 K 11 W	746-6161-000
R10	RHEOSTAT 15 K 25 W	735-1013-510

parts list

SYMBOL	DESCRIPTION	COLLINS PART NUMBER
R11	RESISTOR 5 K 1/2 W	746-6169-000
<u>R12</u>	RESISTOR 287 K 1/2 W	705-7214-000
<u>R13</u>	RESISTOR 33 K 1/2 W	745-1415-000
<u>R14</u>	RESISTOR 1 K 1/2 W	745-1352-000
<u>R15</u>	RESISTOR 470 Ohm 1 W	745-3338-000
<u>R16</u>	RESISTOR 0.1 Ohm 3 W	747-5115-000
<u>R17</u>	RESISTOR 0.1 Ohm 3 W	747-5115-000
R18	RESISTOR 33 Ohm 6.5 W	747-5491-000
<u>R19</u>	RESISTOR 28.7 K 1/2 W	705-7166-000
<u>R20</u>	RESISTOR 13.3 K 1/2 W	705-7150-000
<u>R21</u>	RESISTOR 180 Ohm 1/2 W	745-1321-000
<u>R22</u>	RESISTOR 1.5 K 1 W	745-3359-000
<u>R23</u>	RESISTOR 100 Ohm 1 W	745-3310-000
<u>R24</u>	RESISTOR 220 Ohm 1/2 W	745-1324-000
<u>R25</u>	RESISTOR 2.2 K 1/2 W	745-1366-000
<u>R26</u>	RESISTOR 10 Ohm 1 W	745-3268-000
<u>R27</u>	RESISTOR 470 Ohm 1/2 W	745-1338-000
<u>R28</u>	RESISTOR 10 K Variable	380-3761-070
<u>R29</u>	RESISTOR 1 K 1/2 W	745-1352-000
<u>R30</u>	RESISTOR 1 K 1/2 W	745-1352-000
<u>R31</u>	RESISTOR 2.2 K 1/2 W	745-1366-000
<u>R32</u>	RESISTOR 100 Ohm 1 W	745-3310-000
<u>R33</u>	RESISTOR 220 Ohm 1/2 W	745-1324-000
<u>R34</u>	RESISTOR 10 Ohm 1 W	745-3268-000

SYMBOL	DESCRIPTION	COLLINS PART NUMBER
ASSEMBLY: A2 CONTROL CIRCUITS AND LOW VOLTAGE SUPPLIES, CPN 632-0021-001		
R35	RESISTOR 2.2 K 1/2 W	745-1366-000
R36	RESISTOR 390 Ohm 6.5 W	747-5452-000
R37	RESISTOR 150 Ohm 11 W	746-6145-000
R38	RESISTOR 15 K 2 W	745-5701-000
R39	RESISTOR 750 K 2 W	705-1493-020
R40	RESISTOR 390 Ohm 6.5 W	747-5452-000
S1	SWITCH	627-9743-007
S2	SWITCH	627-9743-006
T1	TRANSFORMER	662-0357-010
T2	TRANSFORMER	662-0358-010
TB1	TERMINAL BOARD	367-5160-000
TB2	TERMINAL BOARD	367-4200-000
TB3	TERMINAL BOARD	367-4100-000
TB4	TERMINAL BOARD	306-0778-000
TB5	TERMINAL BOARD	367-4160-000
TB6	TERMINAL BOARD	367-4160-000
U1	REGULATOR	351-1120-080
VR1	DIODE, ZENER 1N2988	353-1367-000
VR2	DIODE, ZENER 1N4751A	353-6481-470

SYMBOL	DESCRIPTION	COLLINS PART NUMBER
VR3	DIODE, ZENER 1N4734A	353-6481-130
XBT1	HOLDER BATTERY	139-2699-030
XBT2	HOLDER BATTERY	139-2699-030
SBT3	HOLDER BATTERY	139-2699-030
XBT4	HOLDER BATTERY	139-2699-030
XE11	HOLDER ARRESTOR	013-1332-010
XQ1	SOCKET TRANSISTOR	220-0968-010
XQ2	SOCKET TRANSISTOR	220-0968-020
XU1	SOCKET REGULATOR	220-0968-010

SYMBOL	DESCRIPTION	COLLINS PART NUMBER
ASSEMBLY: A3 H.V. RECTIFIER PANEL, CPN 632-0033-001		
A3A1	BOARD	632-0004-001
A3A2	ASSY	632-0049-001
C1	CAPACITOR 4.0 μ F 220 VAC	930-0773-040
C2	CAPACITOR .03 μ F 7.5 kV	930-0776-010
E2	ARRESTOR	013-1332-020
R1	RESISTOR 27 K 55 W	747-3823-000
R3	RESISTOR 4 Ohm	710-5076-060
R4	RESISTOR 4 Ohm	710-5076-060
T1	TRANSFORMER	662-0342-010
TB1	TERMINAL BOARD	367-4200-000
XE2	HOLDER ARRESTOR	013-1332-010

SYMBOL	DESCRIPTION	COLLINS PART NUMBER
ASSEMBLY: A3A1 METER MULTIPLIER, CPN 632-0004-001		
CR1	DIODE 1N4003	353-6442-030
CR2	DIODE 1N4003	353-6442-030
R1	RESISTOR 200 K 2 W	705-1493-050
R2	RESISTOR 200 K 2 W	705-1493-050
R3	RESISTOR 200 K 2 W	705-1493-050
R4	RESISTOR 200 K 2 W	705-1493-050
R5	RESISTOR 200 K 2 W	705-1493-050
R6	RESISTOR 200 K 2 W	705-1493-050
R7	RESISTOR 200 K 2 W	705-1493-050
R8	RESISTOR 200 K 2 W	705-1493-050
R9	RESISTOR 200 K 2 W	705-1493-050
R10	RESISTOR 200 K 2 W	705-1493-050
R11	RESISTOR 200 K 2 W	705-1493-050
R12	RESISTOR 200 K 2 W	705-1493-050
R13	RESISTOR 200 K 2 W	705-1493-050
R14	RESISTOR 200 K 2 W	705-1493-050
R15	RESISTOR 200 K 2 W	705-1493-050
R16	RESISTOR 200 K 2 W	705-1493-050
R17	RESISTOR 200 K 2 W	705-1493-050
R18	RESISTOR 200 K 2 W	705-1493-050
VR1	ZENER DIODE 1N4744A	353-6481-330
VR2	ZENER DIODE 1N4744A	353-6481-330
VR3	ZENER DIODE 1N4744A	353-6481-330

SYMBOL	DESCRIPTION	COLLINS PART NUMBER
ASSEMBLY: A3A2 RECTIFIER ASSEMBLY, CPN 632-0049-001		
C1	CAPACITOR .1 mF 500 V	913-3234-000
CR1	DIODE	353-0413-020
CR2	DIODE	353-0413-020
CR3	DIODE	353-0413-020
CR4	DIODE	353-0413-020
Q1	SCR 2N1799	353-1025-010
Q2	SCR 2N1799	353-1025-010
R1	RESISTOR 100 Ohm 2 W	745-5610-000

SYMBOL	DESCRIPTION	COLLINS PART NUMBER
ASSEMBLY: REMOTE CONTROL (OPTIONAL) CPN 632-0071-001		
CR1	DIODE 1N4006	353-6442-060
CR2	DIODE 1N4006	353-6442-060
Kk	RELAY	970-2454-270
K2	RELAY	970-2454-270
K3	RELAY	970-2454-270
K4	RELAY	970-2454-270
K5	RELAY	970-2454-270
K6	RELAY	970-2454-270
K7	RELAY	970-2454-270
K8	RELAY	970-2454-270
R1	RESISTOR 470 Ohm 3 W	747-5391-000
TB1	TERMINAL BOARD	367-0812-120

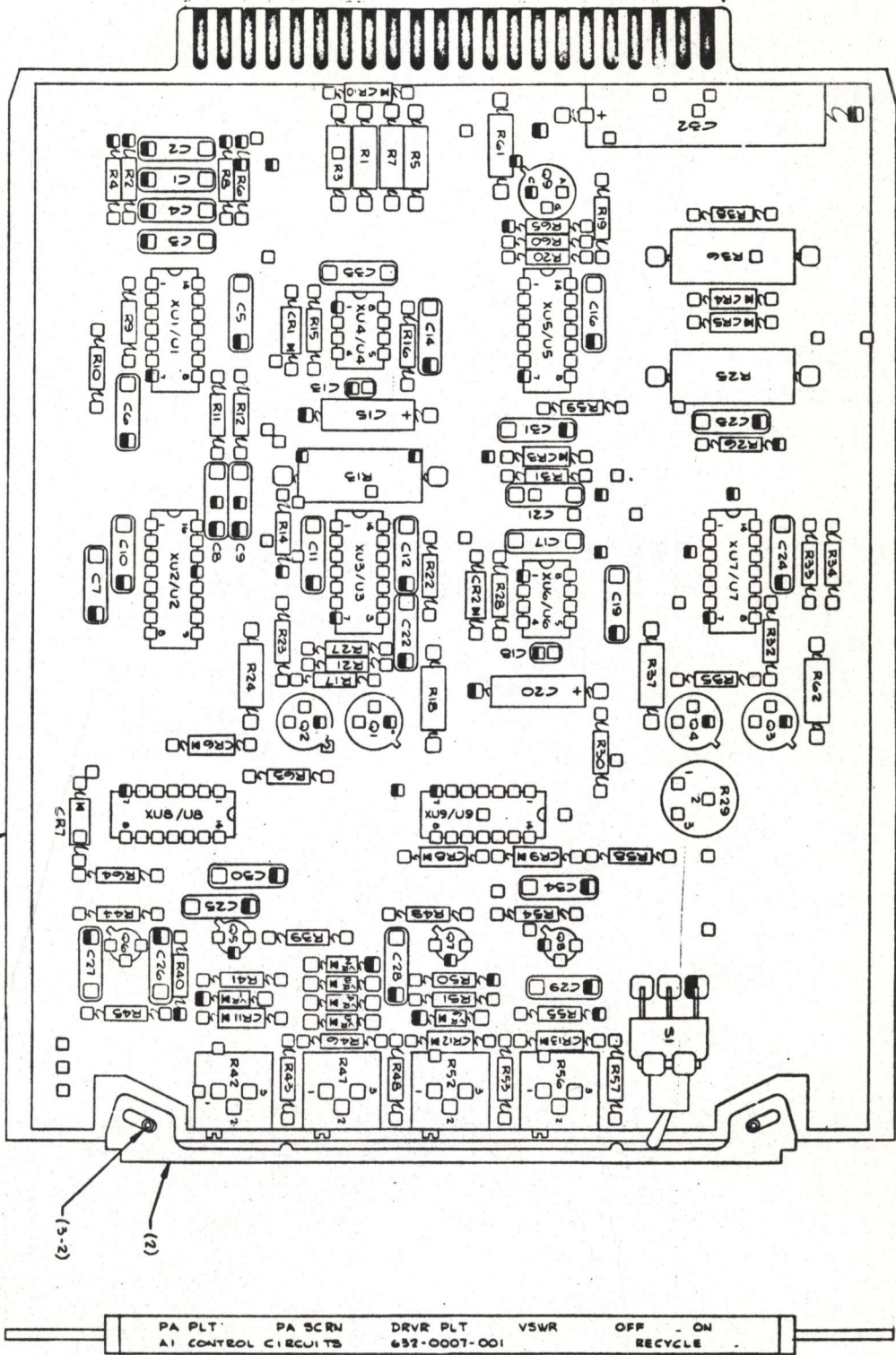

A1A1 CONTROL CIRCUITS CPN 632-0007-001

632-0007

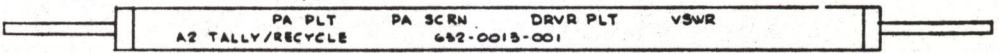
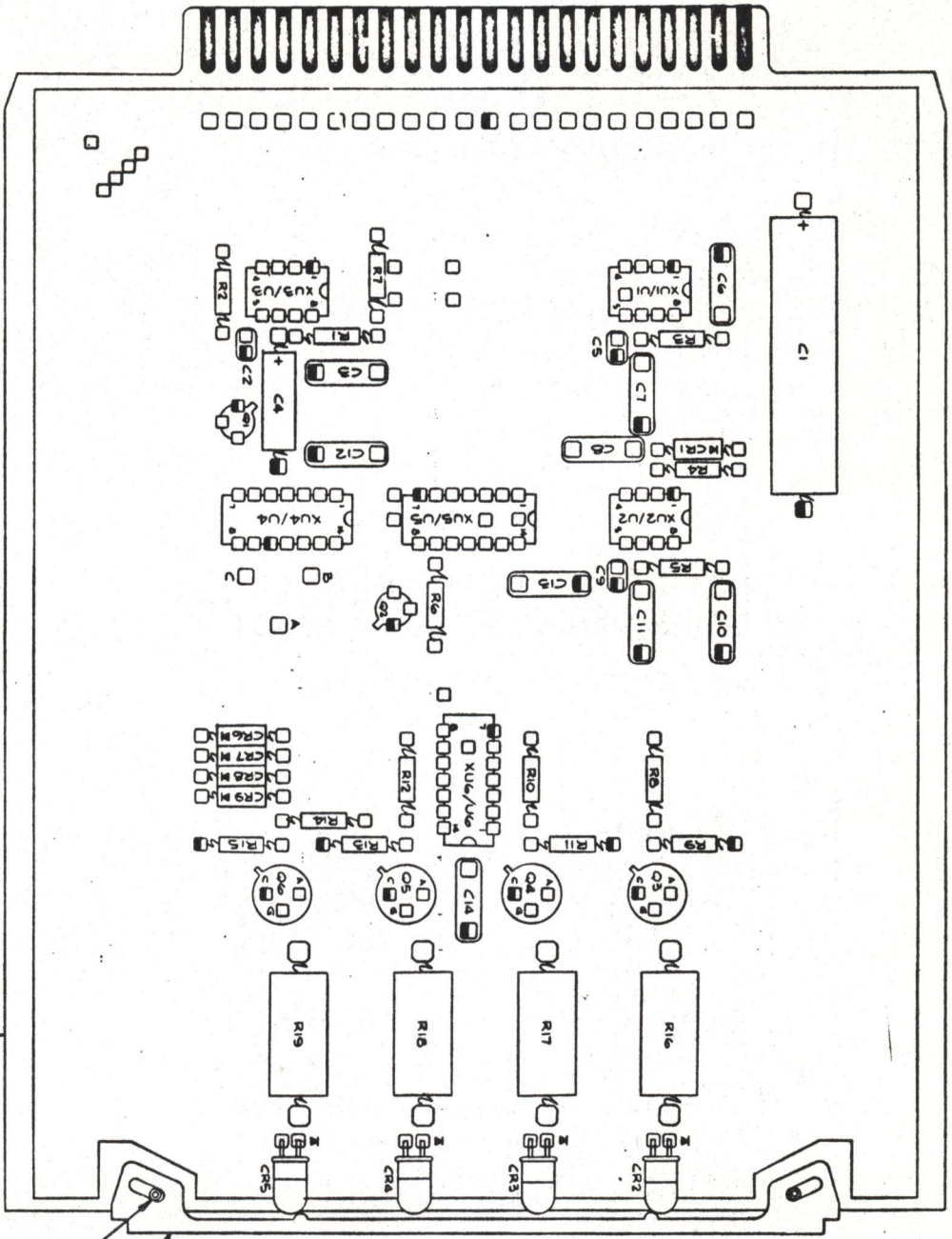

A1A2 OVL D TALLY/RECYCLE (OPTIONAL) CPN 632-0013-001

632-0013
REV. 1/78

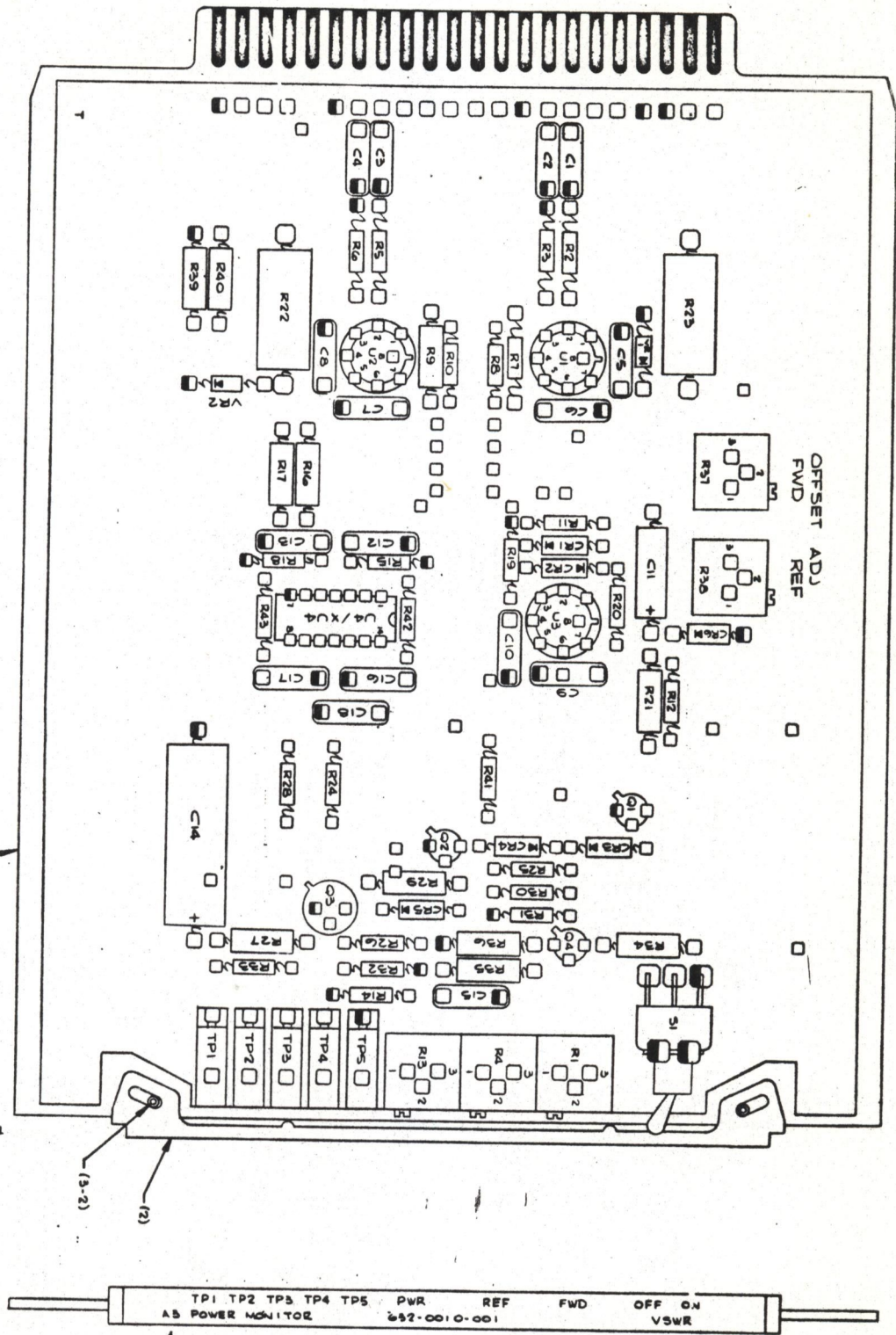

ATA3 POWER MONITOR CPN 632-0010-001

632-0010-001
 632-0010-001
 632-0010-001

ANODE LEAD (LONG TERM.)
TYP FOR BOTH Q5 AND Q6

GATE LEAD (SHORT TERM.)
TYP FOR BOTH Q5 AND Q6

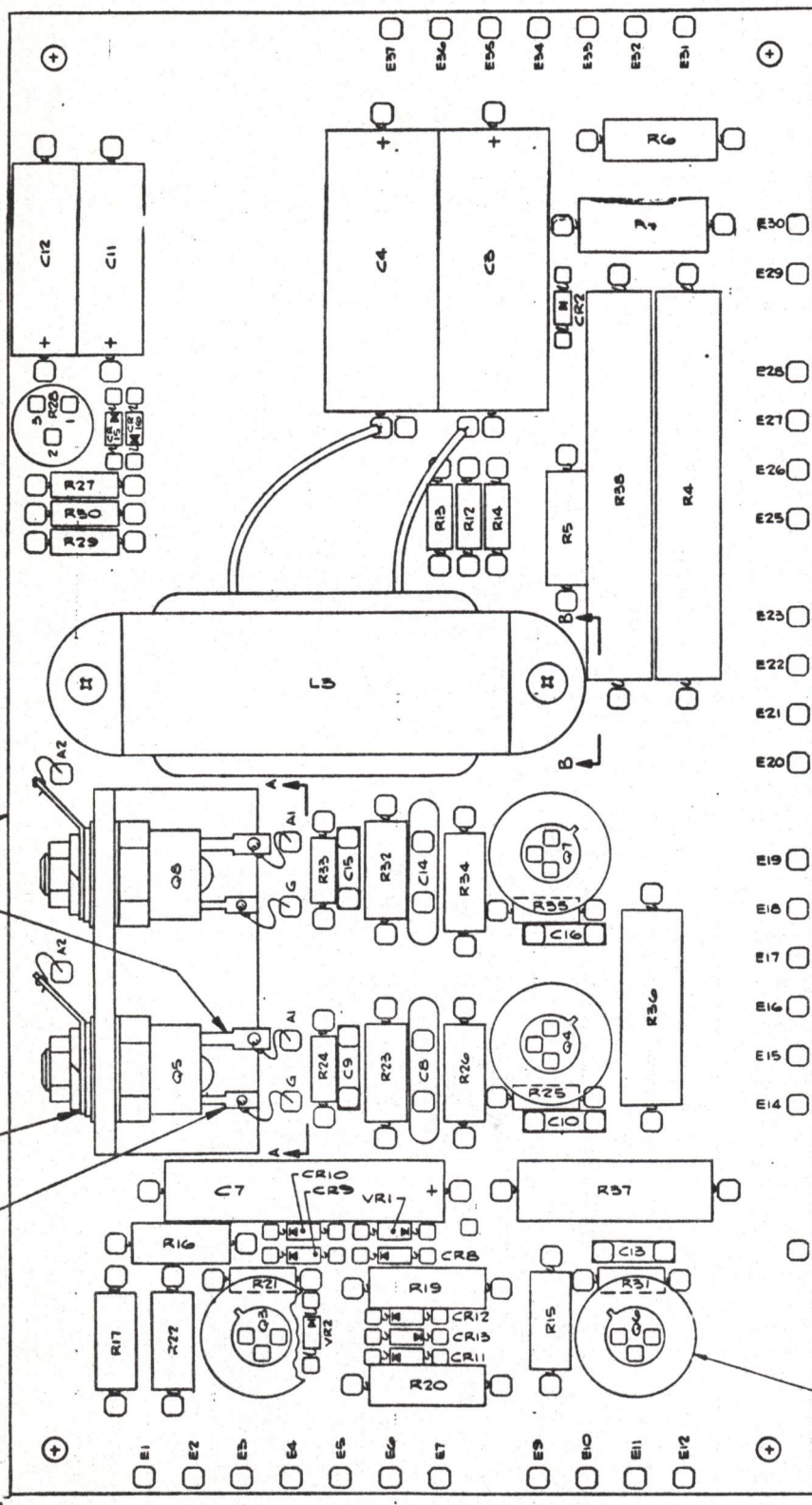

CONTROL CIRCUITS

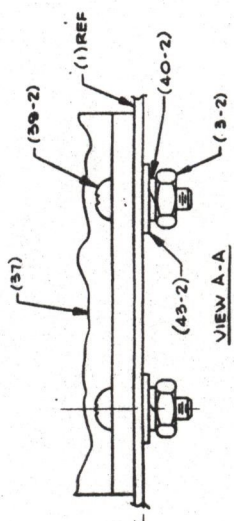
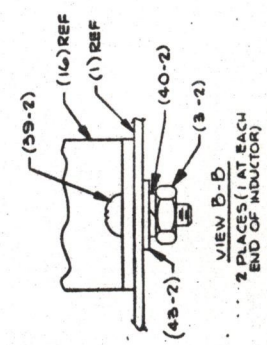

NOTE: THOSE COMPONENTS UNDERLINED ON PARTS LIST 632-0021-001 ARE LOCATED ON THIS BOARD.

E 13499 G
REV 4 11 67

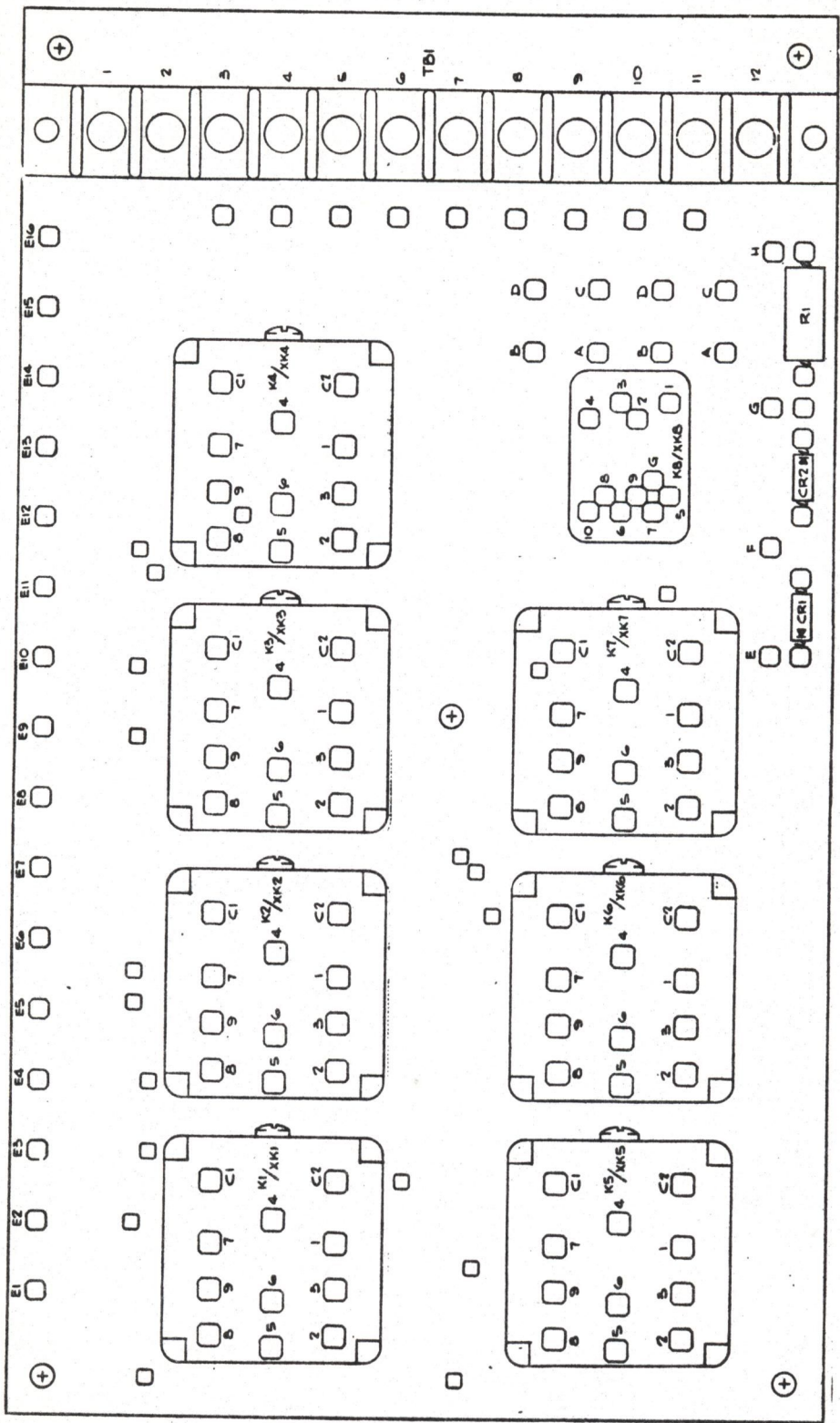

REMOTE CONTROL (OPTIONAL)

CPN 632-0071-001

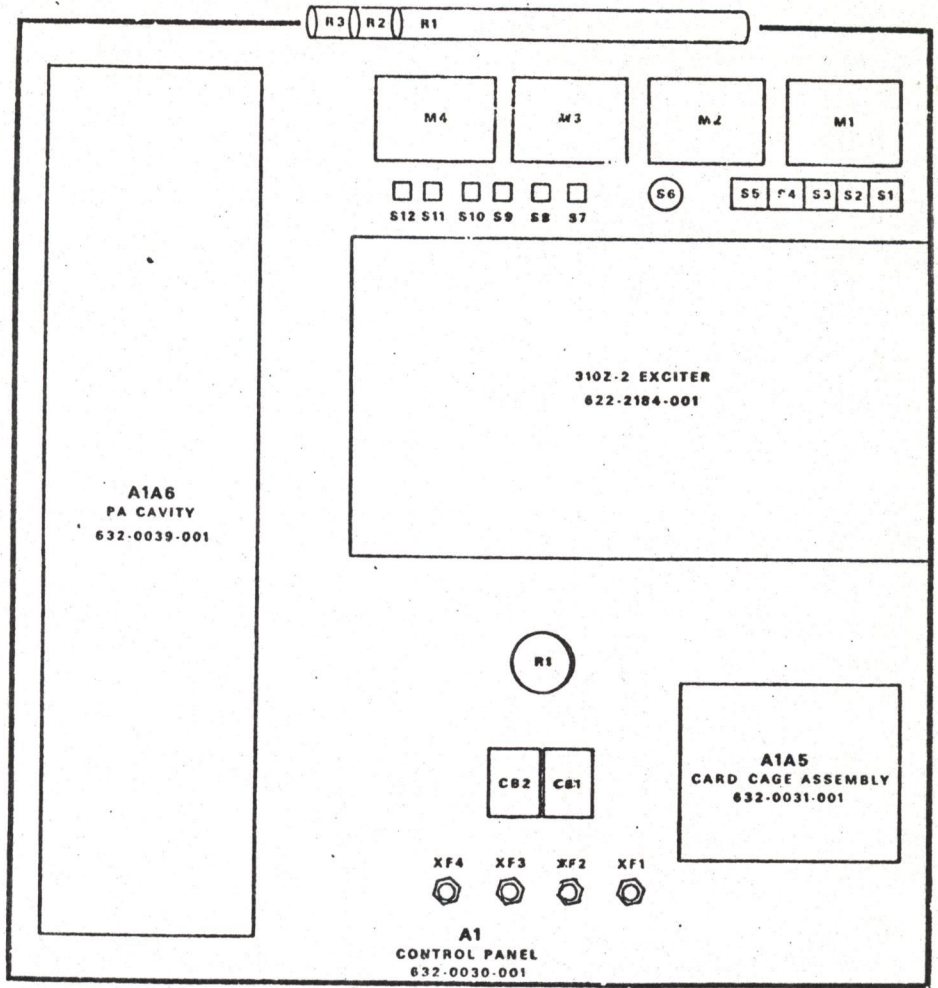

831D-2 , FRONT PANEL , BACK VIEW

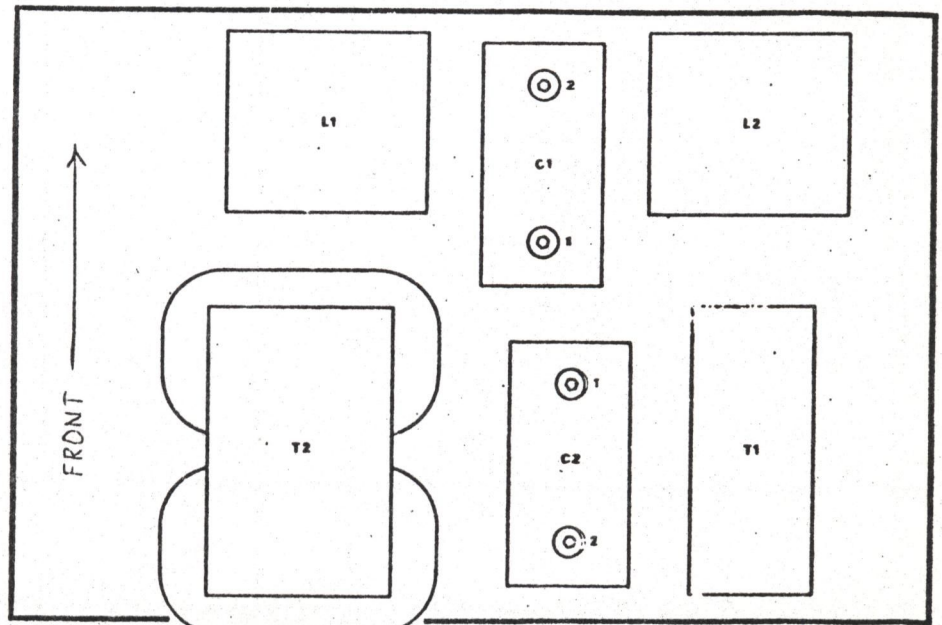

831D-2 , BOTTOM SECTION , TOP VIEW

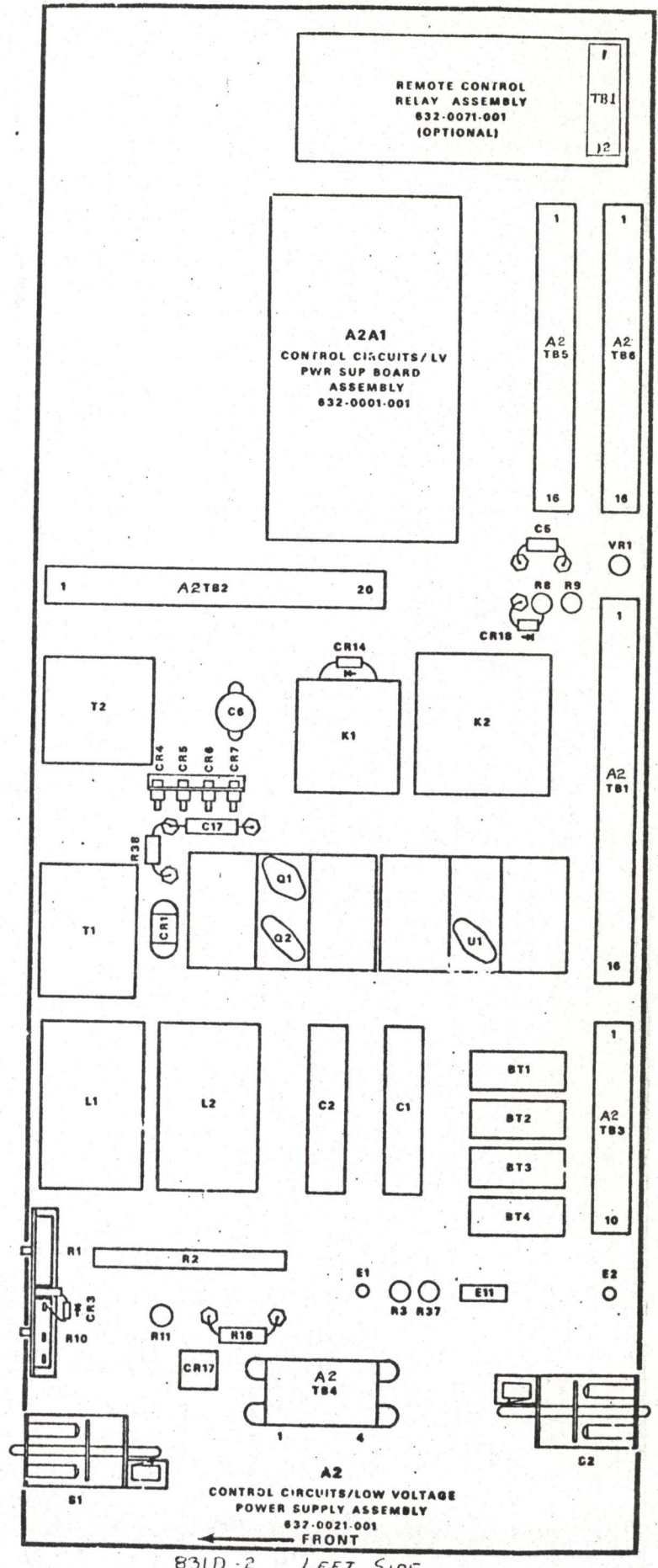

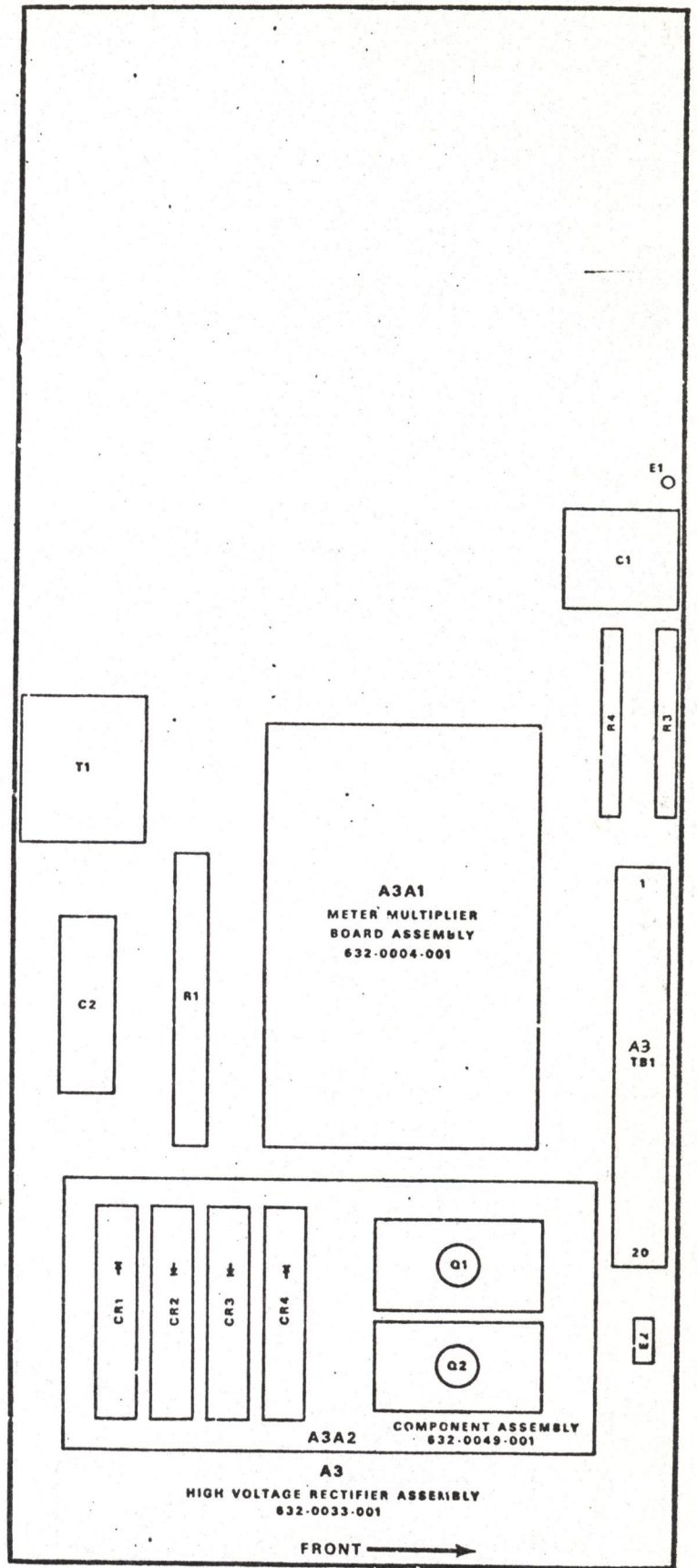

831D-2 , RIGHT SIDE

100 PRI
330 SEC

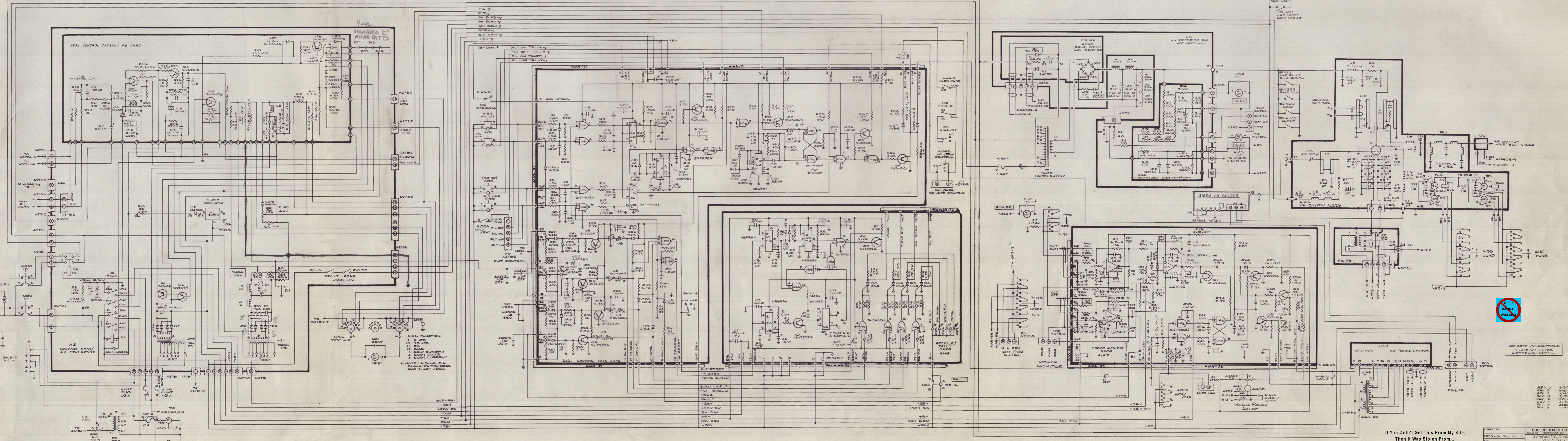

If You Didn't Get This From My Site,
Then It Was Stolen From...
www.SteamPoweredRadio.com

CONTRACT NO.	COLLINS RADIO COMPANY
PREP. CLERK: 8/17/75	DATE: 8/17/75
CHK:	REV. 0: 8/17/75
APD:	REV. 1: 8/17/75
	REV. 2: 8/17/75
	REV. 3: 8/17/75
	REV. 4: 8/17/75
	REV. 5: 8/17/75
	REV. 6: 8/17/75
	REV. 7: 8/17/75
	REV. 8: 8/17/75
	REV. 9: 8/17/75
	REV. 10: 8/17/75
	REV. 11: 8/17/75
	REV. 12: 8/17/75
	REV. 13: 8/17/75
	REV. 14: 8/17/75
	REV. 15: 8/17/75
	REV. 16: 8/17/75
	REV. 17: 8/17/75
	REV. 18: 8/17/75
	REV. 19: 8/17/75
	REV. 20: 8/17/75
	REV. 21: 8/17/75
	REV. 22: 8/17/75
	REV. 23: 8/17/75
	REV. 24: 8/17/75
	REV. 25: 8/17/75
	REV. 26: 8/17/75
	REV. 27: 8/17/75
	REV. 28: 8/17/75
	REV. 29: 8/17/75
	REV. 30: 8/17/75
	REV. 31: 8/17/75
	REV. 32: 8/17/75
	REV. 33: 8/17/75
	REV. 34: 8/17/75
	REV. 35: 8/17/75
	REV. 36: 8/17/75
	REV. 37: 8/17/75
	REV. 38: 8/17/75
	REV. 39: 8/17/75
	REV. 40: 8/17/75
	REV. 41: 8/17/75
	REV. 42: 8/17/75
	REV. 43: 8/17/75
	REV. 44: 8/17/75
	REV. 45: 8/17/75
	REV. 46: 8/17/75
	REV. 47: 8/17/75
	REV. 48: 8/17/75
	REV. 49: 8/17/75
	REV. 50: 8/17/75
	REV. 51: 8/17/75
	REV. 52: 8/17/75
	REV. 53: 8/17/75
	REV. 54: 8/17/75
	REV. 55: 8/17/75
	REV. 56: 8/17/75
	REV. 57: 8/17/75
	REV. 58: 8/17/75
	REV. 59: 8/17/75
	REV. 60: 8/17/75
	REV. 61: 8/17/75
	REV. 62: 8/17/75
	REV. 63: 8/17/75
	REV. 64: 8/17/75
	REV. 65: 8/17/75
	REV. 66: 8/17/75
	REV. 67: 8/17/75
	REV. 68: 8/17/75
	REV. 69: 8/17/75
	REV. 70: 8/17/75
	REV. 71: 8/17/75
	REV. 72: 8/17/75
	REV. 73: 8/17/75
	REV. 74: 8/17/75
	REV. 75: 8/17/75
	REV. 76: 8/17/75
	REV. 77: 8/17/75
	REV. 78: 8/17/75
	REV. 79: 8/17/75
	REV. 80: 8/17/75
	REV. 81: 8/17/75
	REV. 82: 8/17/75
	REV. 83: 8/17/75
	REV. 84: 8/17/75
	REV. 85: 8/17/75
	REV. 86: 8/17/75
	REV. 87: 8/17/75
	REV. 88: 8/17/75
	REV. 89: 8/17/75
	REV. 90: 8/17/75
	REV. 91: 8/17/75
	REV. 92: 8/17/75
	REV. 93: 8/17/75
	REV. 94: 8/17/75
	REV. 95: 8/17/75
	REV. 96: 8/17/75
	REV. 97: 8/17/75
	REV. 98: 8/17/75
	REV. 99: 8/17/75
	REV. 100: 8/17/75

COLLINS 83102

2.5 kW FM
XMTX

FREQ 94.3 MHz
STATION KEZZ

UNIT S/N 229
DATE 1980
TECH _____

TEST LIMITS

8.2.4.2 METER READINGS

	<u>NOMINAL</u>			<u>TEST READINGS</u>
FREQ. (MHz)	108	98	88	
PLATE VOLTAGE (V)	4780	4770	4650	<u>4410</u>
PLATE CURRENT (A)	.79	.79	.78	<u>0.805</u>
GRID CURRENT (mA)	9.3	9.5	9.8	<u>11.0</u>
SCREEN CURRENT (mA)	90	80	84	<u>80</u>
SCREEN VOLTAGE (V)	540	525	525	<u>450</u>
POWER OUT (W)	2500	2500	2500	<u>2500</u>

8.2.4.4 EFFICIENCY = $\frac{\text{POWER}}{\text{PLATE VOLTS} \times \text{PLATE CURRENT}}$

$\frac{2500 \text{ WATTS}}{(4400 \text{ V})(.805 \text{ A})}$

70.2 SEE CHART

8.2.4.4 METER ACCURACY

	<u>EQUIPMENT METER</u>	<u>STANDARD</u>	
PLATE VOLTAGE	<u>4420</u>	<u>4380</u>	0.9% error
PLATE CURRENT	<u>0.805</u>	<u>0.810</u>	0.6% error

EQUIPMENT METERS SHALL BE WITHIN 2% OF STANDARD.

8.2.5 WATTMETER CALIBRATION ✓ OK

8.2.6 REFLECTED POWER OVERLOAD ADJUST ✓ OK

8.2.7 MANUAL POWER CONTROL ✓ OK

8.2.8 AUTOMATIC POWER CONTROL ✓ OK

8.2.9 MONITOR OUTPUT

A1A6J2 OUTPUT	<u>8.0</u>	8 ± 2 V
A1A6J3 OUTPUT	<u>8.2</u>	8 ± 2 V

8.2.10 REMOTE CONTROL OPERATION

8.2.10.1 28/48 V DC NEGATIVE COMMON

8.2.10.1.1 FAIL SAFE NA OK

SIZE A	CODE IDENT 13499	DWG NO. 669-7781
SCALE	REV	SHEET 28

COLLINS 83102 2.5KW FM XMITR

REDUCED POWER LEVELS

P_{OUT}	PLATE VOLTS	PLATE I	SCREEN VOLTS	SCREEN I	GRID I	EFF.
2500W	4720	790 MA	525	80 MA	9.5 MA	66.3
2000	4410	685	490	75	9.3	66.0
1800	4480	595	450	73	9.2	67.6
1600	4490	520	415	65	9.2	68.6
1400	4450	460	380	88	9.3	68.4
1200	4450	395	335	35	9.3	68.3
1000	4450	335	320	42	9.3	67.2
500	2250	340	270	54	4.0	65.4

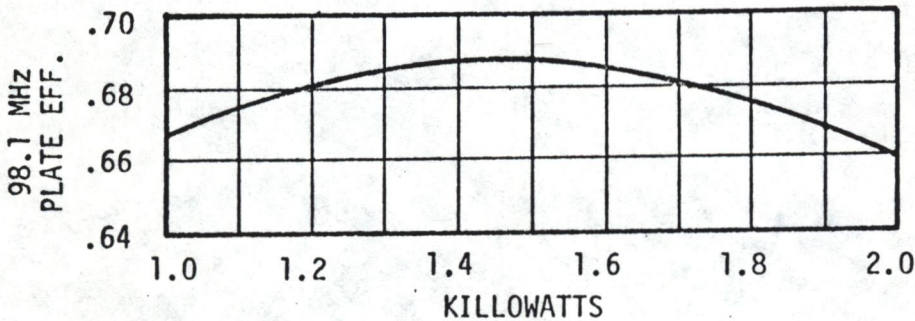
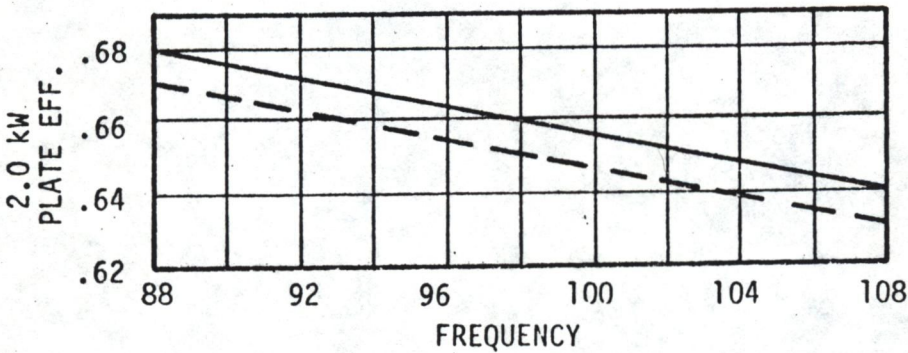
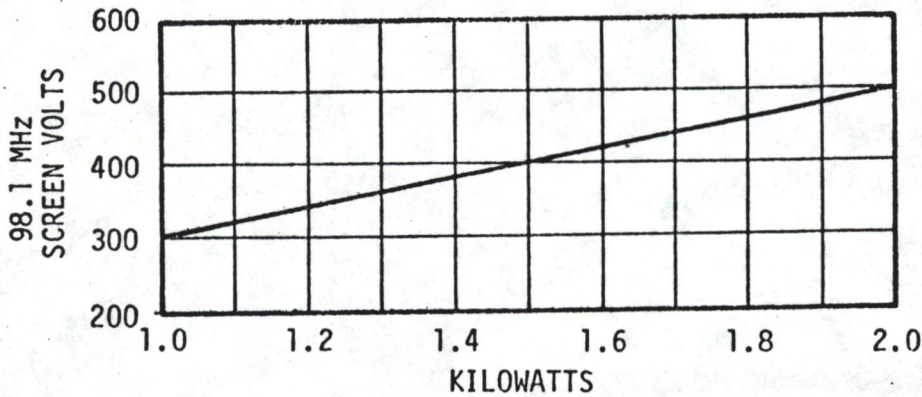

If You Didn't Get This From My Site,
Then It Was Stolen From...
www.SteamPoweredRadio.com

SIZE A	CODE IDENT 13499	DWG NO. 669-7781
SCALE	REV	SHEET 34

W J O N

Unit S/N 134
Date 11-14-69
Tech 79237

REV

DATA SHEET REQUIREMENTS

831D-1 FM Transmitter, CPN 522-4692-001

TEST LIMITS

8.1	<u>PRELIMINARY TESTS</u>	
8.1.1	<u>EXCITER</u>	
	310Z-1 Production Test Requirements Performed	OK
8.1.2	<u>VISUAL INSPECTION</u>	OK
8.1.3	<u>BLEEDER AND SHORTING SWITCHES</u>	
	Screen Bleeder	OK
	HV Bleeder	OK
	Right Shorting Switch	OK
	Left Shorting Switch	OK
	PA Grid Shorting Switch	OK
	PA Cavity Shorting Switch	OK
	HV Shorting Stick Installed	OK
8.1.4	<u>TRANSFORMER TAPS SET</u>	OK
8.1.5	<u>PRELIMINARY TESTS COMPLETED</u>	OK
8.1.6	<u>FUSES</u>	OK
8.1.7	<u>PRIMARY POWER INPUT</u>	OK
8.1.8	<u>25 VOLT POWER SUPPLY</u>	27-30
8.1.9	<u>LOW LEVEL TURN-ON</u>	OK
8.1.10	<u>INTERLOCKS</u>	
	Right	OK
	Left	OK
	PA Grid	OK
	PA Cavity	OK
8.1.11	<u>AIR SWITCH ADJUSTMENT</u>	OK
8.1.12	<u>FILAMENT VOLTAGE</u>	
	Minimum Limit	4.1 NLT 4.5 V
	Maximum Limit	5.25 NLT 5.3 V
	Adjust	5.0 5 ± 0.2 V

SIZE A	CODE IDENT NO. 13499	DWG. NO. 509-5985-001
SCALE NONE	WT	SEE SHEET 1
		SHEET 1

Unit S/N _____
 Date _____
 Tech _____

REV _____

8.1.13 PRELIMINARY BIAS ADJUST

TEST LIMITS

Minimum Limit
 Maximum Limit
 Adjust

65 NMT 95V
60.5 NLT 100V
95 95 +5

8.1.14 PA TUNING AND LOADING CONTROLS

Plate Tuning/Loading Limit Switches Operate.

OK

8.1.15 PLATE TIME DELAY

Time Delay Closes (Cold)

170.9 160 +20 sec.

8.1.16 PRELIMINARY OVERLOAD ADJUST

OK

8.2. INITIAL ADJUSTMENTS

8.2.1 STATIC PLATE CURRENT ADJUST

OK

8.2.2 EXCITER TUNED

OK

8.2.3 TUNING AND LOADING

8.2.3.1 GRID TUNING

OK

8.2.3.2 PLATE TUNING AND LOADING

OK

8.2.3.3 EFFICIENCY = $\frac{\text{POWER}}{\text{PLATE VOLTS} \times \text{PLATE CURRENT}}$

$\frac{\text{WATTS}}{(4,320 \text{ V})(.682 \text{ ma})}$

67.8 NLT .64

8.2.4 OVERLOAD ADJUST

NMT 850 ma

8.2.5 WATTMETER CALIBRATION

OK

8.2.6 REFLECTED POWER OVERLOAD ADJUST

OK

8.2.7 AUTOMATIC POWER CONTROL

OK

8.2.8 MONITOR OUTPUT

A10L1 Output
 A10L2 Output

9.30
7.25

9 +1 V
 9 +1 V

8.2.9 REMOTE CONTROL OPERATION

SIZE A	CODE IDENT NO. 13499	DWG. NO. 569-5985-001
SCALE NONE	WT	SEE SHEET 1
		SHEET 19

8.2.9.1	<u>28/48 V DC NEGATIVE GROUNDED (If Applicable)</u>	
8.2.9.1.1	<u>FAIL SAFE</u>	TEST LIMITS OK
8.2.9.1.2	<u>POWER ON AND OFF</u>	OK
8.2.9.1.3	<u>TUNING AND LOADING</u>	
	Tuning	OK
	Loading	OK
8.2.9.1.4	<u>POWER CHANGE</u>	OK
8.2.9.1.5	<u>REMOTE STEREO</u>	OK
8.2.9.1.6	<u>FAULT</u>	OK
8.2.9.1.7	<u>METER READINGS</u>	
	TP2, Fil. Voltage Adjust	5V +0.2
	TP3, Bias Voltage, 1 V Per 100 V	9.2V +10% of Local
		Meter Reading
	TP4, Grid Current, 3 V Per 30 ma	+10% " "
	TP5, Screen Current, 1 V Per 15 ma	+10% " "
	TP6, Screen Voltage, 1 V Per 150 V	-10% " "
	TP7, 28 V Supply, Direct	28.1 27 - 30
	TP8, Plate Voltage, 1 V Per 600 V	+10% " "
	TP9, Plate Current, 1 V = 0.1 Amp	+10% " "
	TP10, FWD Power	3.5 2 V +0.5
	TP11, Ref. Power	2.5 2.5 +0.5

8.2.9.2	<u>28/48 V POSITIVE GROUNDED (If Applicable)</u>	
	Power Change	OK
	Remote Stereo	OK
8.2.9.3	<u>117 V AC REMOTE SUPPLY (If Applicable)</u>	not applicable
	Power Change	OK
	Remote Stereo	OK

8.3 FREQUENCY RESPONSE
 Pre-Emphasis In

SIZE A	CODE IDENT NO. 13499	DWG. NO. 569-5985-001
SCALE NONE	WT	SEE SHEET 1
		SHEET 20

8.3.1

LEFT CHANNEL

50 Hz	2	DB
100	2.1	DB
400	2.2	DB
1000	3.1	DB
5000	10.9	DB
7500	13.7	DB
10,000	15.5	DB
15,000	17.1	DB

REFERENCE

0.5 to 3.5 DB
0.6 to 3.6 DB
1.4 to 4.4 DB
8.7 to 11.7 DB
11.8 to 14.8 DB
14.2 to 17.1 DB
17.0 to 21.0 DB

8.3.2

RIGHT CHANNEL

50 Hz	2	DB
100	2.1	DB
400	2.2	DB
1000	3.1	DB
5000	11.1	DB
7500	13.9	DB
10,000	15.7	DB
15,000	17.0	DB

REFERENCE

0.5 to 3.5 DB
0.6 to 3.6 DB
1.4 to 4.4 DB
8.7 to 11.7 DB
11.8 to 14.8 DB
14.2 to 17.1 DB
17.0 to 21.0 DB

8.4

CHANNEL SEPARATION

8.4.1

TRANSMIT LEFT CHANNEL

50 Hz	-38.5	DB
100	-41	DB
1000	-43.5	DB
5000	-47	DB
7500	-47	DB
10,000	-50	DB
15,000	-50	DB

NLT -29 DB
NLT -29 DB
NLT -29 DB
NLT -29 DB
NLT -29 DB
NLT -29 DB
NLT -29 DB

8.4.2

TRANSMIT RIGHT CHANNEL

50 Hz	-39	DB
100	-41.5	DB
1000	-44	DB
5000	-46	DB
7500	-45	DB
10,000	-47	DB
15,000	-42	DB

NLT -29 DB
NLT -29 DB
NLT -29 DB
NLT -29 DB
NLT -29 DB
NLT -29 DB
NLT -29 DB

8.5

HARMONIC DISTORTION

Monaural

	R	L
50 Hz	%	35 %
100	%	41 %
400	%	34 %
1000	%	26 %
5000	%	31 %
7500	%	38 %
10,000	%	32 %
15,000	%	24 %

Not applicable

NMT 1.0%
NMT 1.0%
NMT 1.0%
NMT 1.0%
NMT 1.0%
NMT 1.0%
NMT 1.0%
NMT 1.0%

SIZE A	CODE IDENT NO. 13499	DWG. NO. 569-5985-001
SCALE NONE	WT	SEE SHEET 1
		SHEET 21

Stereo	R	L	
50 Hz	72 %	59 %	NMT 1.0%
100	41 %	61 %	NMT 1.0%
400	74 %	61 %	NMT 1.0%
1000	81 %	62 %	NMT 1.0%
5000	84 %	65 %	NMT 1.0%
7500	83 %	64 %	NMT 1.0%
10,000	83 %	64 %	NMT 1.0%
15,000	86 %	67 %	NMT 1.0%

8.6 FM NOISE

8.6.1 MAIN CHANNEL

Noise level -67 DB NMT -65 DB

8.6.2 SUB CHANNEL:

Noise Level -75 DB NMT -65 DB

8.7 AM NOISE

Noise level -58 DB NMT -55 DB

8.8 CROSSTALK

8.8.1 MAIN INTO SUB CHANNEL

all readings are below 40 DB

50 Hz	DB	NMT -40 DB
100	DB	NMT -40 DB
400	DB	NMT -40 DB
1000	DB	NMT -40 DB
5000	DB	NMT -40 DB
7500	DB	NMT -40 DB
10,000	DB	NMT -40 DB
15,000	DB	NMT -40 DB

8.8.2 SUB CHANNEL INTO MAIN

50 Hz	DB	NMT -40 DB
100	DB	NMT -40 DB
400	DB	NMT -40 DB
1000	DB	NMT -40 DB
5000	DB	NMT -40 DB
7500	DB	NMT -40 DB
10,000	DB	NMT -40 DB
15,000	DB	NMT -40 DB

If You Didn't Get This From My Site,
 Then It Was Stolen From...
www.SteamPoweredRadio.com

SIZE A	CODE IDENT NO. 13499	DWG. NO. 569-5985-001
SCALE NONE	WT	SEE SHEET 1
		SHEET 22

523-0563912-001431
1 February 1975



**Rockwell
International**

Collins instruction book

310Z-2 FM Exciter



Broadcast Division
Collins Radio Group
Rockwell International
Dallas, Texas 75207

Printed in United States of America

	Page
Section 1 General Description	1-1
1.1 Introduction	1-1
1.2 Physical Description	1-1
1.3 Functional Description	1-1
1.4 Optional Equipment	1-2
1.5 Technical Characteristics	1-2
1.5.1 General	1-2
1.5.2 Monaural FM	1-3
1.5.3 Stereo FM With 786V-1	1-4
1.5.4 SCA FM With 786W-1	1-4
1.5.5 Composite Stereo STL With 785E-1	1-5
Section 2 Installation	2-1
2.1 General	2-1
2.2 Preinstallation	2-1
2.3 Wiring	2-1
2.3.1 Audio Input Connections	2-1
2.3.2 Stereo Remote Control	2-3
2.3.3 RF Output	2-3
2.3.4 Input Power	2-3
2.3.5 Power Control Override	2-3
2.4 Initial Checks	2-3
2.5 Output Frequency Change	2-3
Section 3 Operation	3-1
3.1 General	3-1
3.2 Normal Turn-On Procedure	3-1
3.3 Alternate Turn-On Procedure	3-1
3.4 Stereo/Monaural Remote Switching	3-1
Section 4 Theory of Operation	4-1
4.1 General	4-1
4.2 Block Diagram Discussion	4-1
4.3 Stereo Generator A2	4-2
4.3.1 Signals Required	4-2
4.3.2 Method of Signal Generation in 786V-1 Stereo Generator	4-2
4.3.3 Analysis of Signals Generated	4-6
4.3.4 Circuit Analysis	4-8

table of contents (cont)

	Page
4.4 SCA Generator A1/A2	4-9
4.4.1 General	4-9
4.4.2 Circuit Analysis	4-9
4.5 FM Modulator A4	4-10
4.6 Audio/Regulator Card A7	4-12
4.7 785E-1 STL Interface Card A3	4-12
4.8 RF Amplifier A5	4-13
4.9 Power Supplies	4-13
4.10 Meter Amplifier	4-14
Section 5 Maintenance	5-1
5.1 General	5-1
5.2 Cleaning	5-1
5.3 Lubrication	5-2
5.4 Inspection	5-2
5.5 Test Equipment Required	5-2
5.6 Alignment and Adjustment	5-3
5.6.1 Power Supply Checks and Adjustments	5-3
5.6.2 Modulator Tests	5-3
5.6.3 Audio Adjustments - Preemphasis Tracking and Linear Crosstalk	5-7
5.6.4 SCA Generator Output Level Adjustment	5-8
5.6.5 SCA Generator Frequency Adjustment	5-8
5.6.6 Stereo Generator Adjustment	5-8
5.7 Minimum Performance Standards	5-9
5.7.1 Output Frequency	5-9
5.7.2 Output Power	5-9
5.7.3 FM Noise	5-9
5.7.4 Frequency Response (Monaural)	5-10
5.7.5 Harmonic Distortion (Monaural)	5-11
5.7.6 Frequency Response (Stereo)	5-11
5.7.7 Harmonic Distortion (Stereo)	5-11
5.7.8 Subcarrier Suppression	5-12
5.7.9 Channel Separation	5-12
5.7.10 Main Channel to Subchannel Nonlinear Crosstalk	5-13
5.7.11 Subchannel to Main Channel Nonlinear Crosstalk	5-14
5.7.12 SCA Input Test	5-14
5.7.13 SCA Noise Test	5-16
5.7.14 SCA Mute Circuit Test	5-16
5.7.15 SCA Frequency Response	5-17
5.8 Frequency Change	5-17

table of contents (cont)

	Page
Section 6 Parts List	6-1
6.1 General	6-1
6.2 Ordering Replacement Parts	6-1
Section 7 Diagrams	7-1

list of illustrations

Figure	Page
1-1 310Z-2 FM Broadcast Exciter	1-0
2-1 310Z-2 FM Exciter, Outline Dimensions and Installation Details	2-2
3-1 310Z-2 FM Exciter, Front Panel Controls and Indicators	3-2
4-1 310Z-2 FM Exciter, Simplified Block Diagram	4-3
4-2 Spectrum of Signals in Stereo Baseband Audio	4-5
4-3 Elementary Time-Division Multiplex System	4-5
4-4 Balanced Modulator Output When $L + R = 2$; $L - R = 0$	4-7
4-5 Balanced Modulator Output When $L + R = 1$; $L - R = 1$	4-7
4-6 Balanced Modulator Output When $L + R = 0$; $L - R = 2$	4-8
5-1 310Z-2 FM Exciter, Maintenance Controls	5-4
5-2 Test Equipment Connections to 310Z-2 for Adjustment and Test Procedures	5-6
5-3 Stereo Test Circuit, Schematic Diagram	5-7
5-4 Test Equipment Connections to 310Z-2 for Crosstalk Test	5-14
5-5 Nonlinear Crosstalk Test Circuit, Schematic Diagram	5-15
6-1 310Z-2 FM Exciter (Sheet 1 of 3)	6-2

list of illustrations (cont)

Figure		Page
6-2	310Z-2 FM Exciter (Sheet 2 of 3)	6-3
6-3	310Z-2 FM Exciter (Sheet 3 of 3)	6-4
6-4	Extender Board	6-7
6-5	SCA Generator 786W-1 A1, A2	6-9
6-6	STL Interface 785E-1 A3	6-13
6-7	Stereo Generator 786V-1 A3	6-15
6-8	Modulator/Exciter A4 (Sheet 1 of 2)	6-18
6-9	Modulator/Exciter A4 (Sheet 2 of 2)	6-19
6-10	Power Amplifier A5	6-23
6-11	Audio/Mtr Regulator A6	6-25
7-1	310Z-2 FM Exciter, Detail Block Diagram	7-3
7-2	310Z-2 FM Exciter Main Frame, Schematic Diagram	7-5
7-3	786W-1 SCA Generators A1/A2, Schematic Diagram	7-9
7-4	786V-1 Stereo Generator A3, Schematic Diagram	7-11
7-5	FM Modulator A4, Schematic Diagram	7-13
7-6	RF Amplifier A5, Schematic Diagram	7-15
7-7	785E-1 STL Interface Card A3, Schematic Diagram	7-16

list of tables

Table		Page
1-1	310Z-2 FM Exciter Special Features and Customer Options	1-3
3-1	310Z-2 FM Broadcast Exciter, Front Panel Controls and Indicators	3-3
3-2	Test Meter Indications	3-3
5-1	Required Test Equipment	5-2
5-2	Maintenance Controls	5-5
5-3	Tests	5-10
5-4	Crystal Part Number	5-18

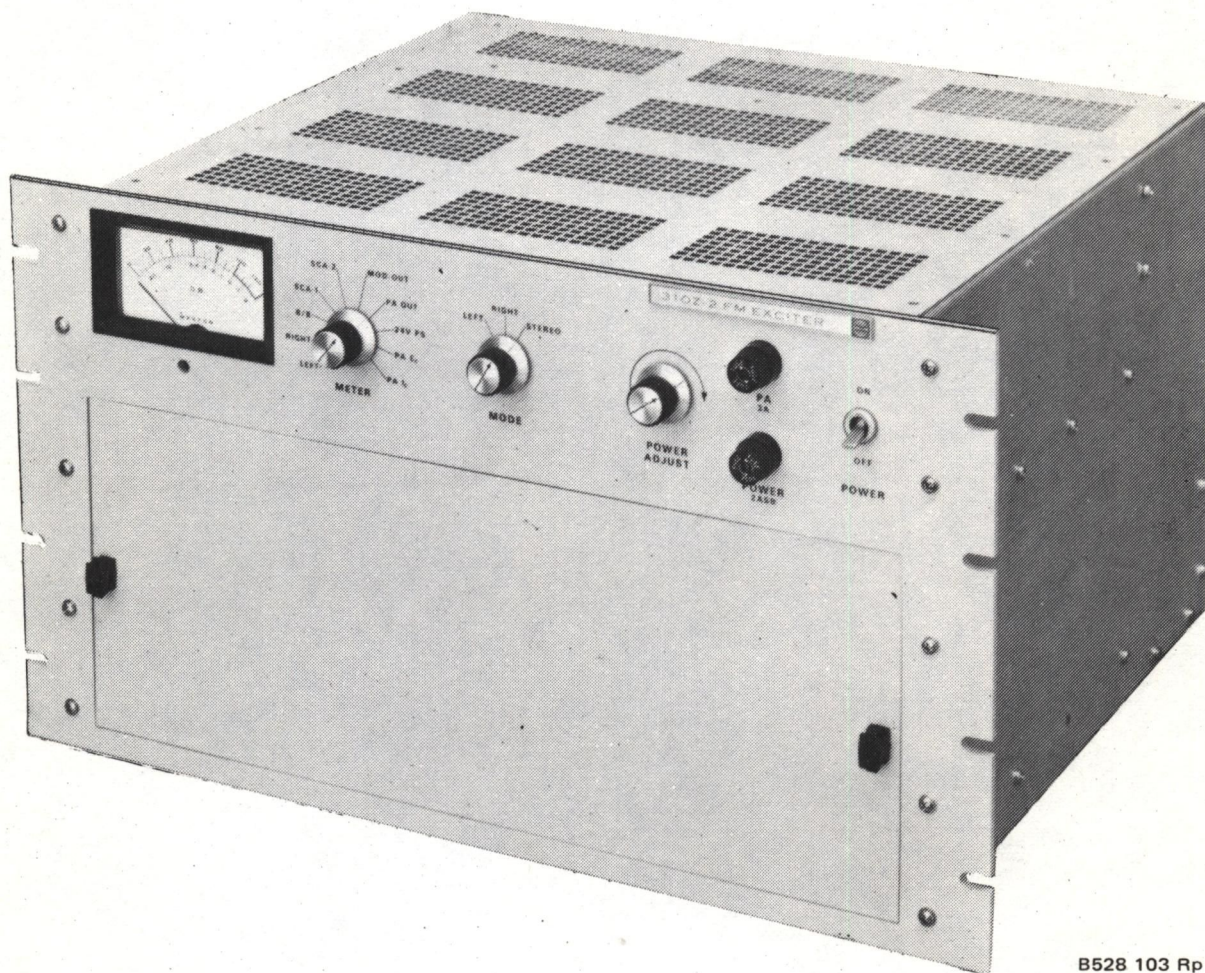

B528 103 Rp

Figure 1-1. 310Z-2 FM Broadcast Exciter.

1.1 INTRODUCTION

The solid-state 310Z-2 FM broadcast exciter (figure 1-1) provides a frequency-modulated signal in the 88- to 108-MHz range (exact frequency as specified by the customer) for further amplification and transmission. The exciter can be adjusted manually to provide maximum output of 20 watts and is prewired to accept three optional plug-in modules. The optional 786W-1 SCA Generators enable background music to be transmitted at either 41 kHz or 67 kHz multiplexed on an FM broadcast. The optional 786V-1 Stereo Generator allows broadcasting compatible time-division multiplex stereo. In addition, the optional 785E-1 STL (studio transmitter link) Interface Card can be substituted for the 786V-1 Stereo Generator to interface the 310Z-2 with common composite STL systems or other systems requiring an external baseband input to the modulator.

1.2 PHYSICAL DESCRIPTION

The 310Z-2 exciter is 483 mm (19 in.) wide, 267 mm (10.5 in.) high, and 381 mm (15 in.) deep, weighs approximately 18 kg (40 lb) and is designed for mounting a standard 483-mm (19-in.) equipment rack. Controls and power supply components are mounted on the chassis. A card cage secured to the chassis provides receptacles for the five plug-in circuit cards that contain most of the circuits. A removable front panel provides access to the cards. Connectors for the rf signal output and for the ac power input as well as the terminal strip for audio inputs are located on the back of the exciter. Built-in shielding prevents radiation and interference.

1.3 FUNCTIONAL DESCRIPTION

The functional units of the 310Z-2 FM Exciter are an FM modulator and an rf amplifier. In addition, a stereo generator and one or two sca (subsidiary communication authorization) generators are optional units that may be included as part of the 310Z-2. Each of these major functional units is constructed as a plug-in module, and the 310Z-2 is prewired so that the stereo generator and the sca generator plug-in modules can be added at any time.

When the 310Z-2 is used only for monaural broadcasts (without the optional sca generators or stereo generator), the audio input is applied to the baseband input of the FM modulator through the required audio processing circuits. A carrier frequency oscillator is modulated to full deviation by the input. This FM signal is also applied to the AFC system, which maintains the oscillator output frequency at carrier frequency.

When the stereo generator is used, the exciter functions the same as described above with the exception that left and right audio inputs are applied to the stereo generator through separate preemphasis networks. These audio signals are multiplexed to provide the baseband signal, which is filtered and applied to the FM modulator. When an sca generator is used, the sca audio input is amplified and used to frequency-modulate a 41- or 67-kHz subcarrier oscillator. The FM sca output is filtered and applied to the FM modulator.

general description

1.4 OPTIONAL EQUIPMENT

The 786V-1 Stereo Generator, 785E-1 STL Interface Card, and 786W-1 SCA Generators are customer options. Table 1-1 lists several 310Z-2 FM exciter features and indicates optional modules or cards required for each feature.

1.5 TECHNICAL CHARACTERISTICS

The technical characteristics for the 310Z-2 are listed below, and have been divided into five groups: (1) generator characteristics that apply to all 310Z-2 exciters, (2) those characteristics that apply to the 310Z-2 when it is used for monaural FM, (3) those characteristics that apply to the 310Z-2 when it is used for stereo FM with the 786V-1 Stereo Generator, (4) those characteristics that apply to the 310Z-2 when it is used for sca transmission with the 786W-1 SCA Generator, and (5) those characteristics that apply to the 310Z-2 when it is used for composite stereo STL transmission with the 785E-1 STL Interface Card.

1.5.1 General

Ambient Temperature Range:	0° to 55°C (32° to 131°F)
Ambient Humidity Range:	Up to 95%
Maximum Altitude:	2300 m (7500 ft)
Input Power Requirement:	117/234 volts ac, ±10%, single-phase, 50/60 Hz
RF Power Output:	0 to 20 watts
Output Impedance:	50 to 70 ohms, unbalanced
Output Frequency Range:	88 to 108 MHz, crystal-controlled (crystal installed and exciter adjusted at factory to meet customer requirement)
Carrier Frequency Stability:	Within ±500 Hz with ac line voltage of ±10% and temperature range of 0° to +55°C (32° to 131°F)
Harmonic and Spurious Radiation:	<p>Any emission appearing on a frequency removed from the carrier by between 120 and 240 kHz is attenuated at least 30 dB below the level of the unmodulated carrier.</p> <p>Any emission appearing on a frequency removed from the carrier by more than 240 kHz up to and including 600 kHz is attenuated at least 35 dB below the level of the unmodulated carrier.</p> <p>Any emission appearing on a frequency removed from the carrier by more than 600 kHz is attenuated at least 80 dB below the level of the unmodulated carrier, with the exception of harmonics of the rf carrier.</p>

Table 1-1. 310Z-2 FM Exciter Special Features and Customer Options.

FEATURE	OPTIONAL MODULES OR CARDS REQUIRED		
	786V-1 STEREO GENERATOR	785E-1 STL INTERFACE CARD	786W-1 SCA GENERATOR(S)
Monaural broadcasting (no options required)			
Monaural broadcasting with sca			X
Stereo broadcasting	X		
Stereo broadcasting with sca	X		X
Composite STL		X	
Composite STL with sca		X	X

Type of Modulation: Direct frequency modulation

Modulating Frequencies: 20 Hz to 100 kHz

FM Noise Level: 65 dB below 100% modulation

AM Noise Level: 55 dB below carrier level

1.5.2 Monaural FM

Audio Input Impedance: 600 ohms balanced

Audio Input Levels:

Monaural +10 ±2 dB mW for 100% modulation

SCA -10 to +15 dB mW adjustable from 0% to 10% modulation

Frequency Response: Standard 75-microsecond preemphasis; others optional

Distortion: Not more than 0.25% thd (total harmonic distortion)
Not more than 0.25% imd (intermodulation distortion)

general description

1.5.3 Stereo FM With 786V-1

Audio Input Impedance:	600 ohms balanced
Audio Input Levels:	+10 \pm 2 dB mW for 100% modulation
Frequency Response:	Standard 75-microsecond preemphasis for both right and left channels; others optional
Distortion:	Not more than 0.5% thd for 50-Hz to 15-kHz audio modulation, Not more than 0.5% imd
Stereophonic Subcarrier and Pilot Carrier Phasing:	Phase difference between the stereophonic subcarrier and pilot carrier is within the limits required for channel separation of more than 35 dB with audio-modulating frequencies of 50 Hz to 15 kHz.
Stereo Channel Separation:	At least 35 dB, 50 Hz to 15 kHz
Crosstalk:	At least 45 dB below either single-channel level
38-kHz Stereo Subcarrier Suppression:	45 dB below 90% modulation of the main carrier
Pilot Carrier Frequency:	19 kHz \pm 2 Hz
Pilot Carrier Level:	Adjustable from 0% to 12% modulation of main carrier

1.5.4 SCA FM With 786W-1

Audio Input Impedance:	600 ohms, balanced
Audio Input Level:	-10 to +15 dB mW, adjustable from 0% to 10% modulation
SCA Subcarrier Center Frequency:	67 kHz or 41 kHz
SCA Frequency Modulation of Main Carrier:	Adjustable from 0% to 30%
SCA Generator Center Frequency Stability:	Within \pm 0.5%
Frequency Response:	Standard 75-microsecond preemphasis

FM Noise Level: Less than -55 dB

Distortion: 1.0% for 50 Hz to 5 kHz with 3.5-kHz deviation
2.0% for 50 Hz to 5 kHz with 7.5-kHz deviation

Crosstalk: Crosstalk from main channel and stereo sub-channel into the sca channel shall be 50 dB below 10% modulation of the main channel. Reference: 4.0-kHz sca deviation.

1.5.5 Composite Stereo STL With 785E-1

External Baseband Input: 3.5 V p-p into 4700 ohms when used with 785E-1
STL Interface Card

External Telemetry Input: 1 V rms 20 to 30 Hz, when used with 786W-1 SCA Generator

2.1 GENERAL

Remove all packing material carefully. Check equipment against shipping invoices and records. Inspect the unit for damaged or missing components. Check for free movement of front panel controls. Any claims for damage should be filed promptly with the transportation agency. If such claims are to be filed, all packing material must be retained. Store the factory shipping container for future use.

2.2 PREINSTALLATION

Make sure that all plug-in filters and cards are securely plugged in. Refer to Section 6, Parts List for locations.

NOTE

If the 786V-1 Stereo Generator is not to be installed, filter FL1 is not required.

2.3 WIRING

2.3.1 Audio Input Connections

Use only balanced 600-ohm audio inputs to the 310Z-2. Use only twisted, shielded parts for input cables. (See figure 2-1.)

- a. Monaural Inputs - Connect the monaural audio input line to TB1-1 and TB1-3. Connect the cable shield to TB1-2. (See figure 2-1.)
- b. Stereophonic Inputs - Connect the left channel audio input line to TB1-1 and TB1-3. (See figure 2-1.) Connect the cable shield to TB1-2. Connect the right channel audio input line to TB1-4 and TB1-6. Connect the cable shield to TB1-5. Be sure that the 786V-1 Stereo Generator is plugged into the 310Z-2.
- c. SCA Inputs - Connect the SCA-1 (41-kHz) audio input to TB1-7 and TB1-9. Connect the cable shield to TB1-8. Connect the SCA-2 (67-kHz) audio input to TB1-10 and TB1-12. Connect the cable shield to TB1-11. Be sure that the 786W-1 SCA Generator is plugged into the 310Z-2. Set the 786W-1 METER switch to 3.5 kHz or 7.5 kHz, depending on the deviation to be used. Set the 786W-1 MUTE ENABLE switch to ON.
- d. Composite STL Input - Connect the output of the STL receiver to B/B IN jack J2 on the rear of the exciter. This connection should be made with RG-58A/U or RG-223 coaxial cable. Check to see that the 785E-1 STL card is installed in the A3 card position and that filter FL1 is removed from its socket.

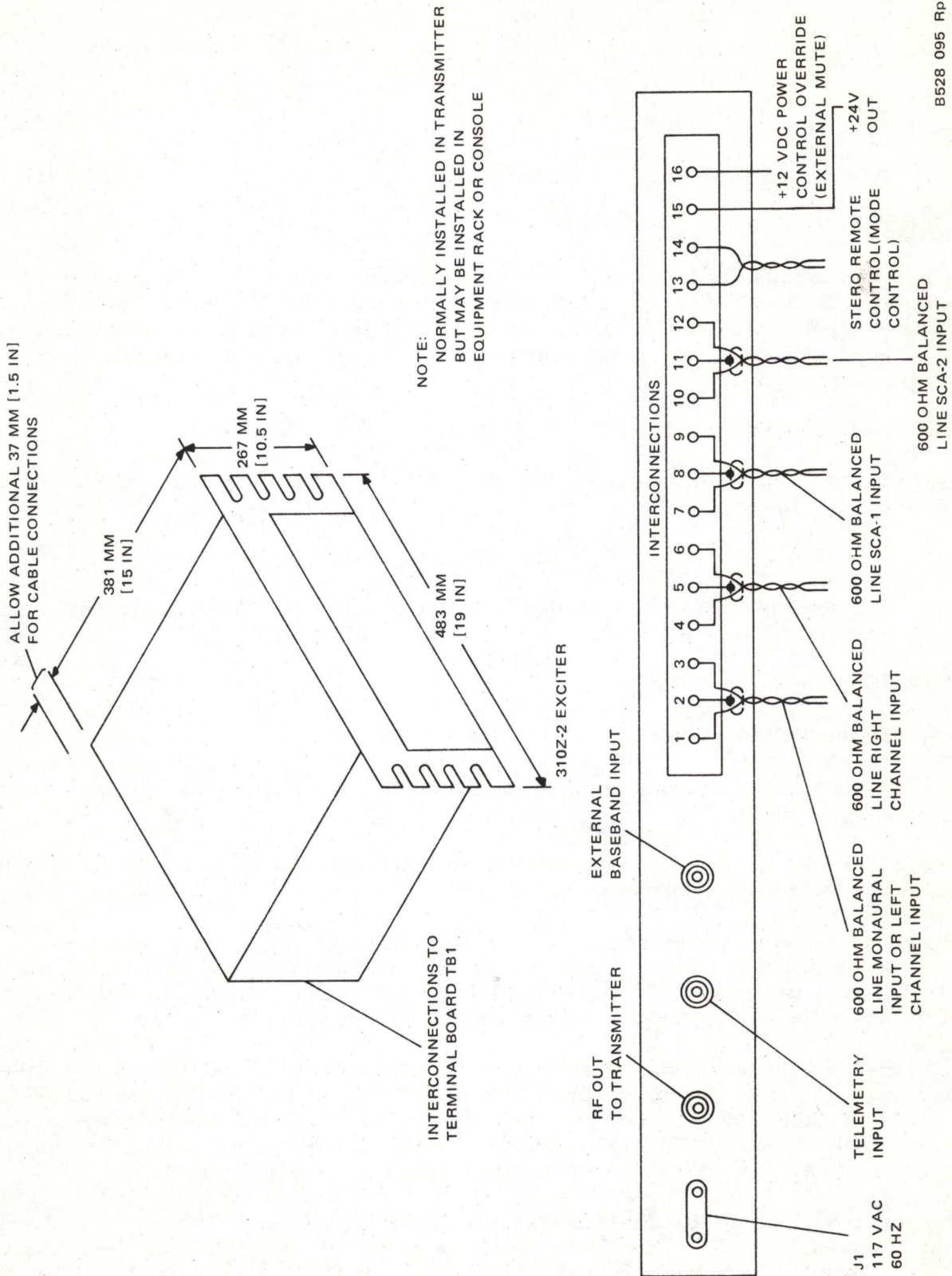

Figure 2-1. 310Z-2 FM Exciter, Outline Dimensions and Installation Details.

- e. Radio Remote Control Telemetry Input - Connect the telemetry output of the remote control unit to TELE IN jack J3 on the rear of the exciter. This connection should be made with RG-58A/U or RG-223 coaxial cable. Check to see that a 67-kHz 786V-1 SCA Generator is installed in the A2 card position.

2.3.2 Stereo Remote Control

If stereo remote control is desired, connect the leads from the station remote control system to TB1-13 and TB1-14 (ground). A normally closed contact must be provided for stereo operation.

2.3.3 RF Output

Connect a coaxial cable from the transmitter rf input to the exciter RF OUT jack, J1.

2.3.4 Input Power

Connect the ac line cord between P1 on the exciter and 117 volts ac.

CAUTION

Do not operate the 310Z-2 exciter without a load connected to the rf output, and do not operate the exciter over any extended period of time into a vswr greater than 2:1. To guard against such operation, steps should be taken during installation, as outlined in paragraph 2.3.5.

2.3.5 Power Control Override

A dc voltage source (+12 volts) should be connected to TB1-16 to protect the exciter output transistors when no plate voltage is present in the transmitter. This dc voltage is applied to the power regulator card to reduce the exciter output power to a safe level.

If the override voltage is not available directly from the transmitter with which the exciter is being used, the voltage provided at TB1-15 of the exciter may be connected through a relay so that it is applied whenever plate voltage is removed from the power amplifier stage in the transmitter.

2.4 INITIAL CHECKS

The 310Z-2 exciter is carefully adjusted and inspected at the factory and no special tests or adjustments are required upon installation. However, once the exciter has been installed, the transmitter should be checked to ensure that it is operating properly.

2.5 OUTPUT FREQUENCY CHANGE

The output frequency of the 310Z-2 is crystal controlled and can be changed to any desired frequency between 88 and 108 MHz. To change the exciter frequency, refer to paragraph 5.8.

3.1 GENERAL

Only the three front panel switches and the meter on the front panel of the exciter are used during normal operation. Refer to figure 3-1 for control and indicator locations and to table 3-1 for control and indicator descriptions. After the exciter has been placed in operation, it is necessary only to check meter indications (table 3-2) from time to time to ensure that the exciter is operating properly.

3.2 NORMAL TURN-ON PROCEDURE

- a. Place POWER switch to ON.
- b. Set MODE switch to LEFT, RIGHT, or STEREO, depending on the type of modulation desired.

3.3 ALTERNATE TURN-ON PROCEDURE

When the 310Z-2 is used in a Collins transmitter that has automatic-sequencing circuits, the POWER switch is normally left in the ON position and the exciter is turned on and off by the power-sequencing circuits of the transmitter.

3.4 STEREO/MONAUURAL REMOTE SWITCHING

When it is desired to switch the exciter from monaural to stereo from a remote location, a stereo on/off switch is connected between pins 13 and 14 of terminal board TB1. This switch will then control relay K1 so that remote switching can be used as long as the MODE switch is in either the LEFT or RIGHT position. The STEREO position overrides the remote stereo OFF position. The selected LEFT or RIGHT line will then serve as a feed for monaural operation.

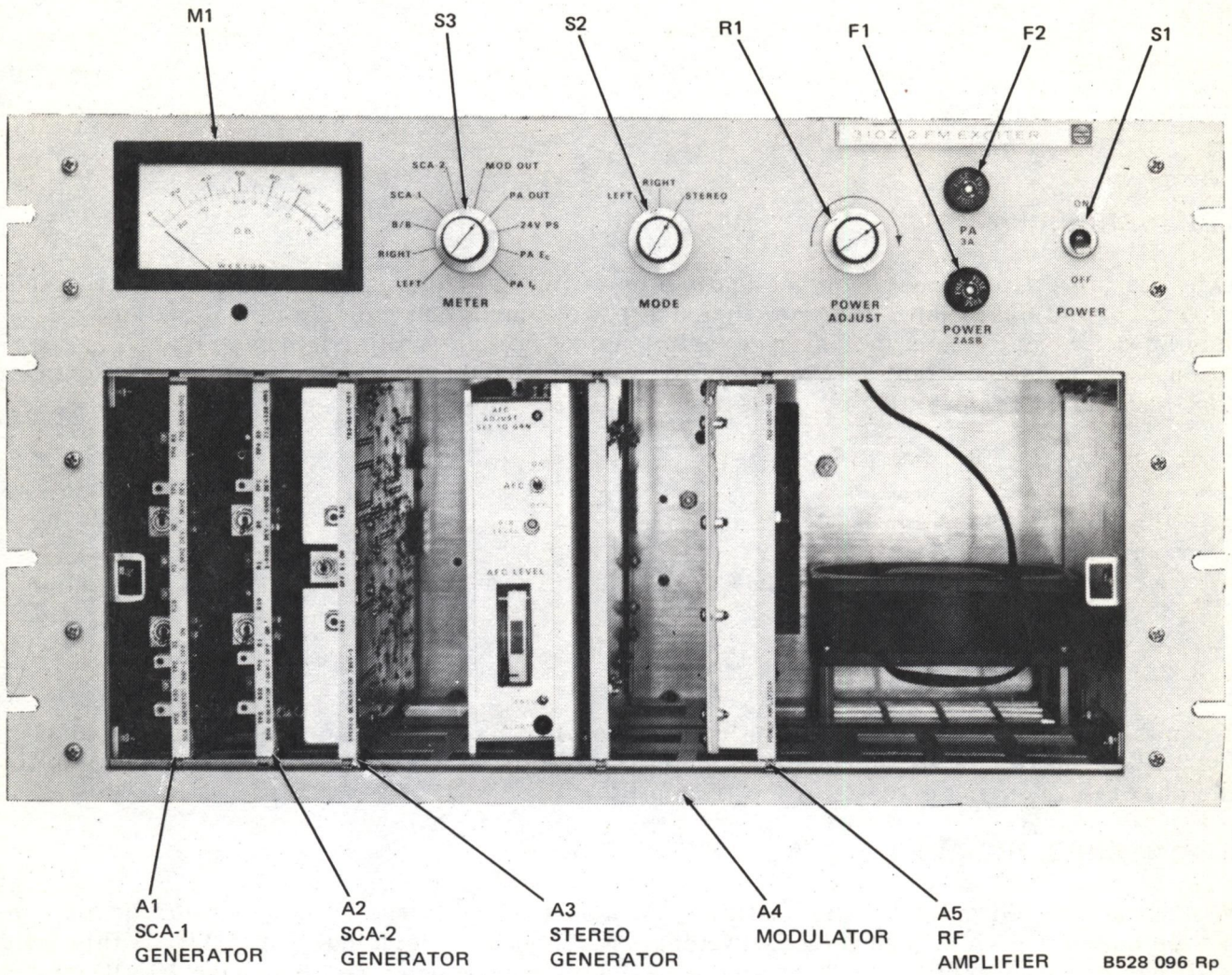

Figure 3-1. 310Z-2 FM Exciter, Front Panel Controls and Indicators.

Table 3-1. 310Z-2 FM Broadcast Exciter, Front Panel Controls and Indicators.

REF DES	CONTROL OR INDICATOR	FUNCTION
S1	POWER	Controls the application of primary power to the exciter.
S2	MODE	Selects either the left audio input to be broadcast monaurally (LEFT), or the right audio input to be broadcast monaurally (RIGHT), or the left and right audio inputs to be broadcast stereophonically (STEREO).
S3, M1	METER	Meter M1, in conjunction with function switch S3, permits monitoring of the various audio inputs and dc parameters from the 310Z-2 exciter. Refer to table 3-2.
R1	POWER ADJUST	Adjusts power output of exciter.

Table 3-2. Test Meter Indications

POSITION OF METER SWITCH S3	FUNCTION	METER INDICATION
LEFT	Left channel modulation	Semi-peak reading meter responds to peak audio level in manner similar to modulation monitor.
RIGHT	Right channel modulation	Same
B/B	Baseband output of stereo generator	Same
SCA-1	41-kHz sca modulation	Calibration at 100% determined by setting of S2 on 786W-1 in A1 card position.
SCA-2	67-kHz sca modulation	Same as SCA-1 except card A2
MOD OUT	Modulator rf output	Relative rf output of modulator. Reads 50% to 100% as noted on individual data sheet.

Table 3-2. Test Meter Indications (Cont).

POSITION OF METER SWITCH S3	FUNCTION	METER INDICATION
PA OUT	Power amplifier rf output	Relative rf output of power amplifier. Calibration controlled by R2 on 310Z-2 main frame. Set for 100% under normal power output and load conditions.
24V PS	Output of fixed power supplies of main frame	Reads combined output of fixed 24-volt power supplies. Normally reads 85% to 115%. Reads 40% to 60% when either supply inoperative.
PA Ec	Power amplifier collector voltage	Reads relative collector voltage to driver and power amplifier transistors. Consult data sheet for normal readings.
PA Ic	Power amplifier collector current	Reads relative collector current to driver and power amplifier transistors. Consult data sheet for normal readings.

4.1 GENERAL

The 310Z-2 exciter produces a frequency-modulated output for driving a power amplifier in an FM broadcast transmitter. The 310Z-2 employs the direct method of frequency modulation. The optional 786V-1 Stereo Generator produces signals that meet all FCC requirements for stereophonic broadcasting. The optional 786W-1 SCA Generator produces an FM subcarrier for broadcasting background music under an FCC Subsidiary Communications Authorization.

4.2 BLOCK DIAGRAM DISCUSSION

Refer to figure 4-1 (simplified block diagram), figure 7-1 (detail block diagram), and figure 7-2 (main frame schematic) during the following discussion. The major circuits of the 310Z-2 are contained on plug-in modules; and as shown on figure 4-1, these modules are the major blocks of the 310Z-2 exciter. When an exciter is used for monaural broadcasting without the optional modules, the monaural input is normally applied to the audio-processing circuits and then directly to the modulator module as the baseband signal. Since the remaining circuits operate the same for either monaural or stereophonic and sca broadcasting, the block diagram discussion covers a complete exciter with the optional modules.

The left and right audio input signals are applied through the audio frequency circuits as the modulation input to the balanced modulator of the stereo generator. These signals modulate two 38-kHz subcarrier signals that are 180° out of phase. As a result, the 38-kHz carrier is canceled so that the modulator output consists of only the two modulation frequencies and the desired modulation sidebands of the carrier frequency. One component is directly proportional to the sum of the two audio signals (L + R), and the other component is a double-sideband signal (L - R). The output from the balanced modulator is combined with the 19-kHz pilot carrier. Signal generation within the stereo generator is described in paragraph 4.3.

The output from the stereo generator is passed through a 53-kHz low-pass filter and then combined with the output from the sca generator (if used) to produce the baseband signal. The 19-kHz pilot carrier is derived in the stereo generator by routing one of the 38-kHz subcarrier signals to a divide-by-2 circuit to produce the 19-kHz pilot carrier, which is phase-locked to the 38-kHz signals. The baseband signal is then applied to the modulator.

The sca audio inputs are applied to an audio transformer in the sca generators, routed through a preemphasis network, amplified, and used to frequency-modulate the carrier frequency of the subcarrier. The audio input is also monitored by a carrier mute circuit, which removes the sca output whenever the audio input drops below the selected mute level.

4.3 STEREO GENERATOR A2

The 786V-1 Stereo Generator performs the conversion of stereophonic input signals to an output that conforms to the standards approved by the FCC for transmission of stereophonic signals. To provide a realistic stereo effect, the 786V-1 maintains the difference in time delay and signal amplitude from the sound source to both the right and left channel microphones through the entire stereo system. Channel separation, which is the isolation between the two channels, is held to greater than 35 dB by the 786V-1 to enhance the stereo effect to the listener. The following paragraphs discuss stereophonic signal generation and the principles of operation of the 786V-1 Stereo Generator. Refer to figure 7-4 for a schematic diagram of the 786V-1 Stereo Generator.

4.3.1 Signals Required

The FCC requires that stereophonic FM broadcast signals be compatible, which means that the signals may be detected by either a monophonic or stereophonic receiver. To satisfy this and other requirements of the FCC, the signals and frequencies generated must be as shown in figure 4-2. In monophonic receivers only, the L + R (left plus right) audio frequency component of the signal, called the main channel, is used. The L - R (left minus right) component of the baseband signal, called the subchannel, is a difference signal only and is composed of sidebands of a 38-kHz suppressed subcarrier. This difference component and the 19-kHz pilot carrier signal are reduced by the deemphasis network of the monophonic receiver.

In FM stereophonic receivers, all signals shown in figure 4-2 are detected and used. The L - R subchannel and L + R main channel signals are mixed, added, and subtracted to separate them into left and right audio signals. The 19-kHz pilot carrier signal is doubled in the receiver to regenerate the 38-kHz suppressed subcarrier, which is used to demodulate the stereo signal. By this means, proper phase relationship is maintained between main channel and subchannel frequencies and between the left and right audio channels.

After the L + R and L - R signals have been generated, any interaction or exchange of information between the main channel (L + R) and the subchannel (L - R) represents crosstalk, which deteriorates the signals and has the effect of adding noise. In stereo transmitting systems, crosstalk must be kept at least 40 dB below either signal-channel level.

To maintain 30-dB channel separation, as required by the FCC, for the condition of an input into one channel only, the main channel and stereo subchannel signals must have equal peak amplitude, within approximately 0.3 dB, and the envelope of the subchannel signal must cross the zero level simultaneously with the main channel signal, within approximately $\pm 3^\circ$.

4.3.2 Method of Signal Generation in 786V-1 Stereo Generator

The 786V-1 generates the spectrum of signals shown in figure 4-2 by the time-division multiplex method. The basic system operating principle is shown in figure 4-3. The left and right audio channels are switched into the link (used alternately) at a 38-kHz rate. If the receiver switching rate is synchronized with the transmitter switching rate, the original left and right audio signals are detected. In the receiver the frequency of the 19-kHz pilot carrier is doubled to synchronize the receiver to the transmitter. It is important that the switching frequency in both the stereo generator and the receiver be of the same phase to retain the identity of the left and right audio signals. In the 786V-1 generator

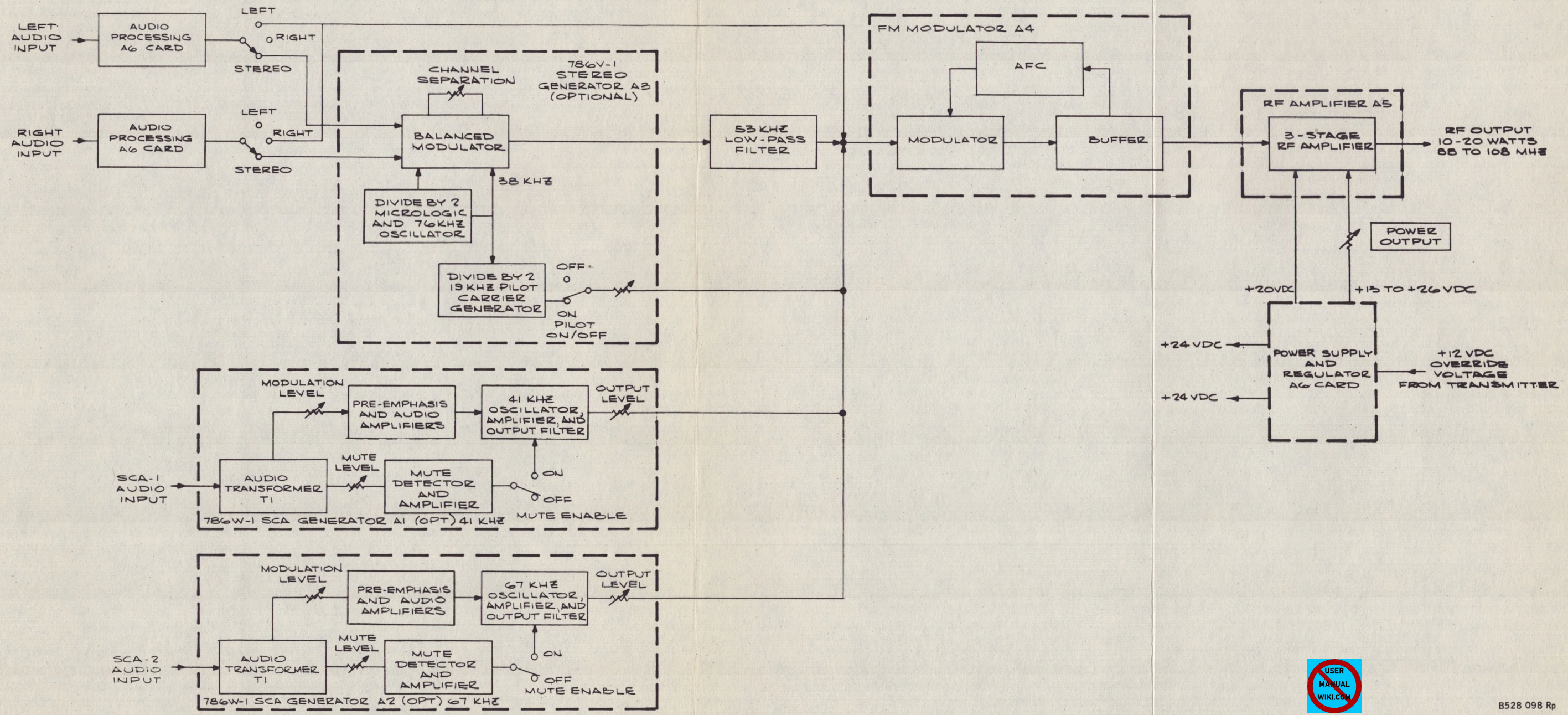

B528 098 Rp

If You Didn't Get This From My Site,
Then It Was Stolen From....
www.SteamPoweredRadio.com

Figure 4-1. 310Z-2 FM Exciter, Simplified Block Diagram.

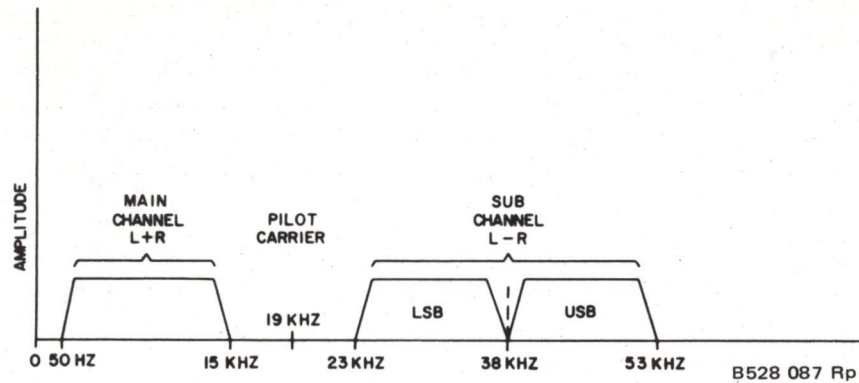

Figure 4-2. Spectrum of Signals in Stereo Baseband Audio.

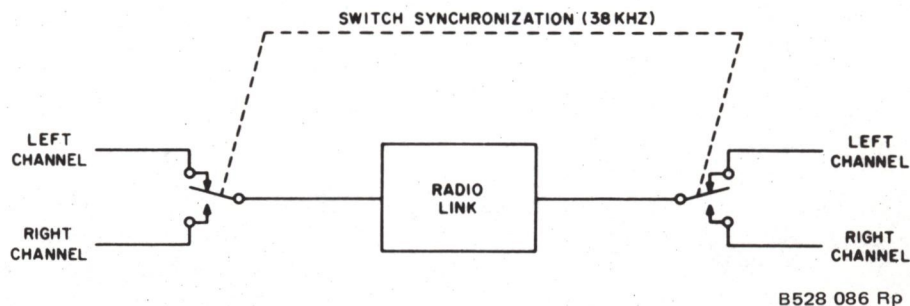

Figure 4-3. Elementary Time-Division Multiplex System.

a crystal-controlled oscillator is used to generate a 76-kHz signal. This 76-kHz signal is divided by 2 in a micrologic flip-flop circuit; and by using both the logic 1 and the logic 0 outputs of the flip-flop, two 38-kHz square waves are obtained that will be exactly 180° out of phase. One of the 38-kHz square-wave signals is used to trigger another micrologic flip-flop (A4) to obtain a phase-locked 19-kHz pilot carrier signal.

To generate the baseband stereo signals, the 786V-1 Stereo Generator utilizes the basic circuits and functions of a balanced modulator. Refer to figure 4-1, the exciter block diagram, for component relationship and signal flow; refer to figure 7-4, the stereo generator schematic, for circuit detail. Although transistors Q2 and Q5 and their associated circuits function as a balanced modulator, several additional considerations affect the overall operation of the circuits to produce the desired stereo output signal. Separate input channels couple the two different modulating audio signals, L and R (left and right), to the modulator. Emitter follower Q1 applies the right audio signal to the balanced modulator, and emitter follower Q4 couples the left audio signal to the balanced modulator. The 38-kHz subcarrier signals are applied to the balanced modulator transistor switches, Q3 and Q6. Because the two 38-kHz signals are of opposite phase, modulator transistors Q2 and Q5 are switched on and off at 38 kHz. Furthermore, when the outputs from Q2 and Q5 are combined, the subcarrier signals cancel and the 38-kHz subcarrier does not appear in the

output signal. Transistor Q2 conducts during one half-cycle of the subcarrier frequency, and during this half-cycle one excursion of the square wave is modulated by the audio signal in the right channel. During the next half-cycle of the subcarrier, Q5 conducts and the next excursion of the square wave is modulated by the audio signal in the left channel. As stated previously, the 38-kHz subcarrier signals are balanced out in the modulator, and only the two modulating audio frequencies and the desired modulation sidebands of the carrier frequency are combined in the output.

4.3.3 Analysis of Signals Generated

If it can be demonstrated by mathematical analysis that if a square wave is modulated alternately by two audio signals, two significant components are in the resultant signal. One component is directly proportional to the sum of the two audio signals ($L + R$), and the other component is a double-sideband (DSB) signal centered on the switching frequency or subcarrier frequency (38 kHz). Mathematical analysis in detail is hardly within the scope of this manual. One other fact derived from such analysis is necessary, however, to an understanding of the 786V-1 operation. Because the peak amplitude of the fundamental sine-wave components of a square wave is $4/\pi$ times the peak amplitude of the square wave itself, the $L - R$ component mentioned above is $4/\pi$ times the $L + R$ component.

To make $L + R = L - R$, as required by the FCC, small portions of the L and R signals are added directly in the 786V-1, shunted around the balanced modulator through R9, R25, R16, and C13, and added to the modulator output.

Development of the FCC required signal in the 786V-1 may also be demonstrated by an analysis of the waveforms generated. Figure 4-4 represents the circuit operation when the inputs to each of the audio channels (L and R) are identical sine waves. On one half-cycle of the square-wave switching frequency (subcarrier frequency), Q5 conducts and the L signal is utilized (or sampled). On the next half-cycle, Q2 conducts and the R signal is utilized. Expressing the same action in a different way, on one half-cycle of the switching frequency an excursion of the subcarrier square wave is modulated by the left channel audio signal; and on the next half-cycle the next excursion of the subcarrier square wave is modulated by the right channel audio signal. As may be seen in figure 4-4, the 38-kHz subcarrier switching frequency is balanced out, and with equal sinewave input to both audio channels ($L - R = \text{sine wave}$) no sidebands are generated. The spikes shown on the composite sine wave in the third illustration of figure 4-4 are caused by imperfect switching and must be filtered out. The output of the modulator is then a sine wave identical to the original sine-wave input in either channel ($L - R$ or $[L + R]/2$). Equal sine-wave input seldom occurs in an actual broadcast but is shown here for analysis.

Figure 4-5 shows the balanced modulator output when $L = 1$ and $R = 0$. The output of the balanced modulator is an audio component plus DSB components centered on the switching frequency, and odd harmonics. When the odd harmonics are filtered out by a phase-linear low-pass filter, the third waveform results. The audio component is then increased by $4/\pi$ and the fourth illustration results.

Figure 4-6 shows the time-division multiplex signal when $L = -R$, or $L + R = 0$, and $L - R = 2L$ (or $2R$). The composite waveform from the balanced modulator is shown in the third illustration. This waveform is composed of equal but opposite audio components, DSB components centered on the switching frequency, and odd harmonics. The audio components balance out; and when the odd harmonics are removed by filtering, the waveform in the fourth illustration results. This waveform is a DSB signal, which equals $L - R$ as required.

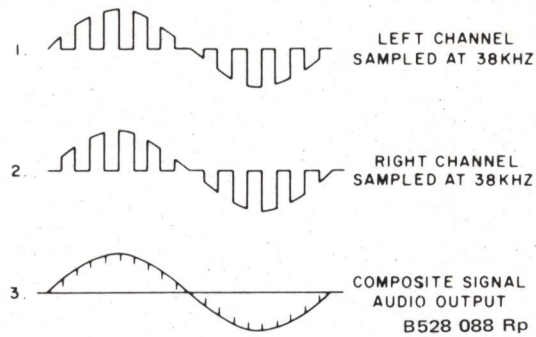

Figure 4-4. Balanced Modulator Output When $L + R = 2$; $L - R = 0$.

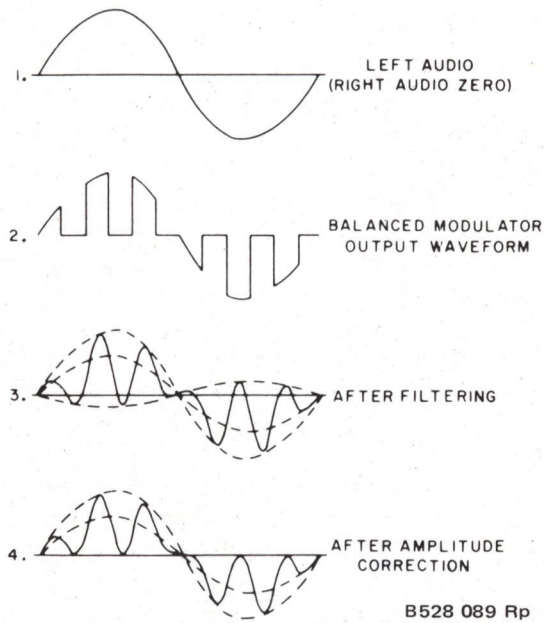

Figure 4-5. Balanced Modulator Output When $L + R = 1$; $L - R = 1$.

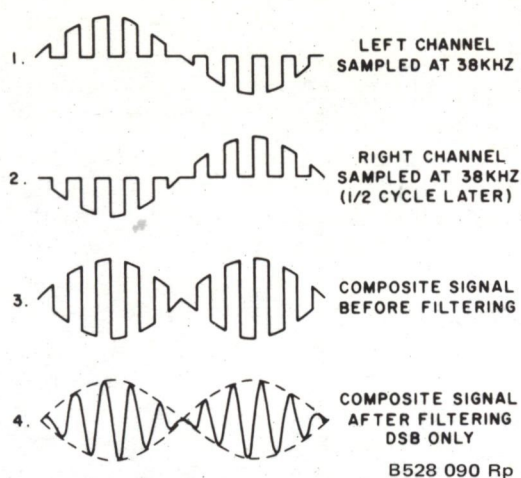

Figure 4-6. Balanced Modulator Output When $L + R = 0$; $L - R = 2$.

Perhaps the relationship of the $L + R$ and $L - R$ signals should be noted again here in connection with the above analysis. The $L + R$ main channel component of the composite signal represents the sound that would be heard if only one microphone is used for input, and it is also the sound that would be heard from a microphonic receiver tuned to a stereo broadcast. The $L - R$ component is a difference signal only. It may be a positive value, may be equal to zero, or may be a negative value (in the case where R is greater than L). When the composite signal is detected in a stereo receiver that is exactly synchronized with the transmitter, the $L + R$ component is split and routed to both left and right audio channels in the receiver. The $L - R$ difference signal is split also, and in effect is added to the left channel audio component and subtracted from the right. The result is $(L + R)/2 + (L - R)/2 = L$ in the left channel, and $(L + R)/2 - (L - R)/2 = R$, in the right channel. In this way the receiver gives a perfect reproduction of the stereo input to the transmitter.

4.3.4 Circuit Analysis

Both left and right audio signals are fed through preemphasis networks in the exciter before application to the right and left audio inputs of the stereo generator, connector pins 13 and 29, (figure 7-4). Within the generator the left and right audio channels are identical. The audio signals are fed through 15-kHz low-pass filters (FL1 and FL2), which sharply attenuate frequencies above 15 kHz. From FL1, capacitor C1 couples the right audio signal to the base of emitter follower Q1 and then to the modulator at the junction of resistors R9 and R10. The right channel audio signal is divided so that the signal through R9 adds to the left channel signal and the signal through R10 modulates the 38-kHz subcarrier. A similar circuit couples the left audio signal to emitter follower Q6 and to the other side of the balanced modulator at the junction of resistors R25 and R26. The signal through R25 adds to the right channel signal (through R9) and is routed around the modulator to increase the $L + R$ component of the modulator output. Variable resistor R16 provides a control for the amplitude of the $L + R$ component to control channel separation.

The 38-kHz subcarrier signals for the balanced modulator are produced from the output of the 76-kHz oscillator, transistor Q7 and its associated circuits. The oscillator frequency is controlled by crystal Y1, and after amplification by amplifier Q8 the 76-kHz signal triggers a flip-flop (micrologic A1). By using both the logic 1 and the logic 0 from this flip-flop, two 38-kHz signals are obtained that are 180° apart in phase. The output signals from flip-flop A1 are first amplified by the inverters (micrologics A2 and A3) and then applied to the modulator through transistor switches Q3 and Q6. Capacitor C26 helps maintain balance between Q3 and Q6 and improves the switching operation. The 38-kHz signals combine with the right and left channel audio signals at the base of Q2 and Q5 respectively. As a result, Q2 and Q5 alternately conduct at a 38-kHz rate and produce the stereo signals, which are coupled through C12. The 38-kHz output from micrologic inverter A3 triggers micrologic flip-flop A4. With both the set side (pin 1) and the reset side (pin 3) of the flip-flop grounded, the flip-flop functions as a complementary flip-flop. Thus, the output from the logic 1 side (pin 7) is a 19-kHz signal that is phase-locked to the 38-kHz subcarrier signals. The 19-kHz pilot carrier signal is routed through the PILOT CARRIER switch (S1) to a filter network (C29, C23, L2, and C24), which removes the undesired third harmonic of 19 kHz. From the filter the signal is fed through potentiometer R49, which provides control of the pilot carrier amplitude, through capacitor C14 and a resistor network to the output of the balanced modulator.

Bypass capacitors C25 and C4 provide an ac ground for any signal through Q3 when the transistor conducts. Similar capacitors (C27 and C11) perform the same function in relation to Q6. Potentiometers R12 and R28 provide a means for adjusting the sideband suppression. Of special importance in this circuit is suppression of the 76-kHz harmonics of the 38-kHz subcarrier. The L - R double-sideband signal from the balanced modulator and the 19-kHz pilot carrier signal are combined, and capacitor C12 couples the combined signal to the multiplex output, connector pin 16. The L + R amplitude correction (from R16 through C13) adds to the signal coupled through C12, to form the composite stereo baseband signal at the multiplex output.

4.4 SCA GENERATOR A1/A2

4.4.1 General

Signals from the 786W-1 SCA Generator become part of the audio baseband signal that is used to modulate the carrier. The subcarrier oscillator is a free-running multivibrator, which generates a 67-kHz center frequency that is frequency modulated by the sca audio input signal. During normal stereo broadcast operation, modulation is limited to ± 3.5 -kHz deviation to avoid interference with the stereo frequencies in the baseband signal. During monophonic broadcasts, ± 7.5 -kHz deviation is used. The modulation output from the oscillator is filtered to remove unwanted harmonics. Refer to figure 4-1, the exciter simplified block diagram, for component relationship and signal flow; refer to figure 7-3, sca generator schematic for circuit detail.

4.4.2 Circuit Analysis

The sca audio input is applied to the sca generator through connector pins 17 and 19 (figure 7-3). The main signal path is through T1 to audio amplifier Q2, but a portion of the input signal is also applied through S2 to the sca audio input of the vu meter, and through the mute level control (potentiometer R1) to the carrier mute circuits.

theory of operation

Modulation level control R3 selects the sca audio input level, which is coupled through C1 to impedance-matching emitter follower Q1. A standard 75-microsecond preemphasis network (consisting of R7, R8, and C3) and capacitor C4 couple the input signal to audio amplifier Q2. Capacitor C30 and switch S2 couple the amplified audio signal to the modulation input of the vu meter. Switch S2 selects the correct attenuation (R46 or R47) of the modulation input signal to provide a 0-vu indication for either 3.5-kHz or 7.5-kHz frequency deviation. The audio signal used to modulate the subcarrier frequency is applied through CR1 to the subcarrier oscillator circuit. Transistors Q4 through Q7 and their associated circuits comprise the astable multivibrator circuit that generates the 67-kHz center frequency subcarrier. Deviation of the subcarrier frequency, as adjusted by modulation level R3, is within the range selected (± 3.5 kHz or ± 7.5 kHz). The modulated rf output from the oscillator is coupled through C10 and R3 to the base of amplifier Q8.

The carrier mute circuit is connected to the collector circuit of amplifier Q8 through MUTE ENABLE switch S1. Whenever the carrier mute circuit is being used (normally) and the audio input level drops below the level selected by MUTE LEVEL control R1, the output from the sca generator is grounded at the collector of Q8. Positive pulses that are normally applied to the base of Q12 are removed, and Q12 is turned off. As a result, C27 charges through R43 toward +20 volts; and when a potential of +10 volts is reached (in 3 seconds), diode CR9 breaks down and a positive voltage is applied to the base of Q13. Consequently, the collector of Q13 is at ground potential and this ground is applied through S1 to the collector of Q8.

Assuming that the input level is greater than the threshold level selected by MUTE LEVEL control R1, the modulated signal from the subcarrier oscillator is amplified by the direct-coupled amplifier (Q8 and Q9) and applied through CR7, R32, and R51 to the filter network. Capacitors C12 through C21 and inductors L1 through L3 comprise a 2-section band-shaping filter that removes the unwanted harmonics of the 67-kHz subcarrier. Capacitor C22 couples the filtered signal to emitter follower Q10, which provides a low output impedance to feed the SCA subcarrier signal through capacitor C23 and connector pin 43 to the input of the FM modulator card of the exciter.

4.5 FM MODULATOR A4

The FM modulator is a direct FM modulator operating at carrier frequency. A phase-lock automatic frequency control system controls the output frequency within very tight tolerances. Refer to figure 7-5, modulator schematic, for circuit details.

Transistor Q1 is operated class A as a Clapp oscillator with inductor L5 as the oscillator tank coil. The frequency of oscillation is determined by L5 and the net capacitive reactance formed by CR3, CR4, CR5, CR6, C4, C15, C7, C8 and C9. Elements CR3, CR4, CR5 and CR6 are voltage-variable capacitors, or varicaps, whose terminal capacitance is an inverse function of applied voltage. Varicaps CR3 and CR4 are operated with a fixed dc bias as modulators. The bias is adjustable by R5 and is set for best linearity in final test. Varicaps CR5 and CR6 are operated with two independent bias voltages chosen in a manner such that the devices cannot be forward biased. The more positive of the two voltages is controlled by AFC ADJUST control R7 and is used as a fine frequency or phase adjustment for the modulator. The lower of the two voltages is derived from the phase detector loop filter or from a fixed dc voltage for test purposes.

The modulator circuits are temperature compensated by capacitors C7, C8 and C9 to reduce drift. Isolation from the load is enhanced by a T-pad consisting of resistors R18, R19, and R20. Buffer stage Q2 is operated at approximately 500 milliwatts. The collector circuit is coupled to the load through a Pi network consisting of L8, C24, and C25. A resistive pad consisting of R26, R27, and R28 further isolates load variations from the modulator circuits. An rf sample is derived from the buffer through C22, clipped by diodes CR10 and CR11, and then coupled to U1, a high-speed ECL (emitter-coupled logic) binary divider. The output of the divider is amplified and shaped in an amplifier composed of Q3, Q4 and associated circuits and applied to complementary-MOS divider U2. Divider U1 divides the carrier frequency input by a factor of 16 while divider U2 divides its input by 1024 for a total division of 16,384.

The reference crystal is enclosed in an oven at 75° centigrade and operates at 1/64 of carrier frequency. The reference oscillator is an untuned device consisting of integrated circuit U5 and associated components. A vernier frequency adjustment is included in the form of a screwdriver adjustment, C38, accessible from the front panel. The capacitor provides sufficient adjustment range to compensate for aging of the crystal.

The output of the oscillator is divided by a factor of 128 in divider U4 and further divided by a factor of 2 in one-half of divider U3. The other half of U3 is a simple flip-flop that acts as a phase detector. The device is clocked by the divided reference frequency signal at a rate 1/256th of the crystal frequency. The flip-flop is then reset by a narrow pulse derived from the divided modulator output signal. The large division ratio of the modulator divider effectively removes the phase shift associated with the frequency modulation process. The resultant phase deviation at the output of the divider is a very small fraction of the available phase detector range at the lowest modulating frequency of interest.

The output of phase detector U3B is a rectangular phase with a duty cycle that is a function of the time difference of the input clock and reset pulses; hence, a function of the phase angle between the modulator and reference oscillator zero crossings. This pulse is amplified by transistor Q7 and filtered by a network consisting of R53, R54, C33, and C34 to reject the comparison frequency and retain the dc component of the pulse. This dc voltage is displayed on meter M1 as an aid in initial setup and maintenance. A green band is shown on the meter as a recommended operating range, and the meter is set by the AFC ADJUST control R7, a front panel adjustment.

The dynamic characteristics of the loop are established by a loop filter consisting of R15, R16, C10, and C11. The time constants are chosen for best compromise between minimum lock acquisition time and minimum disturbance of low-frequency phase response of the modulator system.

If phase-lock is lost, the input frequencies to the phase detector will be unequal and a beat note will appear at the output of the detector. This beat note is ac coupled from amplifier Q8 to a 3.5-kHz low-pass filter and further amplified by amplifier Q9. A series of constant-amplitude pulses with a repetition rate proportional to the difference frequency appear at Q9 collector. These pulses are rectified and used to turn on transistor Q5, which activates ALARM lamp CR16 and turns off transistor switch Q6. Switch Q6 applies a dc bias to the power amplifier regulator, which squelches the exciter rf output, thus preventing off-frequency operation. A charging current is applied to the AFC loop filter causing capacitor C10 to charge to a value much greater than its normal value. Four-layer diode CR18 conducts when this charge reaches a certain value and discharges C10 to a value much lower

than its normal value. The charging current then slowly recharges C10 and sweeps the oscillator frequency through its normal operating frequency. When the correct frequency is reached, the loop is locked and the charging current is removed. At this time ALARM lamp CR16 is extinguished and the dc bias is removed from the pa power supply allowing normal operation to resume. This circuit allows much faster lock acquisition and more optimum loop time constants for the application to be employed.

Transistors Q10, Q11 and associated components are used to provide a "soft" turn-on and turnoff for the crystal oven heater to minimize transients in the modulator. The circuit is straight forward with Q10 operating as a current amplifier and Q11 operating as a saturated switch.

4.6 AUDIO/REGULATOR CARD A7

Audio preemphasis for both monaural and stereo operating modes is obtained from feedback shaping in a pair of high-gain, integrated circuit, operational amplifiers. Both channels are fed from balanced 600-ohm lines through H pads and transformers to eliminate effects of uneven source impedances. The left channel response is determined by components R57, R58, R59, R60, C20, C21, and C22. All are fixed low tolerance components. Right channel response is determined by similar components with the addition of three vernier elements R41, R45, and R42, which allow trimming overall gain, mid-frequency and high-frequency gain, respectively to permit matching of response of both channels to a very high degree. This is done to minimize linear crosstalk in the stereo mode, which results from uneven gain and phase tracking of the left and right channels.

Variable resistor R30 provides a vernier setting of monaural gain to permit matching that mode to stereo operation.

Relay K1 is included to permit selection of stereo or monaural operation either locally or by remote control.

4.7 785E-1 STL INTERFACE CARD A3

The 785E-1 STL Interface Card provides an interface between commonly used composite STL systems or other operating modes such as quadraphonic operation requiring an external baseband input to the modulator. The 785E-1 provides input processing and the necessary gain and phase linearity to accommodate these systems. Refer to figure 7-7. A bridging input of approximately 4700 ohms is provided in a differential input configuration to avoid any degradation of signal-to-noise ratio through ground loops. An adjustable common mode rejection control, R4, is provided to minimize hum. A high frequency phase adjustment, C7, is provided to compensate for minor phase degradation at high frequencies due to receiver and transmitter bandwidth limitation.

Integrated circuit U1 is a low-noise wideband operational amplifier connected as a balanced differential input amplifier. A complementary symmetry power booster stage composed of transistors Q1 and Q2 raises the load impedance to a value suitable for U1. An output pad consisting of R16 and R17 reduces the output level of the amplifier to approximately 200 mV required by the modulator. Capacitor C7 provides a minor phase adjustment at the high end of the spectrum to compensate for phase errors in the system.

4.8 RF AMPLIFIER A5

The rf amplifier card of the 310Z-2 contains a broadband, solid-state, 3-stage rf amplifier. The FM signal from the rf mixer is amplified to provide an rf output power level of 10 to 20 watts. Refer to figure 7-6 for circuit details.

The first amplifier stage (Q1, figure 7-6) receives the FM input signal (through jack J1) and operates as a class A amplifier, using 20-volt dc power supplied through filter FL1. The second and third stages (Q2 and Q3) operate as class C amplifiers so that greater efficiency is obtained. All three amplifier stages are set for gain saturation, which is permissible with an FM input signal and provides higher efficiency. Both Q2 and Q3 use a variable 10- to 26-volt dc power input through FL2. The rf output power level of the amplifier (adjustable from 10 to 20 watts) is controlled by the level of this variable dc power, which is adjustable by the POWER ADJUST control mounted on the front panel. The rf amplifier output is coupled through J2 to J1 on the exciter main chassis.

4.9 POWER SUPPLIES

Three power supplies are used in the 310Z-2 exciter. Two are fixed, regulated supplies capable of supplying 24 volts at approximately 700 mA each. One is a variable supply for the rf amplifier. The variable supply supplies up to 26 volts at approximately 2 amperes. All three power supplies are derived from a common, power transformer, rectifier, and filter system. Separate regulators are utilized for each function.

Regulators U1 and U2 are each fixed 24-volt 3-terminal regulators, which supply the basic exciter requirements. Regulator U1 supplies power to the audio and meter amplifier circuits, A1 card, and A4 card. Regulator U2 supplies power to the A2 card, A3 card, and the fixed voltage requirements of the A5 card.

Power for the driver and rf amplifier stages is supplied by an adjustable regulated power supply. This supply consists of an integrated circuit regulator (U2 on the A6 card) and associated components. The regulator supplies base bias voltage for current amplifier transistor Q1, which in turn supplies series pass transistor Q2. The power supply incorporates foldback current limiting to prevent damage to components in the event of short ^{30V} circuits. Overvoltage protection is provided by scr Q7 on the A6 card. Zener diode VR1 ~~28V~~ sets the point at which the scr fires. This circuit prevents possible damage to the power amplifier transistors in the event of failure of the regulator circuit. When the threshold is exceeded, the scr fires placing a short circuit across the pa power supply. If there is a failure of regulator transistor Q2, then fuse F2 will blow. If the trouble is of a transient nature only, the scr will fire and cause the power supply to go into the current-limiting mode. In this case, simply turning the power supply off and then on will restore proper operation. ✓

Two external control inputs are provided for remote power control and muting purposes. Transistor Q10 on the A6 card serves as an inverter amplifier. The alarm circuit of the modulator supplies a fixed output voltage under alarm conditions, which is coupled to the base of transistor Q10 causing it to saturate and remove the base driver to the power transistors, thus muting the rf output of the exciter.

External mute input, TB1-16, is provided for external power control or muting purposes. It is coupled to the inverting input of regulator U2 on the A6 card. Full or partial muting of the power output is possible by adjustment of the applied voltage.

4.10 METER AMPLIFIER

The peak voltmeter circuit is contained on audio/regulator card A7 and is used to monitor the following audio levels in the 310Z-2:

Left audio level

Right audio level

Stereo generator baseband output

SCA-1 modulation

SCA-2 modulation

The peak voltmeter circuit is an automatic slideback peak voltmeter type that determines the peak voltage of the complex waveforms monitored by the meter. A basic slideback voltmeter operates by reverse-biasing a diode to a point where the incoming signal can no longer switch on the diode. The reverse dc bias voltage is then equal to the incoming peak voltage (disregarding the intrinsic standoff voltage of the diode). The automatic slideback voltmeter operates in a similar manner by taking the signal voltage that is conducted through the reverse-biased diode, amplifying the signal, rectifying it, and applying the resultant dc as a reverse bias to the diode. The diode will conduct until the dc reverse bias from the amplifiers cuts off diode conduction.

Grounded emitter amplifier Q1 amplifies the wideband complex waveform and feeds it to emitter follower amplifier Q2. The resultant signal is applied to peak detector Q2. At the instant that the first half-cycle of the input complex waveform appears on the base of Q2, the transistor conducts, causing the base signal to appear across load resistor R14. Capacitor C7 couples the signal to peak amplifier Q4. The signal output from Q4 is fed to rectifier Q5, which rectifies the signal and charges capacitor C10 in the negative direction. Capacitor C10 averages the negative output from Q5 into a negative dc potential that appears at the base of feedback bias amplifier Q6. With this negative bias present at the base of PNP transistor Q6 the transistor conducts, increasing the voltage drop across resistor R21. This drives the emitter of Q2 in the negative direction, biasing the transistor to the point where only a small signal peak is conducted by Q2. This reduces the signal voltage across load resistor R14 when the succeeding half-cycles of the wideband input waveform arrive at the base of the peak detector transistor. Due to the gain of transistor stages Q2 and Q4, any conduction of transistor Q2 causes the voltage at the base of Q6 to be sustained at a level that permits Q2 to conduct only during a small portion of the signal peaks. The voltage at the collector of Q2 is then proportional to the peak voltage of the complex wideband waveform. In positions 1 through 5, meter switch S3 connects this voltage through dropping resistor R23 to the front panel meter.

5.1 GENERAL

The 310Z-2 FM Broadcast Exciter, which contains all solid-state circuits, has been carefully inspected and adjusted at the factory by skilled technicians using special test equipment. Therefore, the 310Z-2 should not be readjusted as part of routine maintenance procedures, but instead should be readjusted only after trouble has definitely been traced to misadjustment. When the 310Z-2 is readjusted, adjustments should be performed in accordance with the procedures outlined in paragraph 5.6 using the recommended test equipment listed in table 5-1.

To ensure peak performance and maximum service life, a regular schedule of routine maintenance should be carried out. For the 310Z-2 this routine maintenance should consist only of cleaning and inspecting, and should occasionally include a check of the minimum performance standards for the 310Z-2 in accordance with paragraph 5.7.

CAUTION

The 310Z-2 exciter should not be operated without a load connected to the rf output, and should not be operated over any extended period of time into vswr greater than 2:1.

5.2 CLEANING

Clean the 310Z-2 whenever a perceptible quantity of dust accumulates at any point inside the equipment. A solvent consisting of the following mixture may be used as a cleaning material.

Methylene chloride, 25 percent

Perchloroethylene, 5 percent

Drycleaning solvent, 70 percent by volume

Use the following procedure:

- a. Remove dust from chassis, panels, and components with a soft-bristled brush.
- b. Clean flat surfaces and accessible areas with a lintless cloth moistened with solvent, removing any foreign matter adhering to the equipment. Dry with a clean, dry, lintless cloth.
- c. Wash switch contacts and the less accessible areas with solvent lightly applied with a small soft-bristled brush.

Table 5-1. Required Test Equipment.

ITEM	MANUFACTURERS DESIGNATION
Wideband FM modulation monitor	Collins 900C-3, part no. 758-5812-001
Distortion and noise meter	Hewlett-Packard 334A
Audio vtm	Hewlett-Packard 400L
Vtm	Hewlett-Packard 410B
Wattmeter	Sierra 164B with 181A/250 plug-in element
Stereo test circuit	Fabricated per figure 5-3
Low-distortion af signal generator	Hewlett-Packard 306A
Oscilloscope	Tektronix 581A
Vertical amplifier	Tektronix type 81
Crosstalk test circuit	Fabricated per figure 5-6
FM frequency monitor	Collins 54N-1
SCA monitor	Collins 900F-1

- d. Use a burnishing tool on relay contacts if contacts are corroded or pitted. Apply solvent lightly to relay contacts with a small soft-bristled brush. Dry with a clean, dry, soft-bristled brush.
- e. Use a dry, oil-free jet of air to remove any dust accumulated on the modules, circuit cards, in the card cage, or on components located in the area above the cage.

5.3 LUBRICATION

No lubrication is required.

5.4 INSPECTION

Perform periodic visual inspection of the 310Z-2 at least once each month. Inspect all metal parts for rust, corrosion, and general deterioration. Check circuit cards, wiring, and components for signs of overheating. Check the blower and cabinet fan for normal operation. Check all operating controls for smoothness of operation. Check all connections.

5.5 TEST EQUIPMENT REQUIRED

The test equipment listed in table 5-1, or its equivalent, is required to perform the adjustment and test procedures given in this section.

5.6 ALIGNMENT AND ADJUSTMENT

The maintenance controls for the 310Z-2 that are referenced in the following procedures are shown on figure 5-1 and their function is described in table 5-2.

CAUTION

Do not attempt to make any adjustment to the 310Z-2 unless trouble has been definitely traced to misadjustment and the recommended test equipment is available.

5.6.1 Power Supply Checks and Adjustments

- a. Remove exciter from transmitter or equipment rack, remove rear cover, and connect equipment as shown in figures 5-2 and 5-3.
- b. Measure voltage across C3. It should be between 22.5 and 25.5 V dc.
- c. Measure voltage across C5. It should be between 22.5 and 25.5 V dc.
- d. Connect vtvm across XA5-26 and place POWER switch to ON.
- e. Vtvm indication should be between +10 and +26 V dc.
- f. Mark position of POWER ADJUST control (R1), and then turn it fully clockwise. Vtvm should indicate +24 to +27 V dc.
- g. Turn POWER ADJUST control fully counterclockwise and ensure that vtvm indicates +6 to +10 V dc.
- h. Return POWER ADJUST control to its original position, place POWER switch to OFF, and remove vtvm.
- i. Replace rear cover.

5.6.2 Modulator Tests

5.6.2.1 AFC Adjustment

Check to see that meter M1 on the modulator module A4 reads in the green area. If not, adjust the AFC ADJUST potentiometer A4R7 so that meter is in the green area. If it cannot be adjusted to the green area, remove the modulator from the card cage and place it on the extender module. Remove the cover and carefully adjust A4R7 to the center of its range (five turns from end stop) then carefully adjust oscillator card A4L5 to center the meter in the green portion of the range. Check adjustment of the AFC ADJUST potentiometer to see that it has control of the meter and that the alarm light is extinguished. Reinstall the cover and replace the module in the card cage.

5.6.2.2 Frequency Adjustment

Adjust FREQ ADJUST capacitor C38 for assigned frequency.

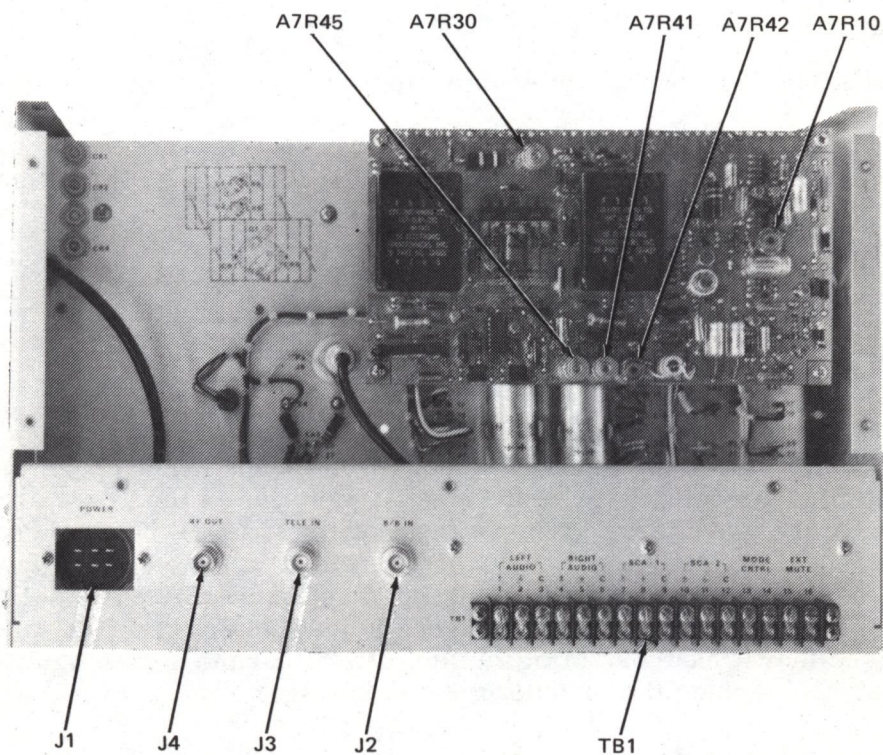
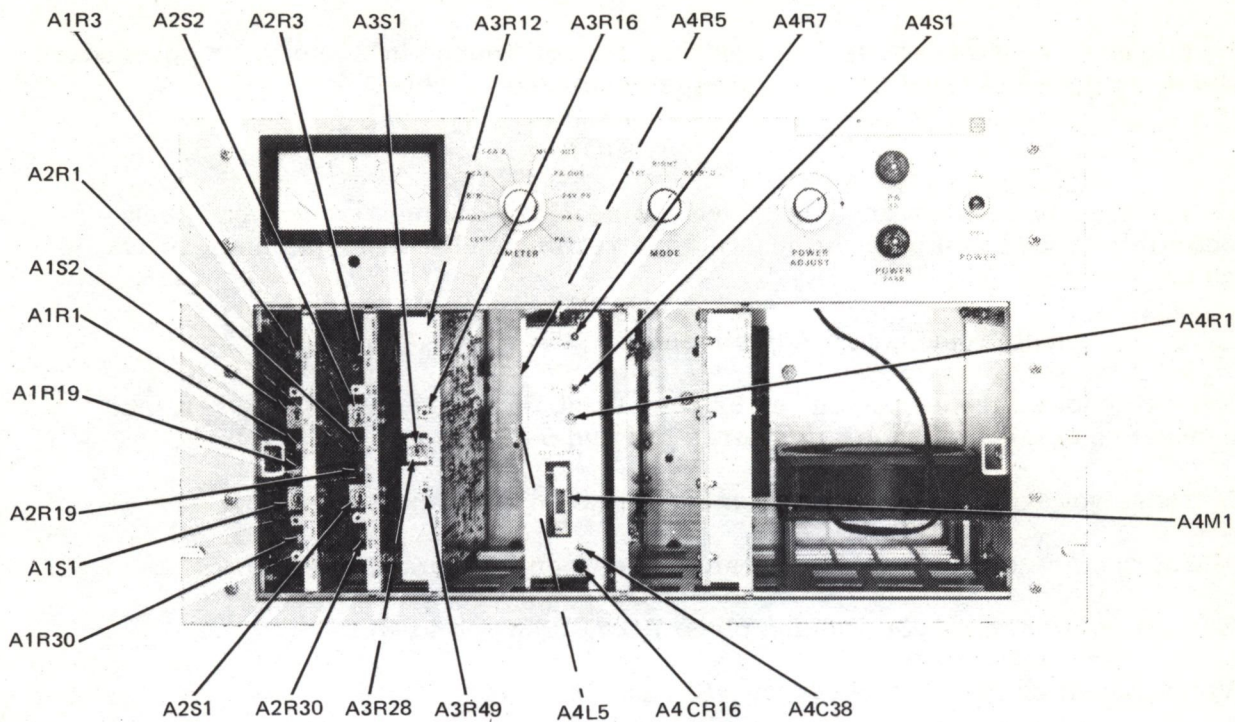

B528 097 Rp

Figure 5-1. 310Z-2 FM Exciter, Maintenance Controls.

Table 5-2. Maintenance Controls.

CONTROL	FUNCTION
786W-1 SCA Generator Card A1/A2	
R3 - modulation level	Sets the sca audio input levels to the sca modulator.
R1 - mute level	Sets the minimum audio level that will activate the sca subcarrier mute circuit.
R30 - output level	Sets the sca subcarrier output level.
R19 - frequency	Sets the sca subcarrier frequency.
S1 - mute enable	ON position enables mute circuit to remote the 67-kHz sca oscillator output when there is no sca audio input. OFF position disables mute circuit for maintenance.
S2 - 7.5-KHZ DEV/3.5-KHZ DEV sca deviation switch	7.5-KHZ position causes the front panel meter to indicate 0 vu when S3 is in the corresponding SCA-() position and sca subcarrier deviation is 7.5 kHz. 3.5-KHZ position causes the front panel meter to indicate 0 vu when S3 is in the corresponding SCA-() position and sca subcarrier deviation is 3.5 kHz.
786V-1 Stereo Generator Card A3	
R12 - sideband suppression	Sets the switching point of Q3.
R28 - sideband suppression	Sets the switching point of Q6.
R16 - channel separation	Sets the level of the L + R signal from Q1 and Q4 applied to the multiple output to give proper levels for good stereo channel separation.
R49 - pilot carrier level	Sets the level of the 19-kHz pilot carrier applied to the multiplex output.
S1 - pilot on/off switch	Switches the 19-kHz pilot carrier to the multiplex output.
Modulator Card A4	
R1 - B/B LEVEL	Adjusts baseband modulation sensitivity.
R7 - AFC ADJUST	Adjusts free-running frequency of modulator.

Table 5-2. Maintenance Controls (Cont).

CONTROL	FUNCTION
C38 - FREQ adjust	Sets exciter center frequency.
S1 - AFC ON/OFF	Disables AFC system for test purposes.
R5 - mod bias	Sets bias voltage on modulator diodes for best linearity.
L5 - oscillator frequency	Sets coarse frequency modulator.
CR16 - ALARM	Provides out-of-lock indication for AFC circuit.
M1 - AFC LEVEL meter	Displays AFC voltage.
Audio/Meter Regulator Card A7	
R30 - monaural gain vernier	Matches monaural mode to stereo operation
R10 - meter amplifier adjust	Adjusts meter deflections by 10 percent
R41 - overall gain vernier	Allows matching of both stereo channels
R45 - mid-frequency gain vernier	Same.
R42 - high-frequency gain vernier	Same.

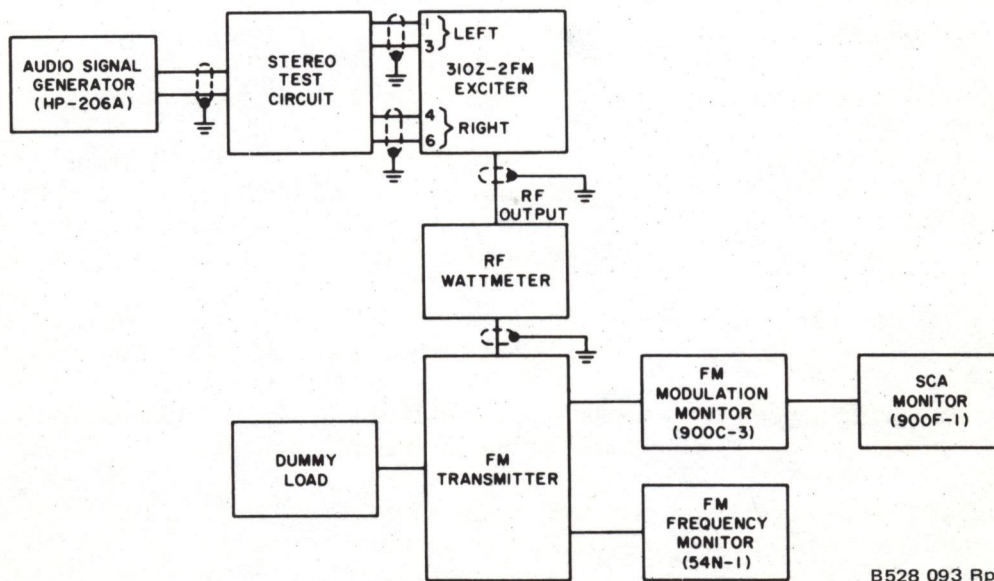

Figure 5-2. Test Equipment Connections to 310Z-2 for Adjustment and Test Procedures.

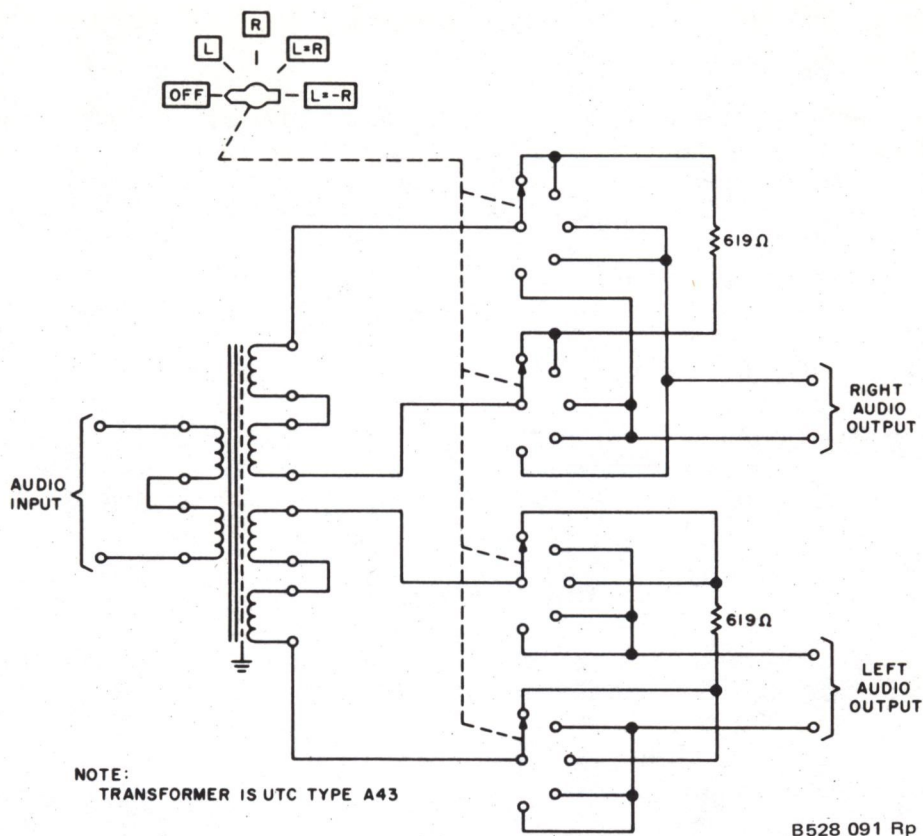

Figure 5-3. Stereo Test Circuit, Schematic Diagram.

5.6.3 Audio Adjustments - Preemphasis Tracking and Linear Crosstalk

Read and understand procedures for measurement of main and subchannel audio in modulation monitor instruction manual. Connect 310Z-2 exciter as shown in figure 5-2, and set S2 to stereo mode.

- a. Set A7R41, A7R42, and A7R45 to midrange.
- b. Set stereo selector to L = R and set audio oscillator for 100 percent total modulation with pilot switch off at 150 Hz.
- c. Set monitor to read L = -R or subchannel audio. Adjust A7R41 for minimum reading.
- d. Set audio oscillator to 1500 Hz and adjust oscillator for 100 percent total modulation. Read subchannel audio and adjust A7R45 for minimum reading.
- e. Readjust audio oscillator to 15 kHz and modulation to 100 percent total. Set monitor to read subchannel audio. Adjust A7R42 for minimum reading.
- f. Repeat steps b. through e. and optimize all three adjustments for best overall crosstalk.

- g. Repeat steps b. through e. without readjustment of A7R41, A7R42, and A7R45 feeding L = -R and reading main channel audio.
- h. Make minor readjustments to A7R41, A7R42, and A7R45 if necessary for best overall crosstalk measurements from subchannel to main channel and main channel to subchannel. They should exceed 45 dB for all frequencies from 50 Hz to 15 kHz.
- i. Set up exciter in STEREO mode and feed +10 dB mW at 400 Hz into the left channel. Turn on the 19-kHz pilot and adjust it to 9 percent. Read total modulation on the modulation monitor. Adjust B/B LEVEL control A4R1 on the modulator for 100 percent.
- j. Set exciter to left mono mode and adjust A7R30 for 100-percent modulation.

5.6.4 SCA Generator Output Level Adjustment

- a. With equipment connected as shown in figure 5-2, set MODULATOR METER switch on FM modulation monitor to SCA MOD.
- b. Place MUTE ENABLE switch (on sca generator card) to OFF.
- c. Adjust OUTPUT LEVEL control R30 for 10-percent modulation as indicated on the 0- to 30-percent scale on FM modulator monitor.
- d. Turn MUTE ENABLE switch to ON and note that indication on the FM modulation monitor decreases to zero.

5.6.5 SCA Generator Frequency Adjustment

- a. With equipment connected as shown in figure 5-2, turn stereo test circuit switch to OFF.
- b. Check the sca output frequency as indicated on the sca frequency monitor (Collins 900F-1 or equivalent).
- c. Adjust A1R19 until sca frequency monitor indicates 67 kHz.

5.6.6 Stereo Generator Adjustment

- a. Connect equipment as shown in figure 5-2.
- b. Set MODE switch on 310Z-2 front panel to STEREO.
- c. Set MODULATION METER switch on FM modulator monitor to TOTAL MOD.
- d. Place 19-kHz pilot carrier switch on stereo generator card to ON.
- e. Turn stereo test circuit (figure 5-3) switch to L position (left modulation only).
- f. Set audio oscillator (HP206A or equivalent) to 5000 Hz and adjust the output amplitude for 100-percent total modulation on FM modulation monitor.
- g. Read separation on monitor and adjust R16 on the stereo generator for best separation.

5.7 MINIMUM PERFORMANCE STANDARDS

The 310Z-2 should be tested in accordance with the following procedures after alignment and adjustment. In addition, the following tests should be used to determine if the 310Z-2 is operating properly. Table 5-3 lists those tests that are applicable to monaural, stereo, and SCA functions of the 310Z-2. If it is desired to test the 310Z-2 for monaural only, perform only those tests listed in table 5-3 for monaural, etc.

5.7.1 Output Frequency

- a. Connect the equipment as shown in figure 5-2, and turn stereo test circuit switch to OFF.
- b. Place POWER switch to ON and measure output frequency. Allow 10 minutes warmup.
- c. If the output frequency is incorrect (should be the customer-selected frequency of 88 to 108 MHz), readjust the frequency control on the FM modulator.

5.7.2 Output Power

- a. Connect equipment as shown in figure 5-2.
- b. Adjust OUTPUT POWER control until rf wattmeter indicates desired power output.

5.7.3 FM Noise

- a. Connect the equipment as shown in figure 5-2.
- b. Turn MODE switch on 310Z-2 to LEFT.
- c. Turn MODULATION METER switch on the FM modulation monitor to TOTAL MOD.
- d. Turn stereo test circuit switch to L.
- e. Set output of audio oscillator to 400 Hz and 100-percent modulation as indicated on the FM modulation monitor.
- f. Turn DECIBELS switch on FM modulation monitor to 0 and METER switch to MAIN CHAN AUDIO.
- g. Turn METER ADJUST control until 0 dB is indicated on FM modulation monitor front panel meter.
- h. Remove 400-Hz monaural input signal and turn the DECIBELS switch clockwise until a reading is observed on the meter.
- i. The main channel FM noise is the algebraic sum of the DECIBELS switch and the meter indication, and should be no more than -65 dB.
- j. Turn METER switch to SUB CHAN AUDIO.
- k. The subchannel FM noise is the algebraic sum of the DECIBELS switch setting and the meter indication, and it should be no more than -65 dB.

Table 5-3. Tests.

MONAURAL (PARA NO.)	STEREO (PARA NO.)	SCA (PARA NO.)	TEST
5.7.1	5.7.1	5.7.1	Output frequency
5.7.2	5.7.2	5.7.2	Output power
5.7.3	5.7.3	5.7.3	FM noise
5.7.4			Frequency response (monaural)
5.7.5			Harmonic distortion (monaural)
	5.7.6		Frequency response (stereo)
	5.7.7		Harmonic distortion (stereo)
	5.7.8		Subcarrier suppression
	5.7.9		Channel separation
	5.7.10		Main-to-subchannel crosstalk
	5.7.11		Subchannel-to-main crosstalk
		5.7.12	Sca input test
		5.7.13	Sca noise test
		5.7.14	Sca mute test
		5.7.15	Sca frequency response

5.7.4 Frequency Response (Monaural)

- a. With the equipment connected as shown in figure 5-2, set the MOD switch on the 310Z-2 to LEFT and the stereo test circuit switch to L.
- b. Set the audio generator (HP206A or equivalent) for a frequency of 50 Hz.
- c. Adjust the output of the audio generator for 100-percent modulation as indicated on the FM modulation monitor.

- d. Vary the audio generator and maintain 100-percent modulation for frequencies of 100, 400, 1000, 5000, 7500, 10,000 and 15,000 Hz.
- e. Ensure that attenuator settings for each frequency are within the limits of the 75-microsecond preemphasis curve as defined by the FCC.

5.7.5 Harmonic Distortion (Monaural)

- a. Connect the equipment as shown in figure 5-2.
- b. Turn MODE switch on the 310Z-2 to the LEFT position.
- c. Turn MODULATION METER switch on the FM modulation monitor (900C-3) to TOTAL MOD and the DE-EMPHASIS switch to IN.
- d. Turn stereo test circuit switch to L.
- e. Set the audio oscillator (HP206A) to 50 Hz, and adjust the output amplitude for 100-percent total modulation on the FM modulation monitor.
- f. Turn MODULATION METER switch on FM modulation monitor to MAIN CHAN AUDIO.
- g. Connect distortion meter (HP334A or equivalent) to the DISTORTION METER jack on the FM modulation monitor.
- h. Ensure that the distortion meter indication is not more than 0.25 percent.
- i. Repeat steps e. through h. for modulating frequencies of 100, 400, 1000, 5000, 7500, 10,000 and 15,000 Hz.

5.7.6 Frequency Response (Stereo)

- a. With equipment connected as shown in figure 5-2, set the MODULATION switch on the 310Z-2 to STEREO and the stereo test circuit switch to LEFT.
- b. Turn on 19-kHz pilot.
- c. Repeat steps b. through e. of paragraph 5.7.4.
- d. Place STEREO TEST CIRCUIT switch to RIGHT.
- e. Repeat steps b. through e. of paragraph 5.7.4.

5.7.7 Harmonic Distortion (Stereo)

- a. With equipment connected as shown in figure 5-2, place PILOT CARRIER switch to ON.
- b. Turn MODE switch on 310Z-2 to STEREO.
- c. Turn MODULATION METER switch on 900C-3 to TOTAL MOD, and place DE-EMPHASIS switch to OUT.

- d. Set switch on stereo test circuit (figure 5-3) to L = R.
- e. Set audio oscillator (HP206A) to 50 Hz, and adjust output amplitude for 100-percent total modulation on 900C-3.
- f. Connect distortion meter (HP334A or equivalent) to LEFT AUDIO jack on the 900C-3.
- g. Measure and record total distortion for modulating frequencies of 50, 100, 400, 1000, 5000 and 7500 Hz. Maintain modulation on 900C-3 at 100 percent for all frequencies, and distortion should be not more than 0.5 percent.
- h. Connect distortion meter to RIGHT AUDIO jack on 900C-3 and repeat step g.

5.7.8 Subcarrier Suppression

- a. With equipment connected as shown in figure 5-2, place PILOT CARRIER switch to OFF.
- b. Ensure that there is no input to the SCA generator of the 310Z-2 exciter.
- c. Turn DECIBELS switch on FM modulation monitor to 0.
- d. Turn METER switch on FM modulation monitor to TOTAL MOD.
- e. Adjust the audio generator for a frequency of 15,000 Hz, and adjust the amplitude for 90-percent modulation indication on the FM modulation monitor.
- f. Turn METER switch on FM modulation monitor to MAIN CHAN AUDIO, and adjust METER ADJUST control until meter indicates 0 dB.
- g. Turn METER switch on FM modulation monitor to SUBCAR, and rotate the DECIBELS switch in a clockwise direction until a meter indication is observed.
- h. The setting of the DECIBELS switch indicates the subcarrier suppression; it should be at least -45 dB.

5.7.9 Channel Separation

It is recommended that the channel separation test be performed using the Collins 900C-3 FM Modulation Monitor.

- a. Connect equipment as shown in figure 5-2.
- b. Turn MODULATION switch on front panel of 310Z-2 to STEREO.
- c. Turn MODULATION METER switch on FM modulation monitor (900C-3) to TOTAL MOD.
- d. Place 19-kHz PILOT CARRIER switch A2A1 to ON.
- e. Turn stereo test circuit switch to L.

- f. Set audio generator (HP206A) to 5000 Hz, and adjust output amplitude for 100-percent total modulation on FM modulation monitor.
- g. Set METER switch on front panel of FM modulation monitor to LEFT AUDIO.
- h. Set DECIBELS switch on front panel of FM modulation monitor to 0, and turn METER ADJUST control until an indication of 0 dB is obtained on the front panel meter.
- i. Switch from left channel modulation to right channel modulation, and turn DECIBELS switch in a clockwise direction until an indication is observed on the front panel meter.
- j. Adjust A3R16 for best channel separation indicated on meter. The channel separation is the algebraic sum of the DECIBELS switch setting and the meter indication.
- k. Repeat steps f. through j. for frequencies of 50, 100, 400, 1000, 5000, 7500, 10,000 and 15,000 Hz, except do not readjust A3R16.
- l. To obtain channel separation measurements with audio applied to the right channel and measurements taken in the left channel, repeat steps e. through i. and substitute left for right and right for left where these instructions are indicated, but do not readjust A3R16.

5.7.10 Main Channel to Subchannel Nonlinear Crosstalk

- a. Connect the equipment as shown in figure 5-4. The crosstalk test circuit shown on figure 5-5 must be fabricated for this test.
- b. Set the crosstalk test circuit switch to MAIN and the FREQ RANGE SELECT switch to 50/400.
- c. Turn the MODULATION switch on the 310Z-2 to STEREO.
- d. Adjust the audio generator (HP206A or equivalent) to a frequency of 50 Hz, and adjust the output level for 90-percent main channel modulation as indicated on the FM modulation monitor.
- e. On the FM modulation monitor, place the METER switch to MAIN CHAN AUDIO, turn the DECIBELS switch to 0, and turn the METER ADJUST control until 0 dB is indicated on the meter.
- f. Turn METER switch to SUB CHAN AUDIO, and turn DECIBELS switch clockwise until an indication on the front panel meter of the FM modulation monitor is observed.
- g. Turn adjustments on crosstalk test circuit until a null is observed on the FM modulation monitor meter.

NOTE

These adjustments are critical and require special attention to achieve the proper null.

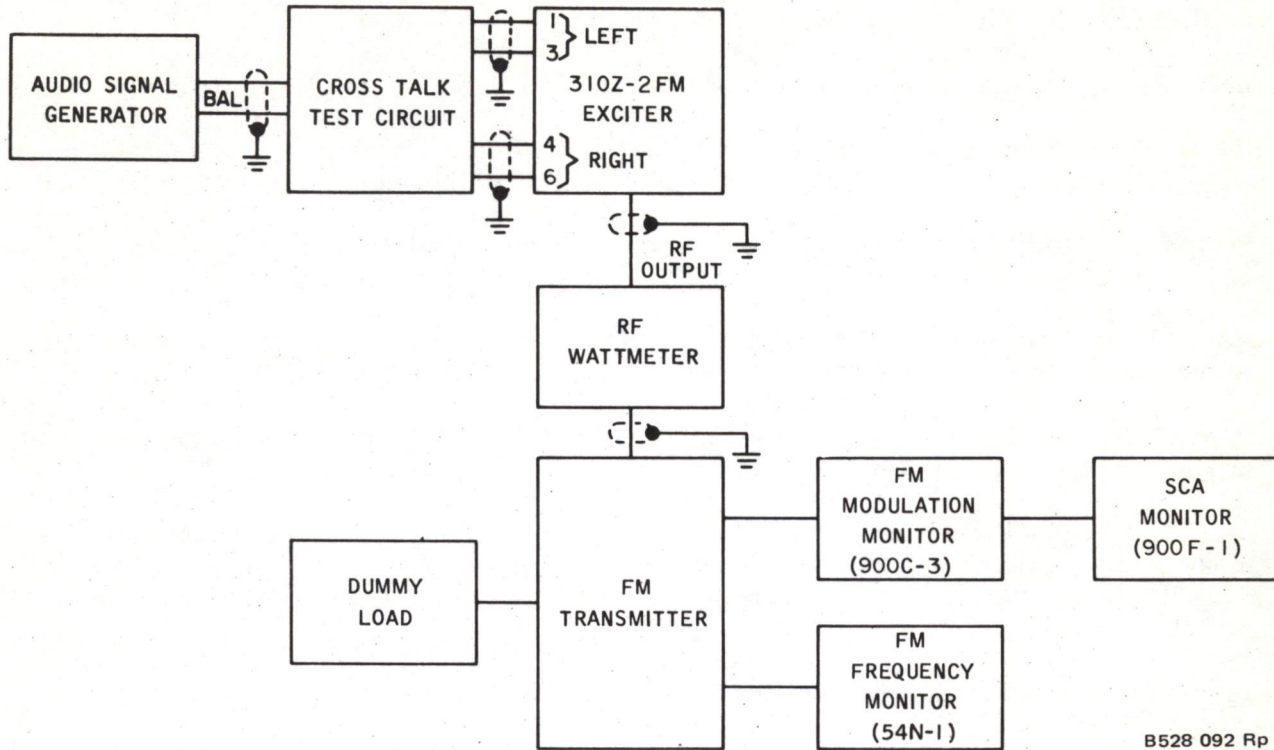

B528 092 Rp

Figure 5-4. Test Equipment Connections to 310Z-2 for Crosstalk Test.

- h. Crosstalk is the algebraic sum of the DECIBELS switch setting and the meter indication. The main channel into subchannel crosstalk should be not more than -50 dB from 50 to 15,000 Hz.
- i. Repeat the above procedure for frequencies of 100, 400, 1000, 5000, 7500, 10,000 and 15,000 Hz. Ensure that the proper frequency range is selected by the FREQ RANGE SELECT switch of the crosstalk test circuit.

5.7.11 Subchannel to Main Channel Nonlinear Crosstalk

- a. With the test equipment connected as shown in figure 5-4, set the crosstalk test circuit switch to SUB and the FREQ RANGE SELECT switch to 50/400.
- b. Adjust the audio generator (HP206A or equivalent) to a frequency of 50 Hz, and adjust the output level for 90-percent subchannel modulation as indicated on the FM modulation monitor.
- c. Turn METER switch to MAIN CHAN AUDIO, and turn DECIBELS switch clockwise until an indication is observed.

5.7.12 SCA Input Test

- a. With the equipment connected as shown in figure 5-2, place the MODULATION METER switch on the FM modulation monitor to SCA MOD.

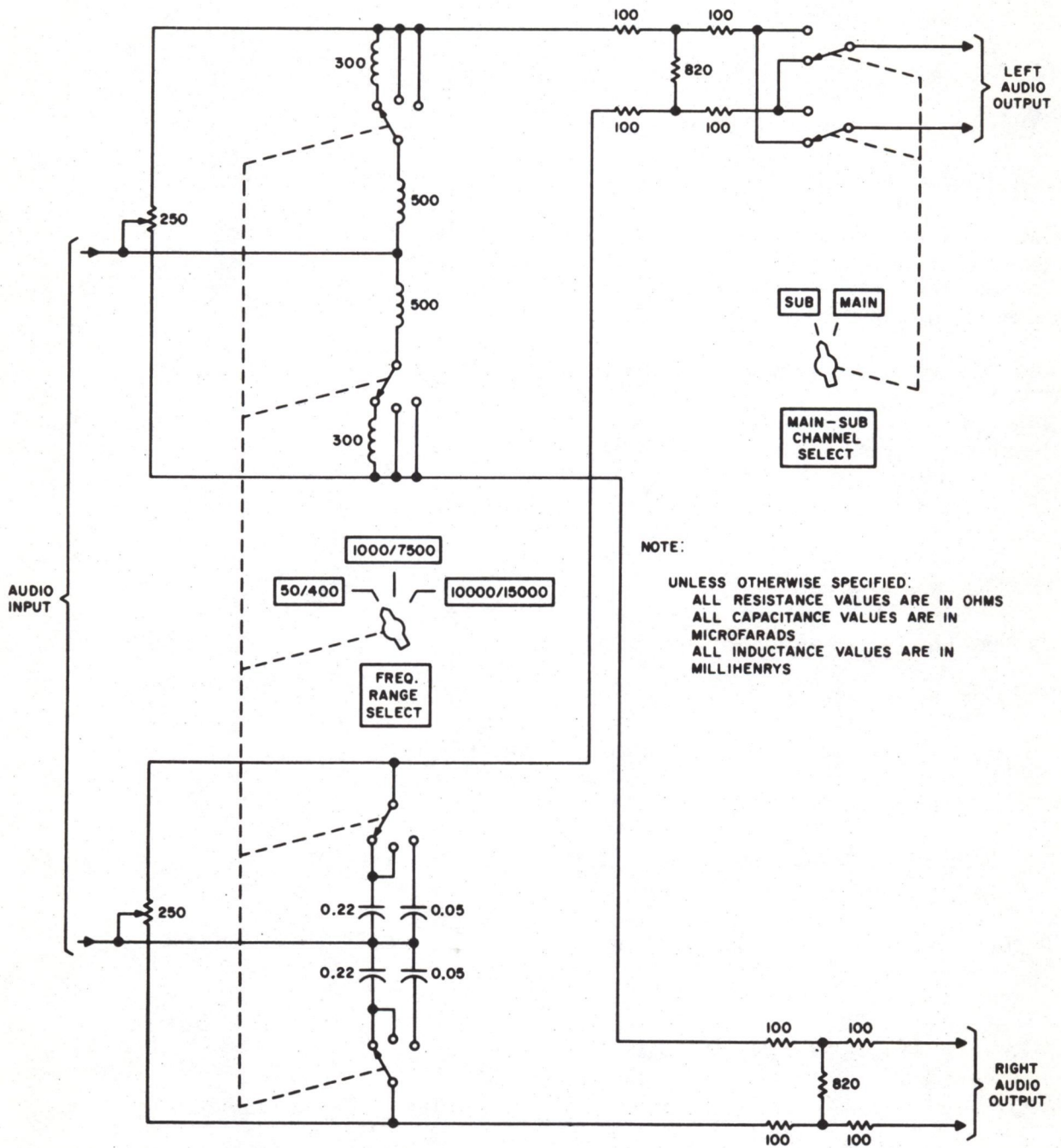

B528 094 Rp

Figure 5-5. Nonlinear Crosstalk Test Circuit, Schematic Diagram.

- b. Place MUTE ENABLE switch (on sca generator card) to OFF.
- c. Place POWER switch to ON, and adjust SCA OUTPUT LEVEL control A1R30 for an indication of 10-percent modulation on the 0- to 30-percent scale on the meter of the FM modulation monitor.

5.7.13 SCA Noise Test

- a. With equipment connected as in figure 5-2, place MUTE DISABLE switch to OFF.
- b. Connect audio generator (HP206A) to sca input terminals of exciter.
- c. Set the audio generator for a frequency of 400 Hz and an output level of +10 dB mW.
- d. Connect ac voltmeter (HP403B) across the audio output (TB1-1 and TB1-2) of the sca modulation monitor (900F-1).
- e. Record the 400-Hz reference signal level as indicated on the ac voltmeter.
- f. Remove the sca input signal from the 310Z-2 exciter, and increase the sensitivity of the ac voltmeter until a reading is indicated.
- g. The difference between the levels recorded in steps e. and f. should be not less than 55 dB.

5.7.14 SCA Mute Circuit Test

- a. Connect equipment as shown in figure 5-2.
- b. Connect audio signal generator (HP206A) to terminals TB1-10 and TB1-12.
- c. Place PILOT CARRIER switch on stereo generator card to OFF.
- d. Turn stereo test circuit switch to OFF.
- e. Adjust audio signal generator connected to terminals TB1-10 and TB1-12 for 400 Hz at 6 dB mW.
- f. Turn MUTE LEVEL control A1R1 fully counterclockwise.
- g. Observe the sca subcarrier level on the sca monitor.
- h. Place MUTE ENABLE switch to ON.
- i. After a few seconds, note that the sca subcarrier level is still indicated on sca monitor.
- j. Remove input to sca generator card, and observe that sca subcarrier indicated on sca monitor is (decreased to zero) within 3 to 4 seconds.
- k. Adjust audio signal generator for 400 Hz at 6-dB mW input to exciter.

- l. Adjust attenuator on signal generator to reduce input level 30 dB.
- m. Observe the sca subcarrier on sca monitor, and ensure that is still present after 3 to 4 seconds indicating that mute circuit did not cut off carrier.
- n. Remove audio signal generator.

5.7.15 SCA Frequency Response

- a. With equipment connected as in figure 5-2, place the pilot carrier switch on stereo generator card to OFF.
- b. Connect audio generator (HP206A) to sca input terminals TB1-7 and TB1-9 (21 kHz) or TB1-10 and TB1-12 (67 kHz) of exciter.
- c. Turn stereo test circuit switch to OFF.
- d. Turn METER switch on sca modulation monitor (900F-1) to sca modulation monaural mode.
- e. Set audio generator frequency to 50 Hz, and adjust output amplitude for 3.5-kHz deviation on the sca modulation monitor.
- f. While maintaining 3.5-kHz deviation, vary the audio generator frequency to 100, 400, 1000, and 5000 Hz. The audio generator attenuator settings for each frequency should follow the 75-microsecond preemphasis curve as specified by the FCC.

5.8 FREQUENCY CHANGE

If it is desired to change the output frequency of the 310Z-2, crystal A4Y1 located in the oven on the modulator card must be changed. Table 5-4 lists the channel frequency versus crystal frequency and the Collins part number for each crystal.

Table 5-4. Crystal Part Number.

CHANNEL FREQ (MHz)	CRYSTAL FREQ (kHz)	COLLINS PART NUMBER	CHANNEL FREQ (MHz)	CRYSTAL FREQ (kHz)	COLLINS PART NUMBER
88.1	1376.5625	289-7246-010	96.1	1501.5625	289-7246-410
88.3	1379.6875	289-7246-020	96.3	1504.6875	289-7246-420
88.5	1382.8125	289-7246-030	96.5	1507.8125	289-7246-430
88.7	1385.9375	289-7246-040	96.7	1510.9375	289-7246-440
88.9	1389.0625	289-7246-050	96.9	1514.0625	289-7246-450
89.1	1392.1875	289-7246-060	97.1	1517.1875	289-7246-460
89.3	1395.3125	289-7246-070	97.3	1520.3125	289-7246-470
89.5	1398.4375	289-7246-080	97.5	1523.4375	289-7246-480
89.7	1401.5625	289-7246-090	97.7	1526.5625	289-7246-490
89.9	1404.6875	289-7246-100	97.9	1529.6875	289-7246-500
90.1	1407.8125	289-7246-110	98.1	1532.8125	289-7246-510
90.3	1410.9375	289-7246-120	98.3	1535.9375	289-7246-520
90.5	1414.0625	289-7246-130	98.5	1539.0625	289-7246-530
90.7	1417.1875	289-7246-140	98.7	1542.1875	289-7246-540
90.9	1420.3125	289-7246-150	98.9	1545.3125	289-7246-550
91.1	1423.4375	289-7246-160	99.1	1548.4375	289-7246-560
91.3	1426.5625	289-7246-170	99.3	1551.5625	289-7246-570
91.5	1429.6825	289-7246-180	99.5	1554.6875	289-7246-580
91.7	1432.8125	289-7246-190	99.7	1557.8125	289-7246-590
91.9	1435.9375	289-7246-200	99.9	1560.9375	289-7246-600
92.1	1439.0625	289-7246-210	100.1	1564.0625	289-7246-610
92.3	1442.1825	289-7246-220	100.3	1567.1875	289-7246-620
92.5	1445.3125	289-7246-230	100.5	1570.3125	289-7246-630
92.7	1448.4375	289-7246-240	100.7	1573.4375	289-7246-640
92.9	1451.5625	289-7246-250	100.9	1576.5625	289-7246-650
93.1	1454.6875	289-7246-260	101.1	1579.6875	289-7246-660
93.3	1457.8125	289-7246-270	101.3	1582.8125	289-7246-670
93.5	1460.9375	289-7246-280	101.5	1585.9375	289-7246-680
93.7	1464.0625	289-7246-290	101.7	1589.0625	289-7246-690
93.9	1467.1875	289-7246-300	101.9	1592.1875	289-7246-700
94.1	1470.3125	289-7246-310	102.1	1595.3125	289-7246-710
94.3	1473.4375	289-7246-320	102.3	1598.4375	289-7246-720
94.5	1476.5625	289-7246-330	102.5	1601.5625	289-7246-730
94.7	1479.6875	289-7246-340	102.7	1604.6875	289-7246-740
94.9	1482.8125	289-7246-350	102.9	1607.8125	289-7246-750
95.1	1485.9375	289-7246-360	103.1	1610.9375	289-7246-760
95.3	1489.0625	289-7246-370	103.3	1614.0625	289-7246-770
95.5	1492.1875	289-7246-380	103.5	1617.1875	289-7246-780
95.7	1495.3125	289-7246-390	103.7	1620.3125	289-7246-790
95.9	1498.4375	289-7246-400	103.9	1623.4375	289-7246-800

Table 5-4. Crystal Part Number (Cont).

CHANNEL FREQ (MHz)	CRYSTAL FREQ (kHz)	COLLINS PART NUMBER	CHANNEL FREQ (MHz)	CRYSTAL FREQ (kHz)	COLLINS PART NUMBER
104.1	1626.5625	289-7246-810	106.1	1657.8125	289-7246-910
104.3	1629.6875	289-7246-820	106.3	1660.9375	289-7246-920
104.5	1632.8125	289-7246-830	106.5	1664.0625	289-7246-930
104.7	1635.9375	289-7246-840	106.7	1667.1875	289-7246-940
104.9	1639.0625	289-7246-850	106.9	1670.3125	289-7246-950
105.1	1642.1875	289-7246-860	107.1	1673.4375	289-7246-960
105.3	1645.3125	289-7246-870	107.3	1676.5625	289-7246-970
105.5	1648.4375	289-7246-880	107.5	1679.6875	289-7246-980
105.5	1651.5625	289-7246-890	107.7	1682.8125	289-7246-990
105.9	1654.6875	289-7246-900	107.9	1685.9375	289-7247-010

6.1 GENERAL

This section provides parts lists and parts locations for all electrical components of the 310Z-2 FM Exciter. Figures 6-1 through 6-3 provide general views of the 310Z-2 FM Exciter with various access panels removed. The remaining figures with their corresponding parts lists identify all electrical components. These figures and parts lists are in order according to assembly reference designation.

6.2 ORDERING REPLACEMENT PARTS

Refer to the information inside the front cover for instructions on how to order replacement parts.

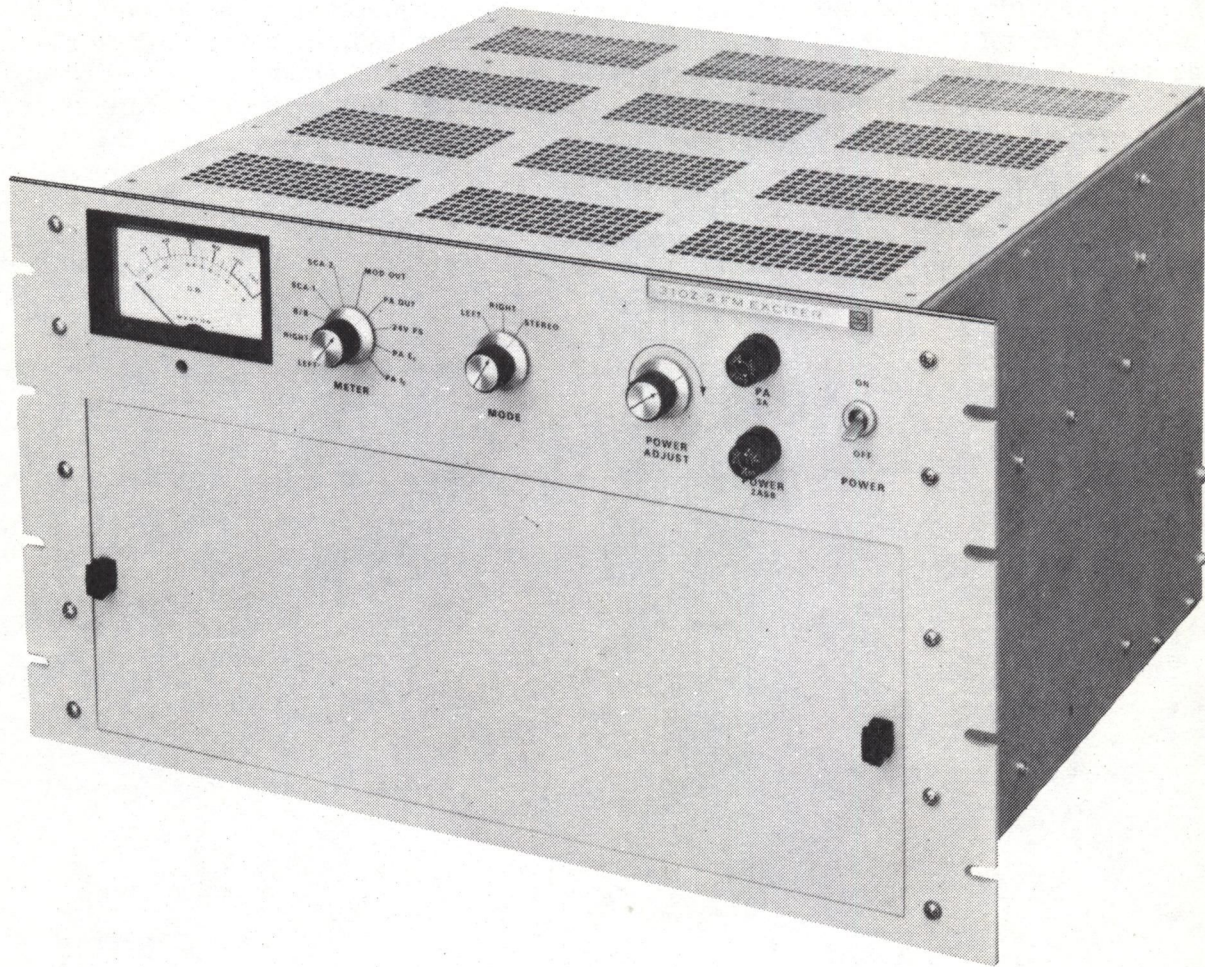

B700 3285 Rp

Figure 6-1. 310Z-2 FM Exciter (Sheet 1 of 3).

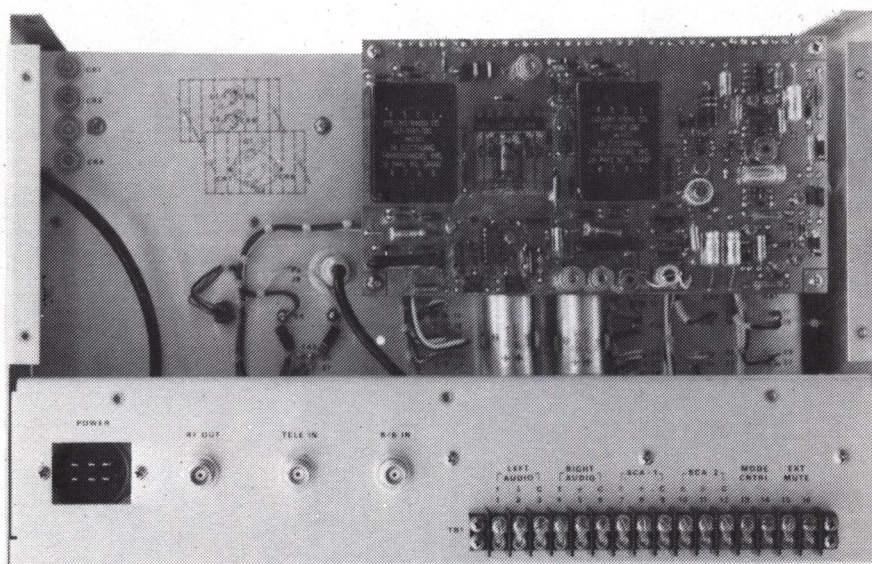
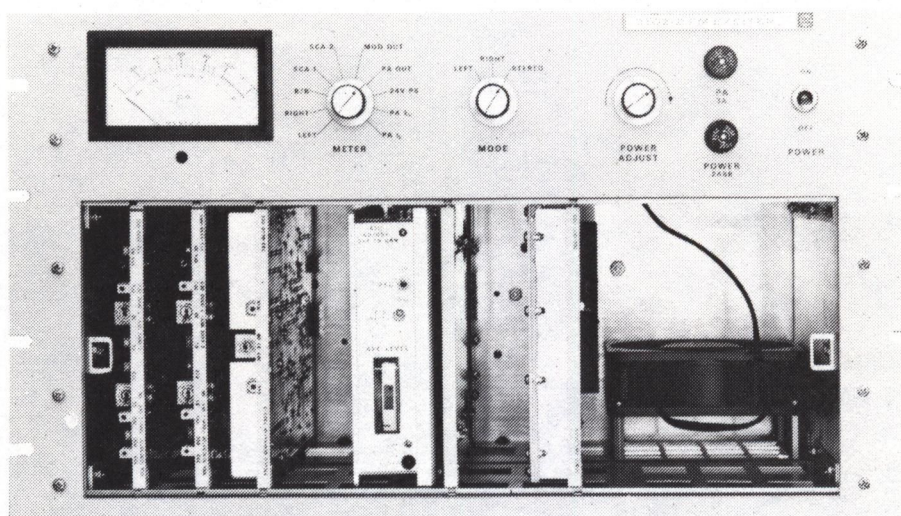

B700 3283 Rp

Figure 6-2. 310Z-2 FM Exciter (Sheet 2 of 3).

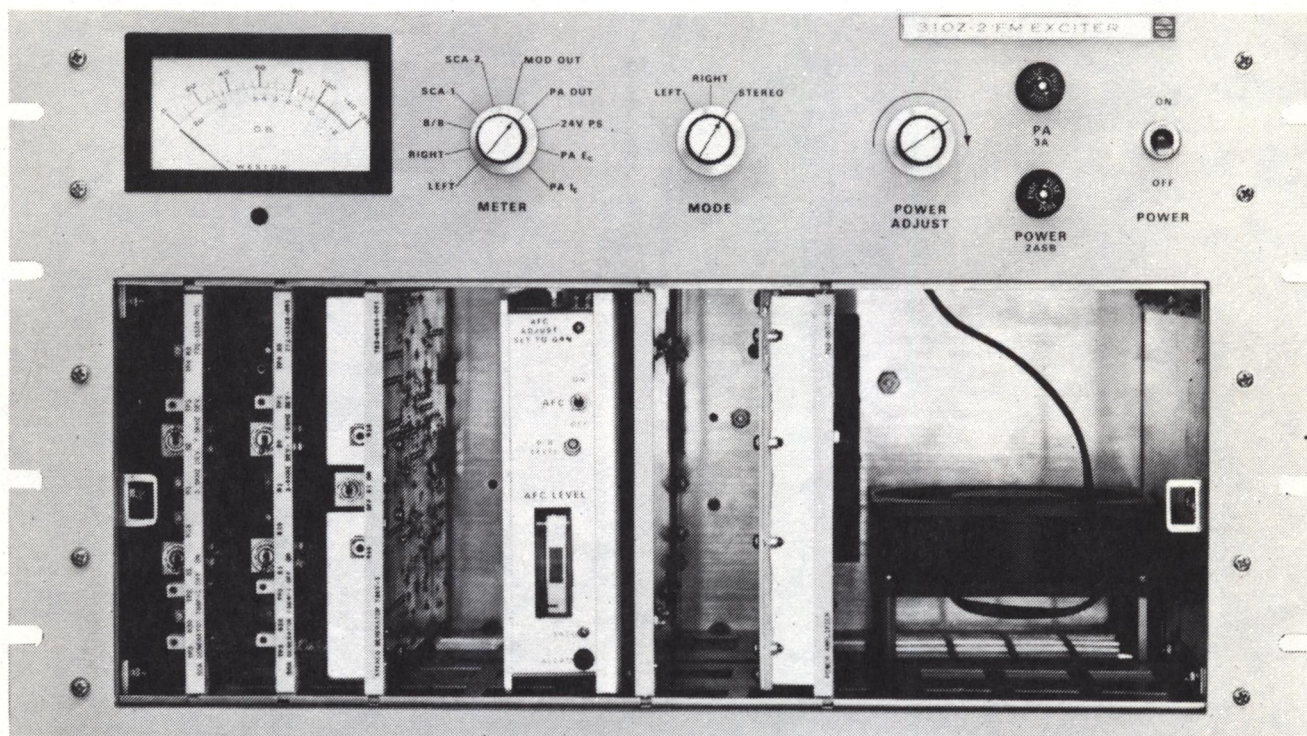

B700 3284 Rp

Figure 6-3. 310Z-2 FM Exciter (Sheet 3 of 3).

SYMBOL	DESCRIPTION	COLLINS PART NUMBER
310Z-2 FM EXCITER		622-2184-001
A1	EXTENDER BOARD	781-5365-001
A2	SCA GENERATOR 786W-1	772-5338-001
A3	SCA GENERATOR 786W-1	772 5338-001
A3	STL INTERFACE 785E-1	622-2374-001
A4	STEREO GENERATOR 786V-1	783-6648-001
A4	MODULATOR/EXCITER	627-6695-001
A5	POWER AMPLIFIER	769-0830-001
A6	AUDIO/MTR REGULATOR	627-9773-001
B1	BLOWER	009-1829-030
C1	CAPACITOR	3900UF 50 V 183-1278-370
C2	CAPACITOR	3900UF 50 V 183 1278-370
C3	CAPACITOR	1000PF 500 V 913-1292-000
C4	CAPACITOR	1000UF 50 V 183-1282-140
C5	CAPACITOR	1000UF 50 V 183 1282-140
C6	CAPACITOR	1000UF 50 V 183-1282-140
C7	CAPACITOR	1000PF 500 V 913-1292-000
C8	CAPACITOR	1000PF 500 V 913 1292-000
C9	CAPACITOR	1000PF 500 V 913-1292-000
C10	CAPACITOR	1000PF 500 V 913 1292-000
C11	CAPACITOR	1000PF 500 V 913-1292-000
C12	CAPACITOR	1000PF 500 V 913 1292-000
C13	CAPACITOR	1000PF 500 V 913-1292-000
C14	CAPACITOR	1000PF 500 V 913 1292-000
C15	CAPACITOR	1000PF 500 V 913-1292-000
C16	CAPACITOR	1000PF 500 V 913 1292-000
C17	CAPACITOR	1000PF 500 V 913-1292-000
C18	CAPACITOR	0.1UF 200 V 913-3681-000
C19	CAPACITOR	0.1UF 200 V 913 3681-000
C20	CAPACITOR	0.1UF 200 V 913-3681-000
C21	CAPACITOR	100PF 500 V 912-2816-000
CR1	DIODE	1N1202 353-1889-000
CR2	DIODE	1N1202 353 1889-000
CR3	DIODE	1N1202 353-1889-000
CR4	DIODE	1N1202 353 1889-000
CR5	DIODE	1N4003 353-6442-030
CR6	DIODE	1N4003 353 6442-030
CR7	DIODE	1N4003 353-6442-030
CR8	DIODE	1N4003 353 6442-030
E1	TERMINAL	547-5305-002
E2	TERMINAL	304-2800-000
E3	TERMINAL	304 2800-000
E4	TERMINAL	304-2800-000
E5	TERMINAL	304 2800-000
E6	TERMINAL	304-2800-000
E7	TERMINAL	304 2800-000
E8	TERMINAL	304-0116-000
E9	TERMINAL	304 0116-000
E10	TERMINAL	304-1089-000
E11	TERMINAL	304-0116-000
E12	TERMINAL	304 0116-000
F1	FUSE	2ASB
F2	FUSE	3A 264-0297-000
FL1	FILTER, LP	673-1162-020
HT1	HEATSINK	015-3612-010
HT2	HEATSINK	015-3612-020
J1	CONNECTOR	365-0034-000
J2	BNC CONNECTOR	357-9248-010
J3	BNC CONNECTOR	357 9248-010
J4	BNC CONNECTOR	357-9248-010
J5	CONNECTOR	357-7109-000
J6	CONNECTOR	357 7109-000
J7	CONNECTOR	357-7109-000
P2	TNC CONNECTOR	357-9666-000
P3	TNC CONNECTOR	357 9666-000
P4	TNC CONNECTOR	357-9666-000
Q1	TRANSISTOR	2N3054 352-0581-010

D-2041 (9-65)

parts list

SYMBOL	DESCRIPTION	COLLINS PART NUMBER	
Q2	TRANSISTOR	2N3055	
R1	RESISTOR, VARIABLE	5 K	
R2	RESISTOR, VARIABLE	10 K	
R3	RESISTOR	0.1	
R4	RESISTOR	68.1 K	3 W
R5	RESISTOR	1.5	1 W
R6	RESISTOR	10	10 W
R7	RESISTOR	10	10 W
R8	RESISTOR	22	1 W
R9	RESISTOR	3.83 K	1/2 W
R10	RESISTOR	464	1/2 W
R11	RESISTOR	2700	1 W
R12	RESISTOR	2.2 K	1/4 W
R13	RESISTOR	47 K	1/4 W
S1	SWITCH		
S2	SWITCH MODE		
S3	SWITCH METER		
T1	TRANSFORMER POWER		
TB1	TERMINAL BOARD		
U1	REGULATOR	7824KC	
U2	REGULATOR	7824KC	
XF1	FUSEHOLDER		
XF2	FUSEHOLDER		
XFL1	SOCKET		
XQ1	SOCKET	T0-66	
XQ2	SOCKET	T0-3	
XU1	SOCKET	T0-3	
XU2	SOCKET	T0-3	
		352-0583-010	
		376-2487-000	
		380-2264-000	
		747-5115-000	
		705-7184-000	
		747-8531-000	
		747-8954-000	
		747-8954-000	
		745-3282-000	
		705-7124-000	
		705-7080-000	
		745-3370-000	
		745-0761-000	
		745-0809-000	
		266-5376-010	
		359-9475-130	
		359-9475-310	
		662-0318-010	
		367-0024-000	
		351-1120-040	
		351 1120-040	
		265-1171-000	
		265 1171-000	
		220-1005-000	
		220-0968-020	
		220-0968-010	
		220 0968-010	
		220-0968-010	

D-2041 (9-65)

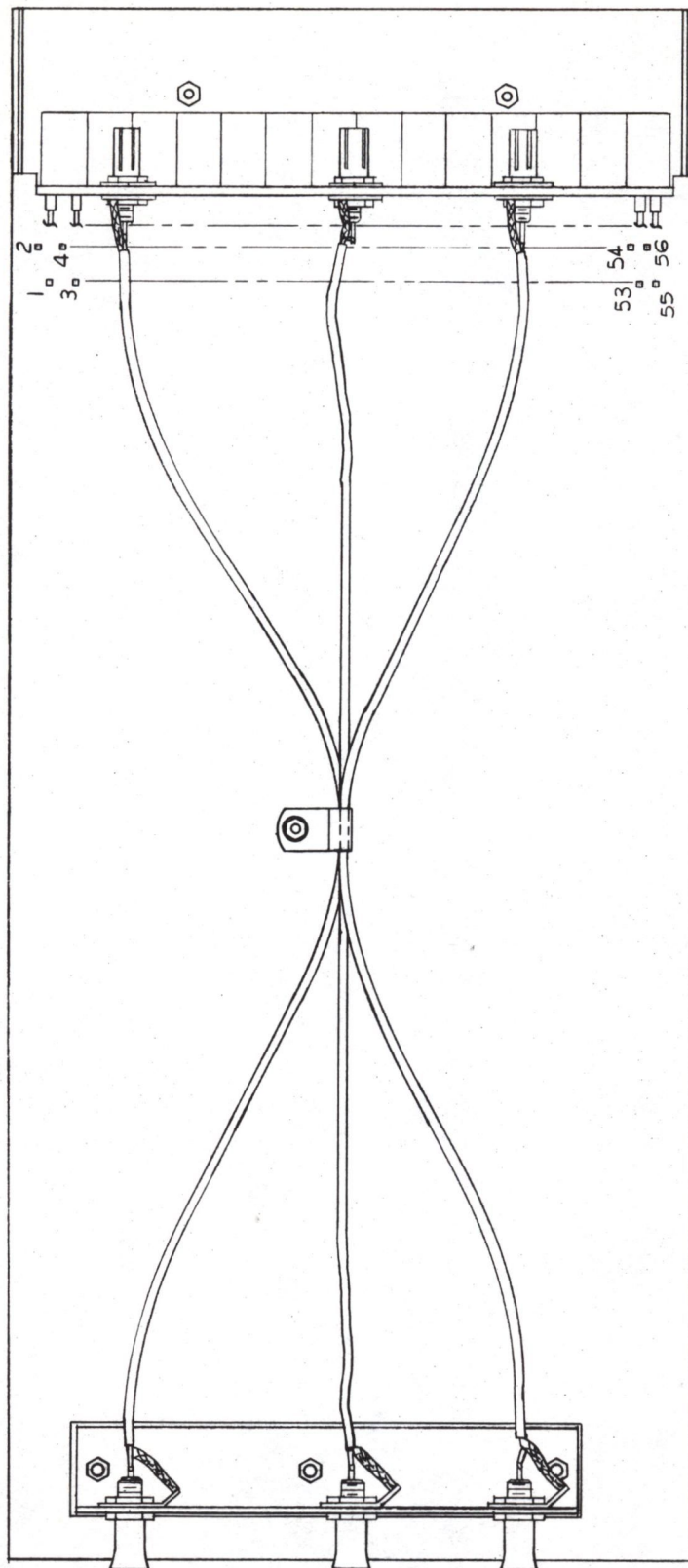

Figure 6-4. Extender Board.

B700 3267 Rp

parts list

SYMBOL	DESCRIPTION	COLLINS PART NUMBER
EXTENDER BOARD		781-5365-001
J1	CONNECTOR	357-9210-000
J2	CONNECTOR	357 9210-000
J3	CONNECTOR	357-9210-000
J4	CONNECTOR	357-9211-000
J5	CONNECTOR	357 9211-000
J6	CONNECTOR	357-9211-000
J7	CONNECTOR	372-2426-010
J8	CONNECTOR	372 2426-010
J9	CONNECTOR	372-2426-010
J10	CONNECTOR	372 2426-010
J11	CONNECTOR	372-2426-010
J12	CONNECTOR	372 2426-010
J13	CONNECTOR	372-2426-010
J14	CONNECTOR	372 2426-010
J15	CONNECTOR	372-2426-010
J16	CONNECTOR	372 2426-010
J17	CONNECTOR	372-2426-010
J18	CONNECTOR	372 2426-010
J19	CONNECTOR	372-2426-010
J20	CONNECTOR	372 2426-010

D 2041 (9 65)

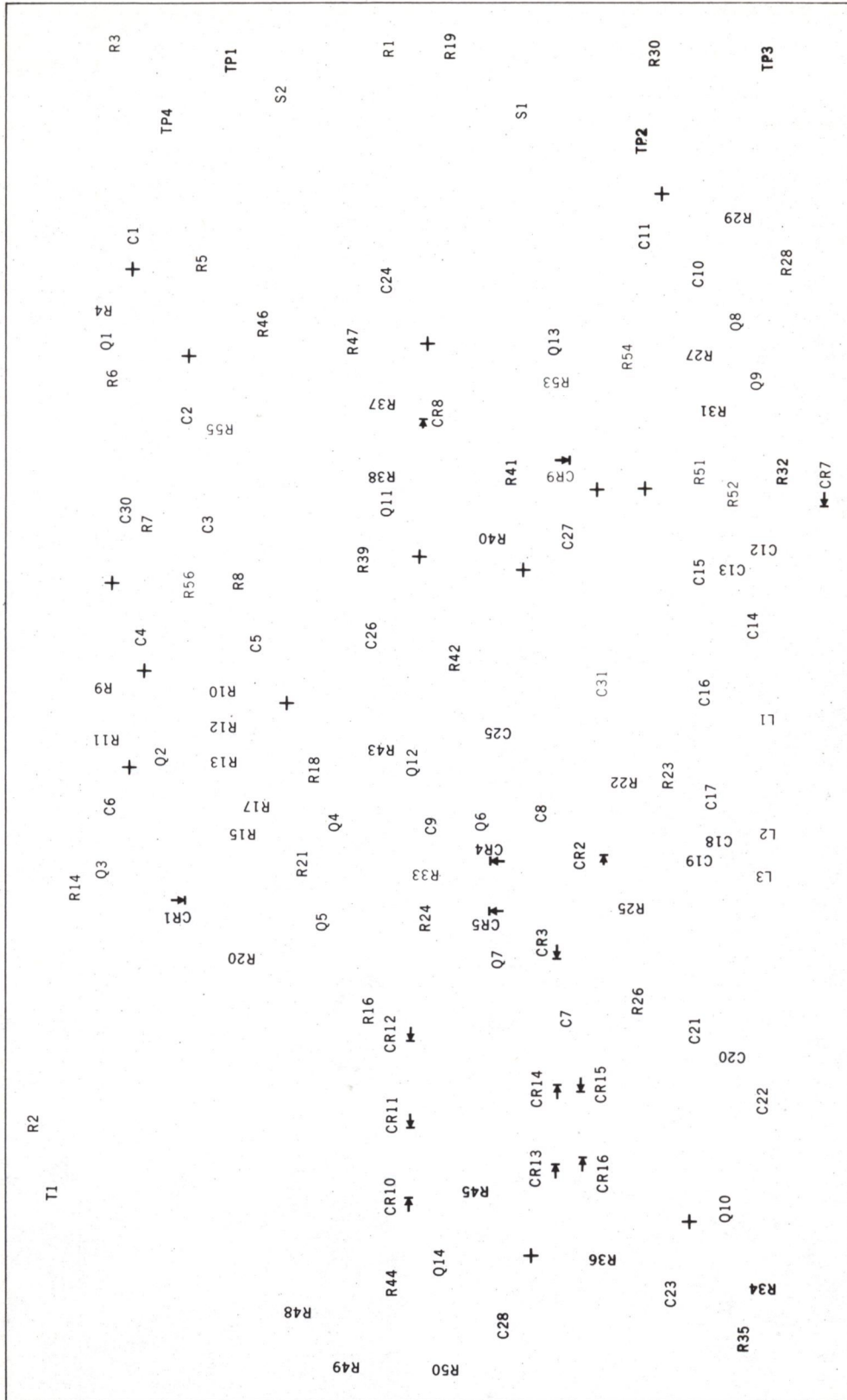

B700 3265 Rp

Figure 6-5. SCA Generator 786W-1 A1, A2.

parts list

SYMBOL	DESCRIPTION	COLLINS PART NUMBER
SCA GENERATOR 786W-1 A1,A2		772-5338-001
C1	CAPACITOR 6.8UF 35 V	184-6216-000
C2	CAPACITOR 6.8UF 35 V	184 6216-000
C3	CAPACITOR 0.022UF 50 V	933-0858-000
C4	CAPACITOR 6.8UF 35 V	184-6216-000
C5	CAPACITOR 250UF 40 V	183-2355-150
C6	CAPACITOR 6.8UF 35 V	184-6216-000
C7	CAPACITOR 3900PF 500 V	912-3046-000
C8	CAPACITOR 3900PF 500 V	912 3046-000
C9	CAPACITOR 6.8UF 35 V	184-6216-000
C10	CAPACITOR 2PF 500 V	916-0076-000
C11	CAPACITOR 6.8UF 35 V	184-6216-000
C12	CAPACITOR 500UUF 500 V	912-2977-000
C13	CAPACITOR 100PF 500 V	912-2816-000
C14	CAPACITOR 47PF 500 V	912-2792-000
C15	CAPACITOR 5PF 500 V	916-0118-000
C16	CAPACITOR 820PF 500 V	912-2995-000
C17	CAPACITOR 22PF 500 V	912-2768-000
C18	CAPACITOR 120PF 500 V	912-2822-000
C19	CAPACITOR 18PF 500 V	912-2763-000
C20	CAPACITOR 470PF 500 V	912-2974-000
C21	CAPACITOR 47PF 500 V	912-2792-000
C22	CAPACITOR 0.0075UF 75 V	184-9062-040
C23	CAPACITOR 0.033UF 100 V	184-6326-580
C24	CAPACITOR 22UF 50 V	184-6257-000
C25	CAPACITOR 250UF 40 V	183-2355-150
C26	CAPACITOR 47UF 35 V	184-6231-000
C27	CAPACITOR 5UF 50 V	183-1162-000
C28	CAPACITOR 6.8UF 35 V	184-6216-000
C29	NOT USED	
C30	CAPACITOR 15UF 35 V	184-6222-000
C31	CAPACITOR 220UF 25 V	183-2338-000
CR1	DIODE 1N914	353-2906-000
CR2	DIODE 1N995	353-2042-000
CR3	DIODE 1N995	353 2042-000
CR4	DIODE 1N995	353-2042-000
CR5	DIODE 1N995	353 2042-000
CR6	NOT USED	
CR7	DIODE 1N995	353-2042-000
CR8	DIODE 1N914	353-2906-000
CR9	DIODE 1N758	353-2723-000
CR10	DIODE 1N914	353-2906-000
CR11	DIODE 1N756A	353-2983-000
CR12	DIODE 1N756A	353 2983-000
CR13	DIODE 1N914	353-2906-000
CR14	DIODE 1N914	353 2906-000
CR15	DIODE 1N914	353-2906-000
CR16	DIODE 1N754A	353-2981-000
E1	TERMINAL	306-2222-100
E2	TERMINAL	306 2222-100
E3	TERMINAL	306-2222-100
L1	INDUCTOR 5000UH	240-0843-000
L2	INDUCTOR 1000UH	240-0839-000
L3	INDUCTOR 5000UH	240-0843-000
Q1	TRANSISTOR 2N3569	352-0629-030
Q2	TRANSISTOR 2N3565	352-0638-010
Q3	TRANSISTOR 2N718A	352-0318-000
Q4	TRANSISTOR 2N3638A	352-0636-020
Q5	TRANSISTOR 2N3638A	352 0636-020
Q6	TRANSISTOR 2N3563	352-0630-010
Q7	TRANSISTOR 2N3563	352 0630-010
Q8	TRANSISTOR 2N3563	352-0630-010
Q9	TRANSISTOR 2N3646	352-0680-010
Q10	TRANSISTOR 2N3565	352-0638-010
Q11	TRANSISTOR 2N3643	352-0713-030
Q12	TRANSISTOR 2N3643	352 0713-030
Q13	TRANSISTOR 2N3643	352-0713-030

D-2041 10-651

SYMBOL	DESCRIPTION			COLLINS PART NUMBER
Q14	TRANSISTOR	2N3643		352 0713-030
R1	RESISTOR	50 K	3/4 W	382-0012-130
R2	RESISTOR	4700	1/4 W	745-0773-000
R3	RESISTOR	5 K	3/4 W	382-0012-090
R4	RESISTOR	39 K	1/4 W	745-0806-000
R5	RESISTOR	56 K	1/4 W	745-0812-000
R6	RESISTOR	1 K	1/4 W	745-0749-000
R7	RESISTOR	6800	1/4 W	745-0779-000
R8	RESISTOR	820	1/4 W	745-0746-000
R9	RESISTOR	39 K	1/4 W	745-0806-000
R10	RESISTOR	4700	1/4 W	745-0773-000
R11	RESISTOR	3900	1/4 W	745-0770-000
R12	RESISTOR	390	1/4 W	745-0734-000
R13	RESISTOR	270	1/4 W	745-0728-000
R14	RESISTOR	7500	1/2 W	705-7138-000
R15	RESISTOR	6190	1/2 W	705-7134-000
R16	RESISTOR	1780	1/2 W	705-7108-000
R17	RESISTOR	2.15 K	1/2 W	705-7112-000
R18	RESISTOR	33 K	1/4 W	745-0803-000
R19	RESISTOR	5 K	3/4 W	382-0012-090
R20	RESISTOR	2.15 K	1/2 W	705-7112-000
R21	RESISTOR	33 K	1/4 W	745-0803-000
R22	RESISTOR	10 K	1/4 W	745-0785-000
R23	RESISTOR	1 K	1/4 W	745-0749-000
R24	RESISTOR	1.96 K	1/4 W	705-6610-000
R25	RESISTOR	1 K	1/4 W	745-0749-000
R26	RESISTOR	10 K	1/4 W	745-0785-000
R27	RESISTOR	27 K	1/4 W	745-0800-000
R28	RESISTOR	10 K	1/4 W	745-0785-000
R29	RESISTOR	470	1/4 W	745-0737-000
R30	RESISTOR	50 K	3/4 W	382-0012-130
R31	RESISTOR	3300	1/4 W	745-0767-000
R32	RESISTOR	1800	1/4 W	745-0758-000
R33	RESISTOR	1.62 K	1/4 W	705-6606-000
R34	RESISTOR	3900	1/4 W	745-0770-000
R35	RESISTOR	8200	1/4 W	745-0782-000
R36	RESISTOR	820	1/4 W	745-0746-000
R37	RESISTOR	10 K	1/4 W	745-0785-000
R38	RESISTOR	220 K	1/4 W	745-0833-000
R39	RESISTOR	2700	1/4 W	745-0764-000
R40	RESISTOR	68	1/4 W	745-0707-000
R41	RESISTOR	33	1/4 W	745-0695-000
R42	RESISTOR	10 K	1/4 W	745-0785-000
R43	RESISTOR	61.9 K	1/4 W	705-6682-000
R44	RESISTOR	180	1/4 W	745-0722-000
R45	RESISTOR	180	1/2 W	745-1321-000
R46	RESISTOR	82.5 K	1/4 W	705-6688-000
R47	RESISTOR	26.1	1/4 W	705-6664-000
R48	RESISTOR	5110	1/2 W	705-7130-000
R49	RESISTOR	5110	1/2 W	705 7130-000
R50	RESISTOR	1330	1/2 W	705-7102-000
R51	RESISTOR	1800	1/4 W	745-0758-000
R52	RESISTOR	3900	1/4 W	745-0770-000
R53	SELECT R53 FROM THE FOLLOWING LIST			
	RESISTOR	100 K	1/4 W	705-6692-000
	RESISTOR	121 K	1/4 W	705-6696-000
	RESISTOR	147 K	1/4 W	705-6700-000
	RESISTOR	178 K	1/4 W	705-6704-000
	RESISTOR	215 K	1/4 W	705-6708-000
	RESISTOR	274 K	1/4 W	705-6713-000
	RESISTOR	348 K	1/4 W	705-6718-000
	RESISTOR	422 K	1/4 W	705-6722-000
	RESISTOR	511 K	1/4 W	705-6726-000
	RESISTOR	619 K	1/4 W	705-6730-000
	RESISTOR	750 K	1/4 W	705-6734-000
R54	RESISTOR	6800	1/4 W	745-0779-000
R55	RESISTOR	3300	1/4 W	745-0767-000
R56	RESISTOR	10 K	1/4 W	745-0785-000

D-2041-19-851

parts list

SYMBOL	DESCRIPTION	COLLINS PART NUMBER
S1	SWITCH, TOGGLE	266-5321-980
S2	SWITCH, TOGGLE	266 5321-980
T1	TRANSFORMER, AF	667-0187-020
TP1	JACK, TIP	360-0434-100
TP2	JACK, TIP	360 0434-100
TP3	JACK, TIP	360-0434-100
TP4	JACK, TIP	360-0434-010

D 2041 (9-65)

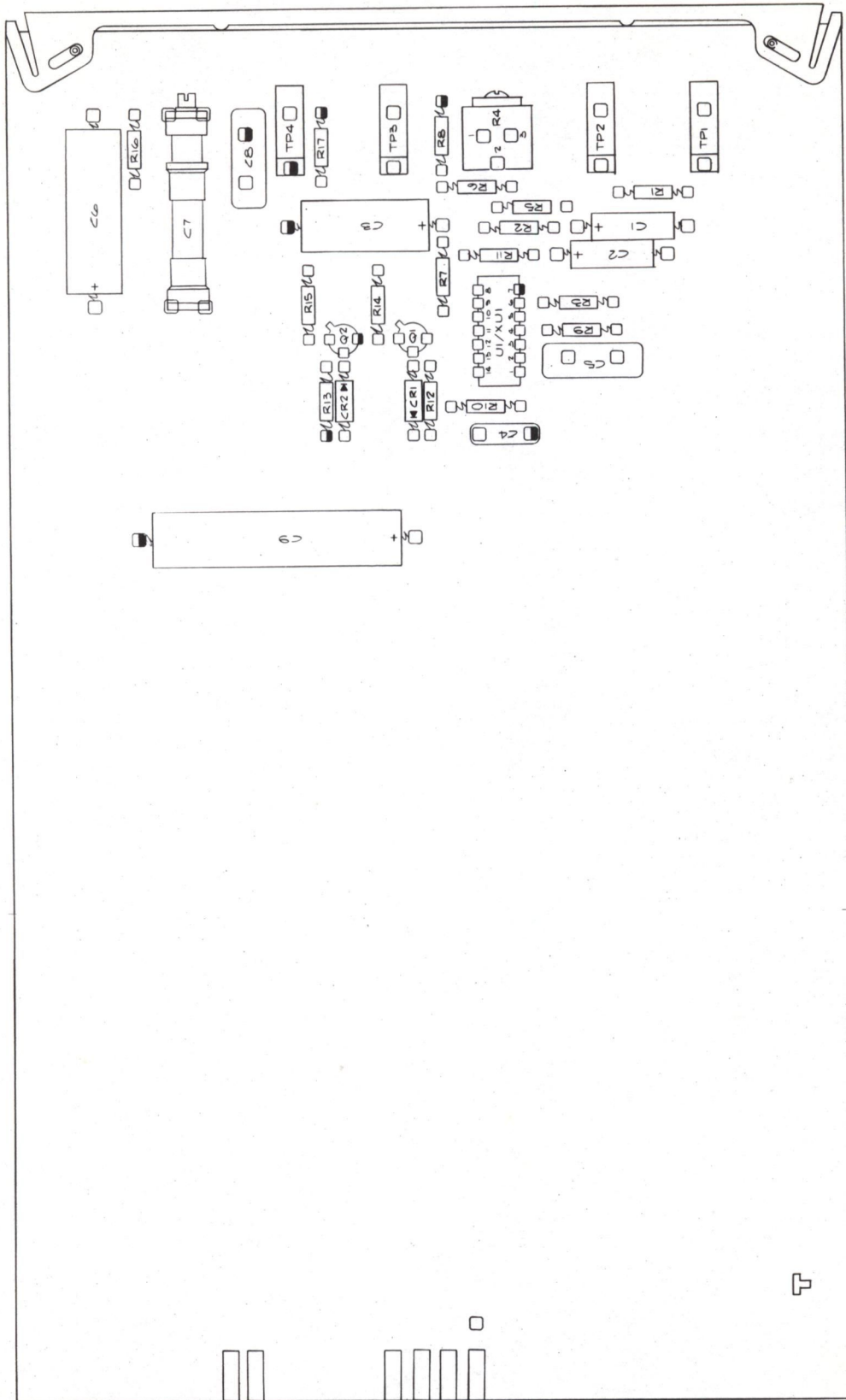

B700 3264 Rp

Figure 6-6. STL Interface 785E-1 A3.

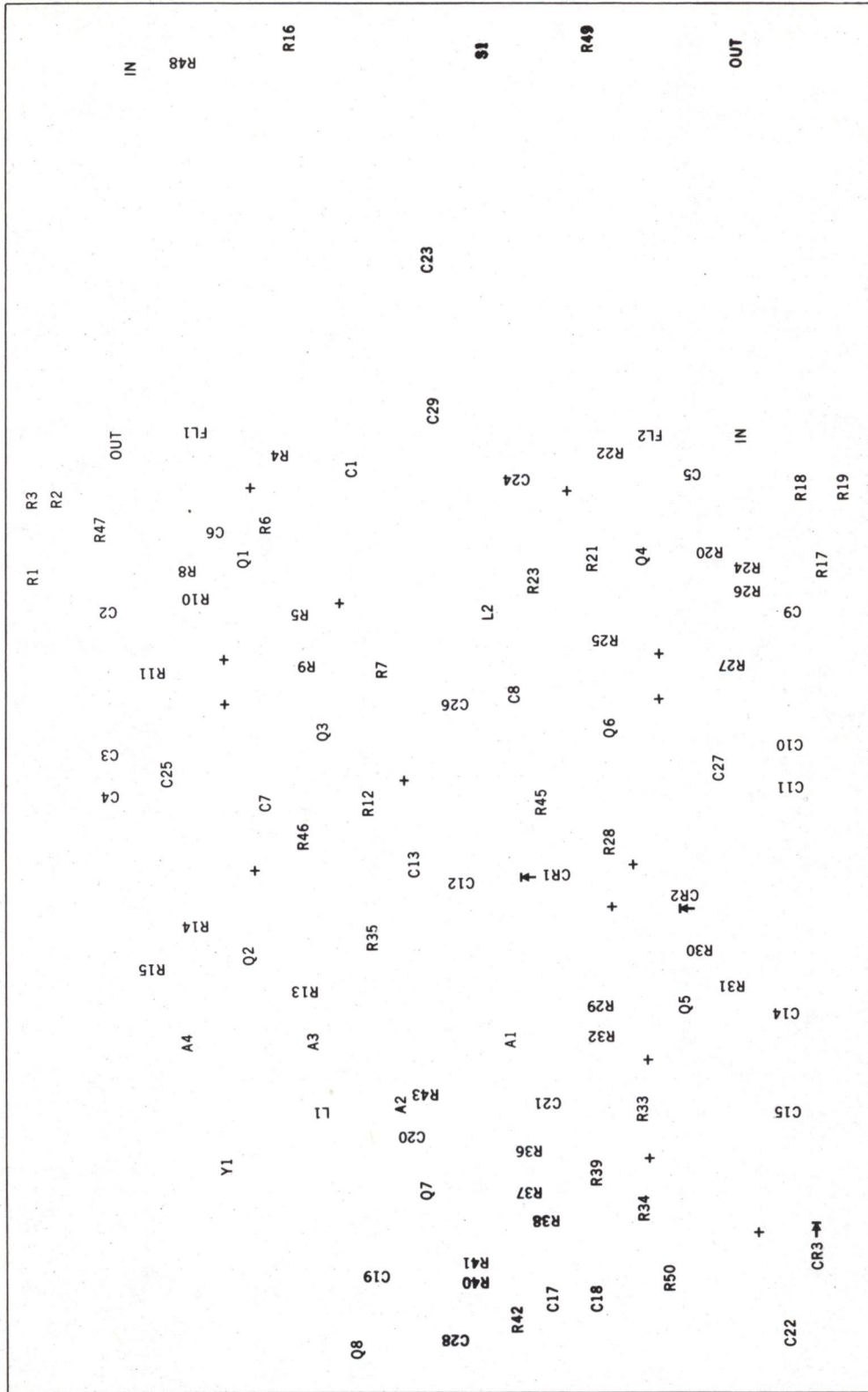

B700 3266 Rp

Figure 6-7. Stereo Generator 786V-1 A3.

parts list

SYMBOL	DESCRIPTION	COLLINS PART NUMBER
STEREO GENERATOR 786V-1 A3		783-6648-001
A1	INTEGRATED CIRCUIT ML923	351-7121-010
A2	INTEGRATED CIRCUIT ML900	351-7121-030
A3	INTEGRATED CIRCUIT ML900	351 7121-030
A4	INTEGRATED CIRCUIT ML923	351-7121-010
C1	CAPACITOR 47 UF 35 V	184-6231-000
C2	CAPACITOR 47 UF 35 V	184 6231-000
C3	CAPACITOR 47 UF 35 V	184-6231-000
C4	CAPACITOR 1000 UF 16 V	183-2355-090
C5	CAPACITOR 47 UF 35 V	184-6231-000
C6	CAPACITOR 47 UF 35 V	184 6231-000
C7	CAPACITOR 1000 PF 500 V	912-3001-000
C8	CAPACITOR 1000 PF 500 V	912 3001-000
C9	CAPACITOR 47 UF 35 V	184-6231-000
C10	CAPACITOR 47 UF 35 V	184 6231-000
C11	CAPACITOR 1000 UF 16 V	183-2355-090
C12	CAPACITOR 250 UF 40 V	183-2355-150
C13	CAPACITOR 22 UF 35 V	184-6225-000
C14	CAPACITOR 250 UF 40 V	183-2355-150
C15	CAPACITOR 250 UF 40 V	183 2355-150
C16	NOT USED	
C17	CAPACITOR 2.2 UF 25 V	913-3812-000
C18	CAPACITOR 2.2 UF 25 V	913 3812-000
C19	CAPACITOR 33 PF 500 V	912-2780-000
C20	CAPACITOR 820 PF 500 V	912-2995-000
C21	CAPACITOR 3300 PF 500 V	912-3040-000
C22	CAPACITOR 47 UF 35 V	184-6231-000
C23	CAPACITOR 30,000 PF 500 V	912-3131-000
C24	CAPACITOR 3900 PF 500 V	912-3044-000
C25	CAPACITOR 2.2 UF 25 V	913-3812-000
C26	CAPACITOR 33 PF 500 V	912-2780-000
C27	CAPACITOR 2.2 UF 25 V	913-3812-000
C28	CAPACITOR 47 PF 500 V	912-2792-000
C29	CAPACITOR 1800 PF 500 V	912-3018-000
CR1	DIODE 1N914	353-2906-000
CR2	DIODE 1N914	353 2906-000
CR3	DIODE 1N747A	353-2702-000
FL1	FILTER, LOW PASS 15 KHZ	673-1167-010
FL2	FILTER, LOW PASS 15 KHZ	673 1167-010
L1	CHOKER, RF 6800 MH	240-2560-000
L2	COIL, RF 2 MH	240-0882-010
Q1	TRANSISTOR 2N3643	352-0713-030
Q2	TRANSISTOR 2N3643	352 0713-030
Q3	TRANSISTOR 2N3153	352-0776-010
Q4	TRANSISTOR 2N3643	352-0713-030
Q5	TRANSISTOR 2N3643	352 0713-030
Q6	TRANSISTOR 2N3153	352-0776-010
Q7	TRANSISTOR 2N3643	352-0713-030
Q8	TRANSISTOR 2N3643	352 0713-030
R1	RESISTOR 226 1/8 W	705-0965-000
R2	RESISTOR 226 1/8 W	705 0965-000
R3	RESISTOR 681 1/8 W	705-0988-000
R4	RESISTOR 649 1/8 W	705-0987-000
R5	RESISTOR 22 K 1/4 W	745-0797-000
R6	RESISTOR 100 1/8 W	705-0948-000
R7	RESISTOR 22 K 1/4 W	745-0797-000
R8	RESISTOR 3300 1/4 W	745-0767-000
R9	RESISTOR 10 K 1/8 W	705-1044-000
R10	RESISTOR 464 1/8 W	705-0980-000
R11	RESISTOR 61.9 1/8 W	705-0938-000
R12	RESISTOR 1 K 1/2 W	382-0008-070
R13	RESISTOR 120 K 1/4 W	745-0824-000
R14	RESISTOR 21.5 K 1/8 W	705-1060-000
R15	RESISTOR 348 1/8 W	705-0974-000
R16	RESISTOR 20 K 1/2 W	382-0008-450
R17	RESISTOR 226 1/8 W	705-0965-000
R18	RESISTOR 226 1/8 W	705 0965-000

D 2041 19 851

SYMBOL	DESCRIPTION	COLLINS PART NUMBER
R19	RESISTOR 681	1/8 W 705-0988-000
R20	RESISTOR 649	1/8 W 705-0987-000
R21	RESISTOR 22 K	1/4 W 745-0797-000
R22	RESISTOR 100	1/8 W 705-0948-000
R23	RESISTOR 22 K	1/4 W 745-0797-000
R24	RESISTOR 3300	1/4 W 745-0767-000
R25	RESISTOR 10 K	1/8 W 705-1044-000
R26	RESISTOR 464	1/8 W 705-0980-000
R27	RESISTOR 61.9	1/8 W 705-0938-000
R28	RESISTOR 1 K	1/2 W 382-0008-070
R29	RESISTOR 120 K	1/4 W 745-0824-000
R30	RESISTOR 21.5 K	1/8 W 705-1060-000
R31	RESISTOR 348	1/8 W 705-0974-000
R32	RESISTOR 619	1/4 W 705-6586-000
R33	RESISTOR 560	1/4 W 745-0740-000
R34	RESISTOR 56	1/4 W 745-0704-000
R35	RESISTOR 470	1/4 W 745-0737-000
R36	RESISTOR 10 K	1/4 W 745-0785-000
R37	RESISTOR 68 K	1/4 W 745-0815-000
R38	RESISTOR 100	1/4 W 745-0713-000
R39	RESISTOR 820	1/4 W 745-0746-000
R40	RESISTOR 100 K	1/4 W 745-0821-000
R41	RESISTOR 3900	1/4 W 745-0770-000
R42	RESISTOR 470	1/4 W 745-0737-000
R43	RESISTOR 680	1/4 W 745-0743-000
R44	NOT USED	
R45	RESISTOR 147	1/8 W 705-0956-000
R46	RESISTOR 147	1/8 W 705 0956-000
R47	RESISTOR 470	1/4 W 745-0737-000
R48	RESISTOR 330	1/4 W 745-0731-000
R49	RESISTOR 50	1/2 W 382-0008-370
R50	RESISTOR 180	2 W 745-5621-000
S1	SWITCH, TOGGLE	266-5059-000
XY1	SOCKET, CRYSTAL	292-0215-000
Y1	CRYSTAL UNIT, QUARTZ	289-7095-020

D-2041 (9-65)

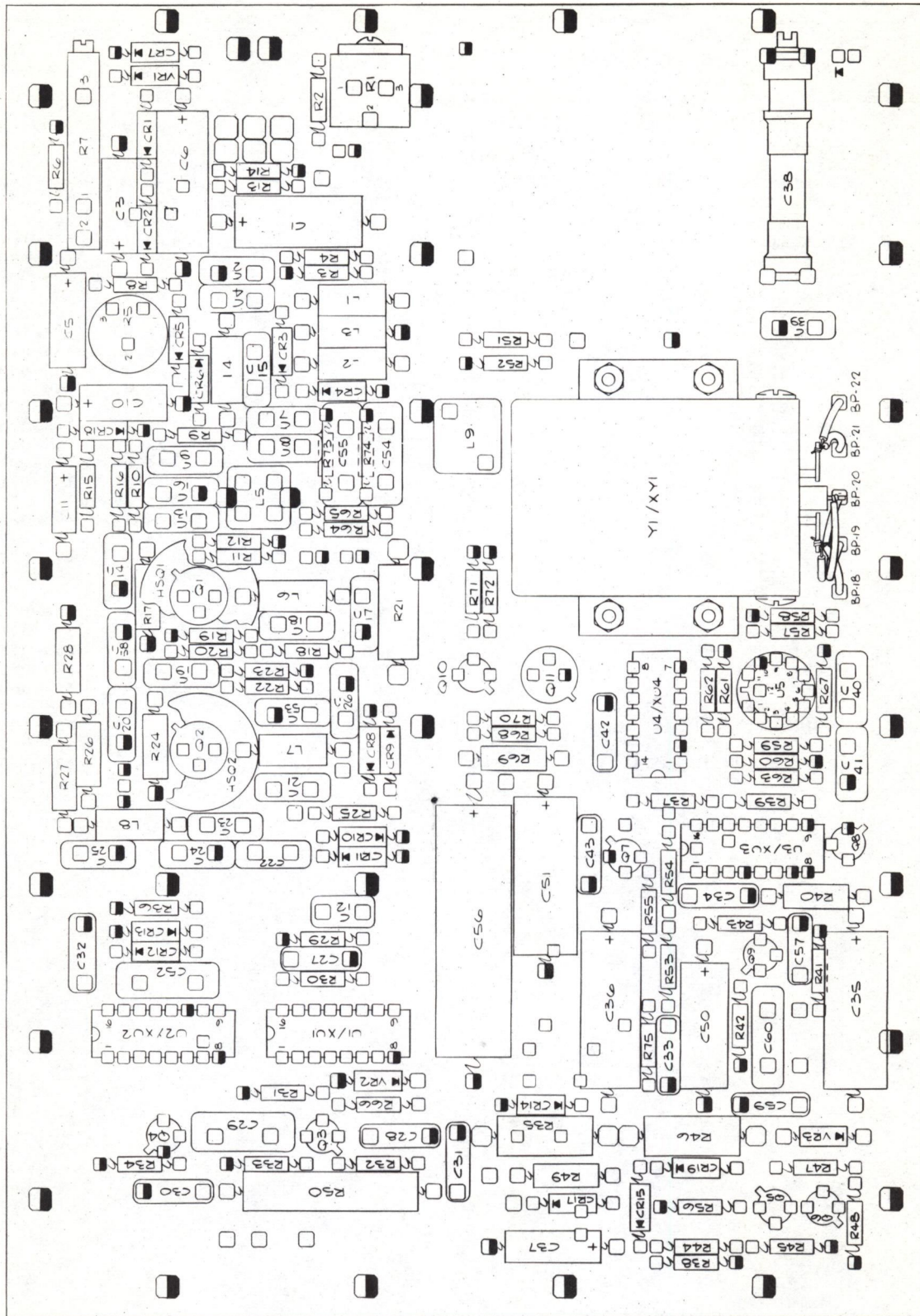

B700 3263 Rp

Figure 6-8. Modulator/Exciter A4 (Sheet 1 of 2).

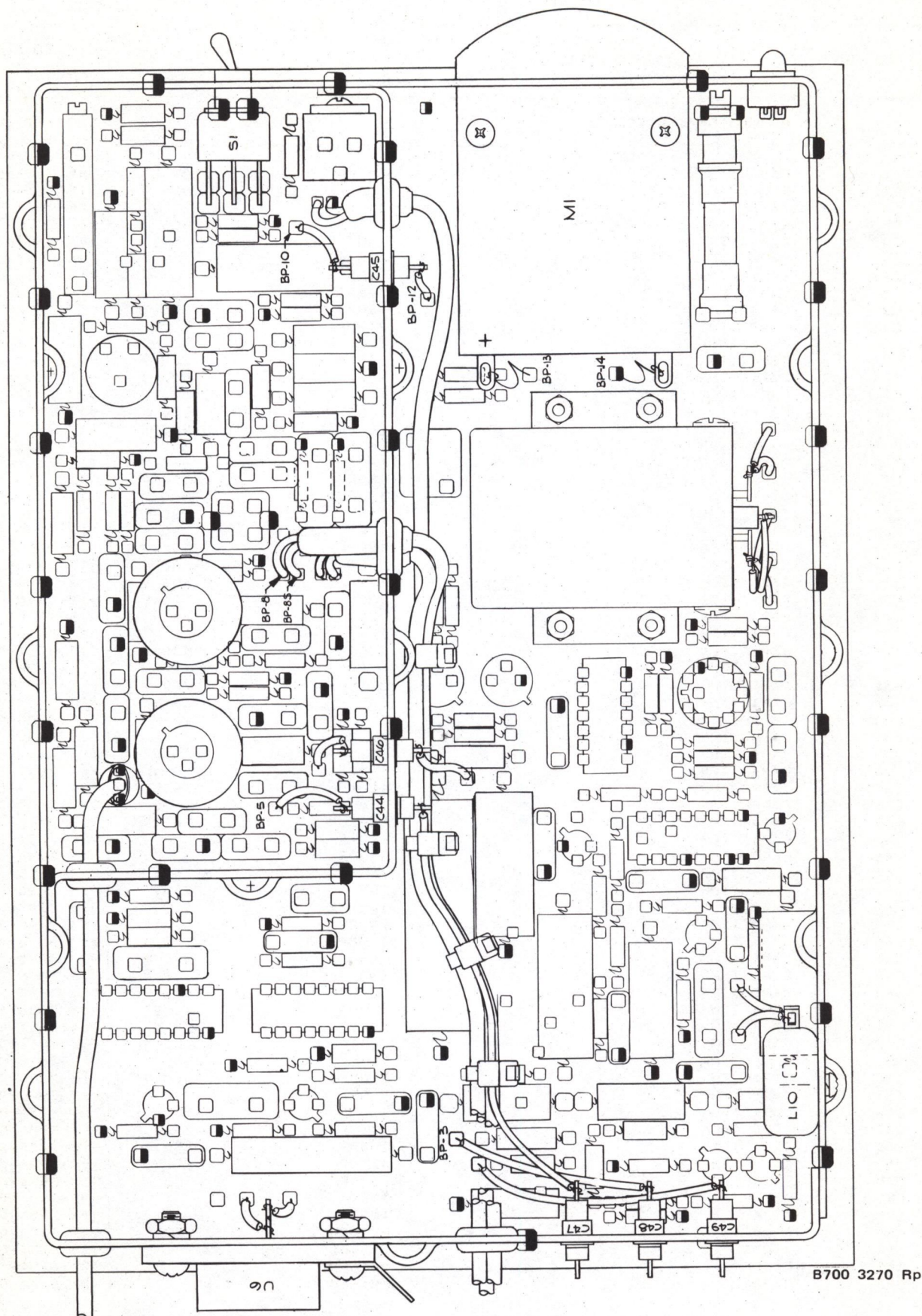

Figure 6-9. Modulator/Exciter A4 (Sheet 2 of 2).

parts list

SYMBOL	DESCRIPTION	COLLINS PART NUMBER
MODULATOR/EXCITER A4		627-6695-001
C1	CAPACITOR 100UF 25 V	184-9103-570
C2	CAPACITOR 100PF 500 V	912-2816-000
C3	CAPACITOR 10UF 25 V	184-9103-530
C4	CAPACITOR 100PF 500 V	912-2816-000
C5	CAPACITOR 10UF 25 V	184-9103-530
C6	CAPACITOR 100UF 25 V	184-9103-570
C7	CAPACITOR 51PF 500 V	916-0476-000
C8	CAPACITOR 22PF 500 V	916-0432-000
C9	CAPACITOR 47PF 500 V	912-2792-000
C10	CAPACITOR 2.2UF 50 V	184-9087-500
C11	CAPACITOR 1UF 50 V	184-9087-440
C12	CAPACITOR 220PF 500 V	912-2840-000
C13	CAPACITOR 47PF 500 V	912-2792-000
C14	CAPACITOR 47PF 500 V	912 2792-000
C15	CAPACITOR 100PF 500 V	912-2816-000
C16	CAPACITOR 100PF 500 V	912 2816-000
C17	CAPACITOR 100PF 500 V	912-2816-000
C18	CAPACITOR 18PF 500 V	912-2762-000
C19	CAPACITOR 100PF 500 V	912-2816-000
C20	CAPACITOR 100PF 500 V	912 2816-000
C21	CAPACITOR 5PF 500 V	912-2751-000
C22	CAPACITOR 5PF 500 V	912 2751-000
C23	CAPACITOR 100PF 500 V	912-2816-000
C24	CAPACITOR 22PF 500 V	912-2768-000
C25	CAPACITOR 39PF 500 V	912-2786-000
C26	CAPACITOR 100PF 500 V	912-2816-000
C27	CAPACITOR 1UF 25 V	913-3810-000
C28	CAPACITOR 1UF 25 V	913 3810-000
C29	CAPACITOR 1000PF 500 V	912-3001-000
C30	CAPACITOR 0.1UF 25 V	912-3806-000
C31	CAPACITOR 0.1UF 200 V	913-3681-000
C32	CAPACITOR 1UF 25 V	913-3810-000
C33	CAPACITOR 0.1UF 25 V	912-3806-000
C34	CAPACITOR 0.1UF 25 V	912 3806-000
C35	CAPACITOR 180UF 25 V	184-8664-000
C36	CAPACITOR 180UF 25 V	184 8664-000
C37	CAPACITOR 10UF 25 V	184-9103-530
C38	CAPACITOR 1-60PF 1000V	922-0609-000
C39	CAPACITOR 18PF 500 V	912-2762-000
C40	CAPACITOR 180PF 500 V	912-2834-000
C41	CAPACITOR 180PF 500 V	912 2834-000
C42	CAPACITOR 1UF 25 V	913-3810-000
C43	CAPACITOR 1UF 25 V	913 3810-000
C44	CAPACITOR 1000PF 500 V	913-3208-000
C45	CAPACITOR 1000PF 500 V	913 3208-000
C46	CAPACITOR 1000PF 500 V	913-3208-000
C47	CAPACITOR 1000PF 500 V	913 3208-000
C48	CAPACITOR 1000PF 500 V	913-3208-000
C49	CAPACITOR 1000PF 500 V	913 3208-000
C50	CAPACITOR 100UF 10 V	184-9086-610
C51	CAPACITOR 180UF 25 V	184-8664-000
C52	CAPACITOR 1000PF 500 V	912-3001-000
C53	CAPACITOR 100PF 500 V	912-2816-000
C54	CAPACITOR 510PF 500 V	912-2980-000
C55	CAPACITOR 510PF 500 V	912 2980-000
C56	CAPACITOR 100UF 50 V	183-1281-080
C57	CAPACITOR 0.1UF 25 V	912-3806-000
C58	CAPACITOR 100PF 500 V	912-2816-000
C59	CAPACITOR 0.1UF 25 V	912-3806-000
C60	CAPACITOR 560PF 500 V	912-2983-000
CR1	DIODE 1N914	353-2906-000
CR2	DIODE 1N914	353 2906-000
CR3	DIODE MV1404	922-6100-020
CR4	DIODE MV1404	922 6100-020
CR5	DIODE MV1650	922-6109-020
CR6	DIODE MV1650	922 6109-020

D-2041 (9-65)

SYMBOL	DESCRIPTION	COLLINS PART NUMBER
CR7	DIODE	1N914 353-2906-000
CR8	DIODE	1N914 353 2906-000
CR9	DIODE	1N914 353-2906-000
CR10	DIODE	1N914 353 2906-000
CR11	DIODE	1N914 353-2906-000
CR12	DIODE	1N914 353 2906-000
CR13	DIODE	1N914 353-2906-000
CR14	DIODE	1N914 353 2906-000
CR15	DIODE	1N914 353-2906-000
CR16	DIODE	353-3725-060
CR17	DIODE	1N914 353-2906-000
CR18	DIODE	1N5159 353-6549-020
CR19	DIODE	1N914 353-2906-000
HSQ1	HEATSINK	352-2619-030
HSQ2	HEATSINK	352 2619-030
L1	INDUCTOR	1.5 UHY 240-2715-150
L2	INDUCTOR	1.5 UHY 240 2715-150
L3	INDUCTOR	1.5 UHY 240-2715-150
L4	INDUCTOR	1.5 UHY 240 2715-150
L5	INDUCTOR, VARIABLE	0.13 UHY 242-0424-050
L6	INDUCTOR	0.47 UHY 240-2715-090
L7	INDUCTOR	1.5 UHY 240-2715-150
L8	INDUCTOR	0.1 UHY 240-2715-010
L9	INDUCTOR	10 HY 678-0205-010
L10	INDUCTOR	150 MHY 240-0276-000
M1	METER	0-50 UA 458-0908-020
P1	CONNECTOR BOARD	627-9766-001
P2	CONNECTOR	357-9210-000
Q1	TRANSISTOR	2N5109 352-0766-010
Q2	TRANSISTOR	2N5109 352 0766-010
Q3	TRANSISTOR	2N2907A 352-0551-013
Q4	TRANSISTOR	2N2222A 352-0661-023
Q5	TRANSISTOR	2N2222A 352 0661-023
Q6	TRANSISTOR	2N2222A 352-0661-023
Q7	TRANSISTOR	2N2222A 352 0661-023
Q8	TRANSISTOR	2N2222A 352-0661-023
Q9	TRANSISTOR	2N2222A 352 0661-023
Q10	TRANSISTOR	2N2222A 352-0661-023
Q11	TRANSISTOR	2N3053 352-0613-010
R1	RESISTOR, VARIABLE	500 376-0254-030
R2	RESISTOR	100 1/4 W 745-0713-000
R3	RESISTOR	22 K 1/4 W 745-0797-000
R4	RESISTOR	47 K 1/4 W 745-0809-000
R5	RESISTOR, VARIABLE	25 K 380-3761-080
R6	RESISTOR	22 K 1/4 W 745-0797-000
R7	RESISTOR, VARIABLE	10 K 3/4 W 381-1802-000
R8	RESISTOR	22 K 1/4 W 745-0797-000
R9	RESISTOR	22 K 1/4 W 745 0797-000
R10	RESISTOR	10 K 1/4 W 745-0785-000
R11	RESISTOR	4.7 K 1/4 W 745-0773-000
R12	RESISTOR	1 K 1/4 W 745-0749-000
R13	RESISTOR	10 K 1/4 W 745-0785-000
R14	RESISTOR	8.2 K 1/4 W 745-0782-000
R15	RESISTOR	47 K 1/4 W 745-0809-000
R16	RESISTOR	470 K 1/4 W 745-0845-000
R17	RESISTOR	100 1/2 W 745-1310-000
R18	RESISTOR	15 1/4 W 745-0683-000
R19	RESISTOR	68 1/4 W 745-0707-000
R20	RESISTOR	15 1/4 W 745-0683-000
R21	RESISTOR	150 1 W 745-3317-000
R22	RESISTOR	3.3 K 1/4 W 745-0767-000
R23	RESISTOR	470 1/4 W 745-0737-000
R24	RESISTOR	47 1/2 W 745-1296-000
R25	RESISTOR	4.7 K 1/4 W 745-0773-000
R26	RESISTOR	22 1/2 W 745-1282-000
R27	RESISTOR	22 1/2 W 745 1282-000
R28	RESISTOR	47 1/2 W 745-1296-000
R29	RESISTOR	3.9 K 1/4 W 745-0770-000
R30	RESISTOR	1.2 K 1/4 W 745-0752-000

D-2041 (9-65)

parts list

SYMBOL	DESCRIPTION	COLLINS PART NUMBER
R31	RESISTOR	470 1/4 W 745-0737-000
R32	RESISTOR	100 1/4 W 745-0713-000
R33	RESISTOR	270 1/4 W 745-0728-000
R34	RESISTOR	1 K 1/4 W 745-0749-000
R35	RESISTOR	220 1 W 745-3324-000
R36	RESISTOR	10 K 1/4 W 745-0785-000
R37	RESISTOR	10 K 1/4 W 745 0785-000
R38	RESISTOR	1 K 1/4 W 745-0749-000
R39	RESISTOR	10 K 1/4 W 745-0785-000
R40	RESISTOR	2.2 K 1/2 W 745-1366-000
R41	RESISTOR	2.2 K 1/4 W 745-0761-000
R42	RESISTOR	470 1/4 W 745-0737-000
R43	RESISTOR	4.7 K 1/4 W 745-0773-000
R44	RESISTOR	1 K 1/4 W 745-0749-000
R45	RESISTOR	2.7 K 1/4 W 745-0764-000
R46	RESISTOR	1 K 1 W 745-3352-000
R47	RESISTOR	4.7K 1/4 W 745-0773-000
R48	RESISTOR	1 K 1/4 W 745-0749-000
R49	RESISTOR	2.7 K 1/2 W 745-1370-000
R50	RESISTOR	39 2 W 745-5593-000
R51	RESISTOR	100 K 1/4 W 745-0821-000
R52	RESISTOR	1 K 1/4 W 745-0749-000
R53	RESISTOR	10 K 1/4 W 745-0785-000
R54	RESISTOR	10 K 1/4 W 745 0785-000
R55	RESISTOR	4.7 K 1/4 W 745-0773-000
R56	RESISTOR	15 1/4 W 745-0683-000
R57	RESISTOR	10 K 1/4 W 745-0785-000
R58	RESISTOR	10 K 1/4 W 745 0785-000
R59	RESISTOR	270 1/4 W 745-0728-000
R60	RESISTOR	470 1/4 W 745-0737-000
R61	RESISTOR	470 1/4 W 745 0737-000
R62	RESISTOR	1 K 1/4 W 745-0749-000
R63	RESISTOR	1 K 1/4 W 745 0749-000
R64	RESISTOR	27 K 1/4 W 745-0800-000
R65	RESISTOR	27 K 1/4 W 745 0800-000
R66	RESISTOR	1 K 1/4 W 745-0749-000
R67	RESISTOR	100 1/4 W 745-0713-000
R68	RESISTOR	15 K 1/4 W 745-0791-000
R69	RESISTOR	1.2 K 1/2 W 745-1356-000
R70	RESISTOR	15 K 1/4 W 745-0791-000
R71	RESISTOR	2.2 K 1/4 W 745-0761-000
R72	RESISTOR	4.7 K 1/4 W 745-0773-000
R73	RESISTOR	2.2 K 1/4 W 745-0761-000
R74	RESISTOR	2.2 K 1/4 W 745 0761-000
R75	RESISTOR	15 K 1/4 W 745-0791-000
S1	SWITCH	266-5321-990
U1	INTEGRATED CIRCUIT	MC10178 351-1520-020
U2	INTEGRATED CIRCUIT	CD4020 351-8159-090
U3	INTEGRATED CIRCUIT	CD4027 351-8159-180
U4	INTEGRATED CIRCUIT	GD4024 351-8159-100
U5	INTEGRATED CIRCUIT	CA3018 351-1016-010
U6	INTEGRATED CIRCUIT	7805KC 351-1120-080
VR1	ZENER DIODE	1N4744A 353-6481-330
VR2	ZENER DIODE	1N4744A 353 6481-330
VR3	ZENER DIODE	1N4740A 353-6481-250
XCR16	RING, RETAINING	353-3725-060
XU1	SOCKET	220-0001-020
XU2	SOCKET	220 0001-020
XU3	SOCKET	220-0001-020
XU4	SOCKET	220-0001-010
XU5	INSULATOR DISC	352-9552-040
XY1	OVEN CRYSTAL	292-0328-010

D-2041 (9-65)

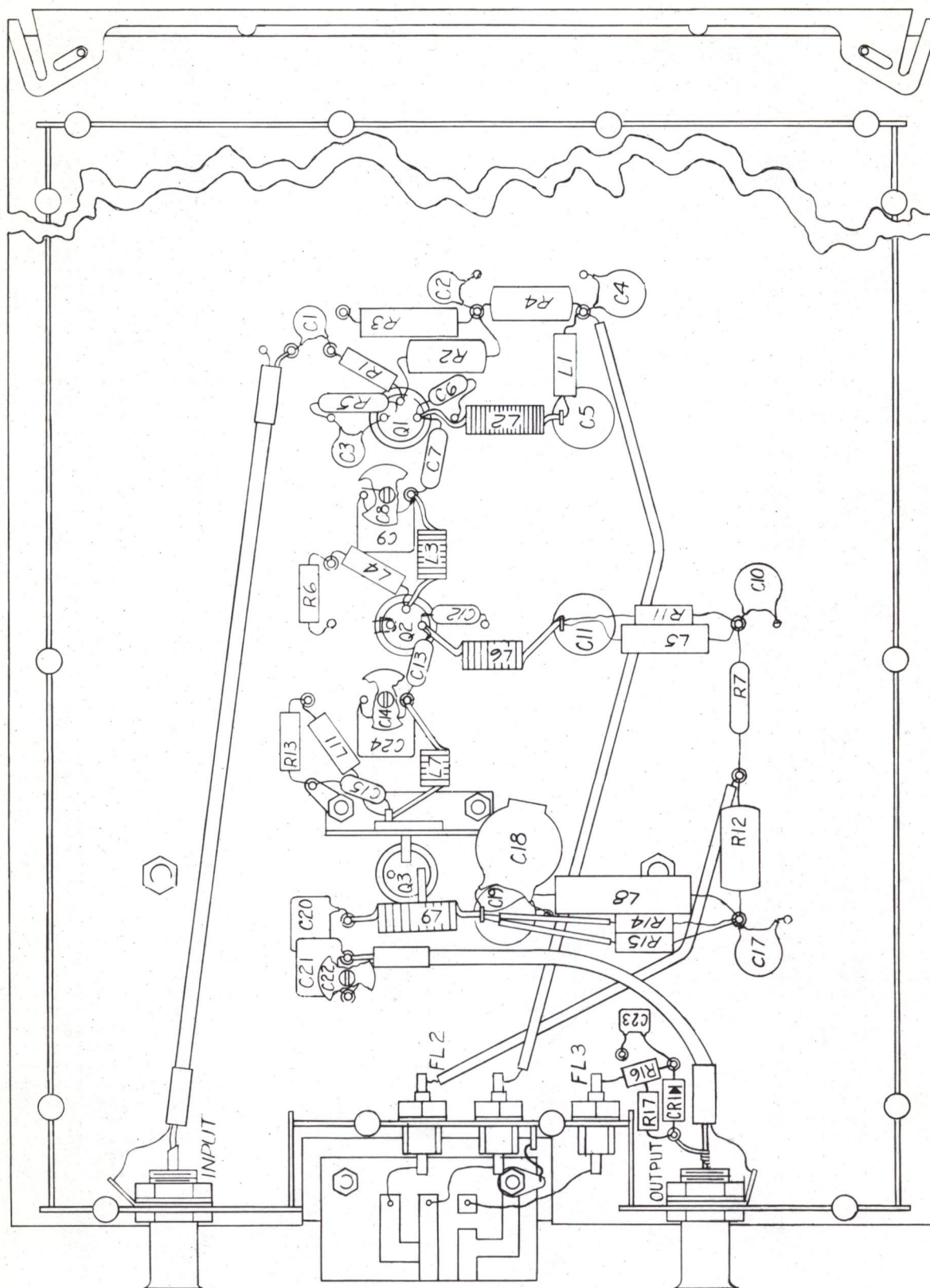

B700 3268 Rp

Figure 6-10. Power Amplifier A5.

parts list

SYMBOL	DESCRIPTION	COLLINS PART NUMBER
POWER AMPLIFIER A5		769-0830-001
C1	CAPACITOR 680PF 1000V	913-1194-000
C2	CAPACITOR 470PF 500 V	913-1189-000
C3	CAPACITOR 470PF 500 V	913 1189-000
C4	CAPACITOR 0.01UF 100 V	913-3680-000
C5	CAPACITOR 1000PF 500 V	912-4115-330
C6	CAPACITOR 15PF 500 V	912-2759-000
C7	CAPACITOR 15PF 500 V	912 2759-000
C8	CAPACITOR 5.5-18PF 350 V	917-1222-000
C9	CAPACITOR 33PF 500 V	912-2781-000
C10	CAPACITOR 0.01UF 100 V	913-3680-000
C11	CAPACITOR 1000PF 500 V	912-4115-330
C12	CAPACITOR 10PF 500 V	912-2753-000
C13	CAPACITOR 18PF 500 V	912-2762-000
C14	CAPACITOR 5.5-18PF 350 V	917-1222-000
C15	CAPACITOR 82PF 500 V	912-2810-000
C16	CAPACITOR 500PF 500 V	912-0667-000
C17	CAPACITOR 0.01UF 100 V	913-3680-000
C18	CAPACITOR 0.1PF 200 V	913-3681-000
C19	CAPACITOR 1000PF 500 V	912-4115-330
C20	CAPACITOR 110PF 500 V	912-2819-000
C21	CAPACITOR 27PF 500 V	912-2774-000
C22	CAPACITOR 5.5-18PF 350 V	917-1222-000
C23	CAPACITOR 100PF 500 V	912-2816-000
C24	CAPACITOR 22PF 500 V	912-2769-000
CR1	DIODE 1N914	353-2906-000
FL1	FILTER, RI 1300PF 200 V	241-0332-000
FL2	FILTER, RI 1300PF 200 V	241 0332-000
FL3	FILTER, RI 1300PF 200 V	241-0332-000
J1	CONNECTOR VG1051	357-9210-000
J2	CONNECTOR VG1051	357 9210-000
L1	COIL, RF 1 UH	240-1590-000
L2	COIL 0.082 UH	776-1882-001
L3	COIL 0.048 UH	776-1910-001
L4	COIL, RF 0.15 UH	240-1585-000
L5	COIL, RF 2.2 UH	240-1654-000
L6	COIL 0.056 UH	776-1911-001
L7	COIL 0.05 UH	776-1912-001
L8	CHOKER, RF 1.2 UH	240-1605-000
L9	COIL 0.092 UH	776-1883-001
L11	COIL, RF 0.15 UH	240-1585-000
Q1	TRANSISTOR 2N3866	352-0671-010
Q2	TRANSISTOR 2N3375	352-0611-010
Q3	TRANSISTOR 2N5102	352-0747-010
R1	RESISTOR 39 1/2 W	745-1293-000
R2	RESISTOR 22 3 W	747-5327-000
R3	RESISTOR 23.7 1/2 W	705-7018-000
R4	RESISTOR 270 3 W	747-5349-000
R5	RESISTOR 10 1/4 W	705-6500-000
R6	RESISTOR 100 1/2 W	745-1310-000
R7	RESISTOR 2 1 W	747-4230-300
R11	RESISTOR 10 1/2 W	745-1268-000
R12	RESISTOR 0.5 2.5 W	746-9457-000
R13	RESISTOR 4.7 1/2 W	745-6279-000
R14	RESISTOR 10 1/2 W	745-1268-000
R15	RESISTOR 10 1/2 W	745 1268-000
R16	RESISTOR 1 K 1/4 W	745-0749-000
R17	RESISTOR 470 1/4 W	745-0737-000

D-2041 (9-65)

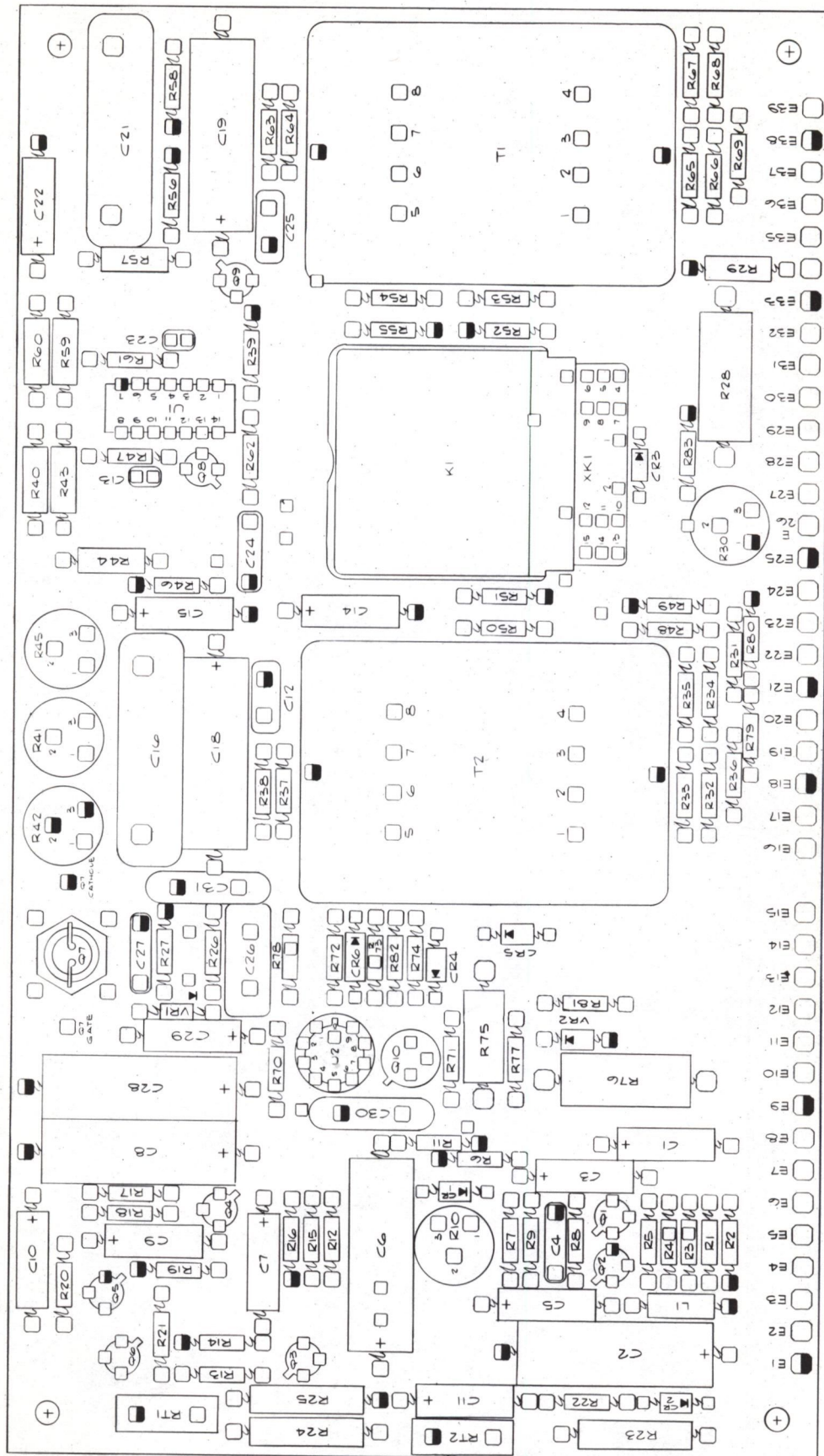

Figure 6-11. Audio/Mtr Regulator A6.

B700 3269 Rp

parts list

SYMBOL	DESCRIPTION	COLLINS PART NUMBER
AUDIO/MTR REGULATOR A6		627-9773-001
C1	CAPACITOR 22UF 15 V	184-9086-320
C2	CAPACITOR 180UF 25 V	184-8664-000
C3	CAPACITOR 22UF 15 V	184-9086-320
C4	CAPACITOR 0.1UF 25 V	913-3806-000
C5	CAPACITOR 10UF 20 V	184-9086-470
C6	CAPACITOR 150UF 30 V	184-8673-000
C7	CAPACITOR 22UF 15 V	184-9086-320
C8	CAPACITOR 180UF 25 V	184-8664-000
C9	CAPACITOR 22UF 15 V	184-9086-320
C10	CAPACITOR 22UF 15 V	184 9086-320
C11	CAPACITOR 10UF 20 V	184-9086-470
C12	CAPACITOR 100PF 500 V	912-2816-000
C13	CAPACITOR 0.01UF 50 V	913-3279-110
C14	CAPACITOR 22UF 15 V	184-9086-320
C15	CAPACITOR 22UF 15 V	184 9086-320
C16	CAPACITOR 0.030UF 500 V	912-3133-000
C17	NOT USED	
C18	CAPACITOR 180UF 25 V	184-8664-000
C19	CAPACITOR 180UF 25 V	184 8664-000
C20	NOT USED	
C21	CAPACITOR 0.030UF 500 V	912-3133-000
C22	CAPACITOR 22UF 15 V	184-9086-320
C23	CAPACITOR 0.01UF 50 V	913-3279-110
C24	CAPACITOR 1UF 25 V	913-3810-000
C25	CAPACITOR 100PF 500 V	912-2816-000
C26	CAPACITOR 2200PF 500 V	913-3025-000
C27	CAPACITOR 1UF 25 V	913-3810-000
C28	CAPACITOR 180UF 25 V	184-8664-000
C29	CAPACITOR 22UF 15 V	184-9086-320
C30	CAPACITOR 0.1UF 200 V	913-3681-000
C31	CAPACITOR 0.1UF 200 V	913 3681-000
CR1	DIODE 1N914	353-2906-000
CR2	DIODE 1N914	353 2906-000
CR3	DIODE 1N4003	353-6442-030
CR4	DIODE 1N914	353-2906-000
CR5	DIODE 1N914	353 2906-000
CR6	DIODE 1N914	353-2906-000
K1	RELAY	970-2420-040
L1	INDUCTOR 6.8 MHY	240-1578-000
Q1	TRANSISTOR 2N2907A	352-0551-013
Q2	TRANSISTOR 2N2907A	352 0551-013
Q3	TRANSISTOR 2N2907A	352-0551-013
Q4	TRANSISTOR 2N2907A	352 0551-013
Q5	TRANSISTOR 2N2907A	352-0551-013
Q6	TRANSISTOR 2N2907A	352 0551-013
Q7	TRANSISTOR, SCR 2N4168	353-6485-020
Q8	TRANSISTOR 2N2222A	352-0661-023
Q9	TRANSISTOR 2N2222A	352 0661-023
Q10	TRANSISTOR 2N3053	352-0613-010
R1	RESISTOR 8.2 K 1/4 W	745-0782-000
R2	RESISTOR 47 K 1/4 W	745-0809-000
R3	RESISTOR 1.2 K 1/4 W	745-0752-000
R4	RESISTOR 82 1/4 W	745-0710-000
R5	RESISTOR 5.6 K 1/4 W	745-0776-000
R6	RESISTOR 8.2 K 1/4 W	745-0782-000
R7	RESISTOR 5.6 K 1/4 W	745-0776-000
R8	RESISTOR 23.7 K 1/4 W	705-6662-000
R9	RESISTOR 1.2 K 1/4 W	745-0752-000
R10	RESISTOR, VARIABLE 100	380-3761-010
R11	RESISTOR 390 K 1/4 W	745-0842-000
R12	RESISTOR 5.6 K 1/4 W	745-0776-000
R13	RESISTOR 1.2 K 1/4 W	745-0752-000
R14	RESISTOR 5.6 K 1/4 W	745-0776-000
R15	RESISTOR 3.9 K 1/4 W	745-0770-000
R16	RESISTOR 12 K 1/4 W	745-0788-000
R17	RESISTOR 2.2 K 1/4 W	745-0761-000

D 2041 (9.65)

SYMBOL	DESCRIPTION	COLLINS PART NUMBER
R18	RESISTOR	10 K 1/4 W 745-0785-000
R19	RESISTOR	5.6 K 1/4 W 745-0776-000
R20	RESISTOR	22 K 1/4 W 745-0797-000
R21	RESISTOR	390 1/4 W 745-0734-000
R22	RESISTOR	1.5 K 1/4 W 745-0755-000
R23	RESISTOR	12.1 K 1/4 W 705-6648-000
R24	RESISTOR	1.78 K 1/4 W 705-1418-250
R25	RESISTOR	511 1/4 W 705-1417-690
R26	RESISTOR	100 1/4 W 745-0713-000
R27	RESISTOR	220 1/4 W 745-0725-000
R28	RESISTOR	390 2 W 745-5635-000
R29	RESISTOR	100 K 1/4 W 745-0821-000
R30	RESISTOR, VARIABLE	1 K 380 3761-040
R31	RESISTOR	22 K 1/4 W 745-0797-000
R32	RESISTOR	274 1/8 W 705-0969-000
R33	RESISTOR	274 1/8 W 705 0969-000
R34	RESISTOR	274 1/8 W 705-0969-000
R35	RESISTOR	274 1/8 W 705 0969-000
R36	RESISTOR	154 1/8 W 705-0957-000
R37	RESISTOR	2.7 K 1/4 W 745-0764-000
R38	RESISTOR	10 K 1/8 W 705-1454-630
R39	RESISTOR	10 K 1/4 W 745-0785-000
R40	RESISTOR	2.67 K 1/4 W 705-1418-420
R41	RESISTOR, VARIABLE	2.5 K 380-3761-050
R42	RESISTOR, VARIABLE	100 380-3761-010
R43	RESISTOR	4.64 K 1/4 W 705-1418-650
R44	RESISTOR	2.87 K 1/4 W 705-1418-450
R45	RESISTOR, VARIABLE	2.5 K 380-3761-200
R46	RESISTOR	1 K 1/4 W 745-0749-000
R47	RESISTOR	33 1/4 W 745-0695-000
R48	RESISTOR	12.1 K 1/8 W 705-1454-650
R49	RESISTOR	237 1/8 W 705-1454-240
R50	RESISTOR	4.22 K 1/8 W 705-1454-540
R51	RESISTOR	10 K 1/4 W 745-0785-000
R52	RESISTOR	10 K 1/4 W 745 0785-000
R53	RESISTOR	4.22 K 1/8 W 705-1454-540
R54	RESISTOR	12.1 K 1/8 W 705-1454-650
R55	RESISTOR	237 1/8 W 705-1454-240
R56	RESISTOR	1 K 1/4 W 745-0749-000
R57	RESISTOR	3.32 K 1/4 W 705-1418-510
R58	RESISTOR	100 1/4 W 745-0713-000
R59	RESISTOR	6.81 K 1/4 W 705-1418-810
R60	RESISTOR	3.32 K 1/4 W 705-1418-510
R61	RESISTOR	33 1/4 W 745-0695-000
R62	RESISTOR	10 K 1/4 W 745-0785-000
R63	RESISTOR	10 K 1/8 W 705-1454-630
R64	RESISTOR	2.7 K 1/4 W 745-0764-000
R65	RESISTOR	274 1/8 W 705-0969-000
R66	RESISTOR	274 1/8 W 705 0969-000
R67	RESISTOR	274 1/8 W 705-0969-000
R68	RESISTOR	274 1/8 W 705 0969-000
R69	RESISTOR	154 1/8 W 705-0957-000
R70	RESISTOR	1.5 K 1/4 W 745-0755-000
R71	RESISTOR	1 K 1/4 W 745-0749-000
R72	RESISTOR	10 K 1/4 W 745-0785-000
R73	RESISTOR	1 K 1/4 W 745-0749-000
R74	RESISTOR	10 K 1/4 W 745-0785-000
R75	RESISTOR	470 1 W 745-3338-000
R76	RESISTOR	100 2 W 745-5610-000
R77	RESISTOR	1.8 K 1/4 W 745-0758-000
R78	RESISTOR	100 1/4 W 745-0713-000
R79	RESISTOR	22 K 1/4 W 745-0797-000
R80	RESISTOR	39 1/4 W 745-0698-000
R81	RESISTOR	10 K 1/4 W 745-0785-000
R82	RESISTOR	1 K 1/4 W 745-0749-000
R83	RESISTOR	10 K 1/4 W 745-0785-000
RT1	RESISTOR, THERMAL	1 K 1 W 714-1732-000
RT2	RESISTOR, THERMAL	10 K 1 W 714-0182-000
T1	TRANSFORMER, AUDIO INPUT	667-0187-030

D 2041 19 651

parts list

SYMBOL	DESCRIPTION	COLLINS PART NUMBER
T2	TRANSFORMER, AUDIO INPUT	667 0187-030
U1	INTEGRATED CIRCUIT	351-1175-010
U2	INTEGRATED CIRCUIT	351-1035-020
VR1	ZENER DIODE	353-6481-470
VR2	ZENER DIODE	353-6481-510
XK1	SOCKET, RELAY	220-0027-010
XU1	SOCKET, INTEGRATED CIRCUIT	220-0001-010
XU2	INSULATOR, DISC	352-9552-060

D 2041 19 851

Section 7

Diagrams

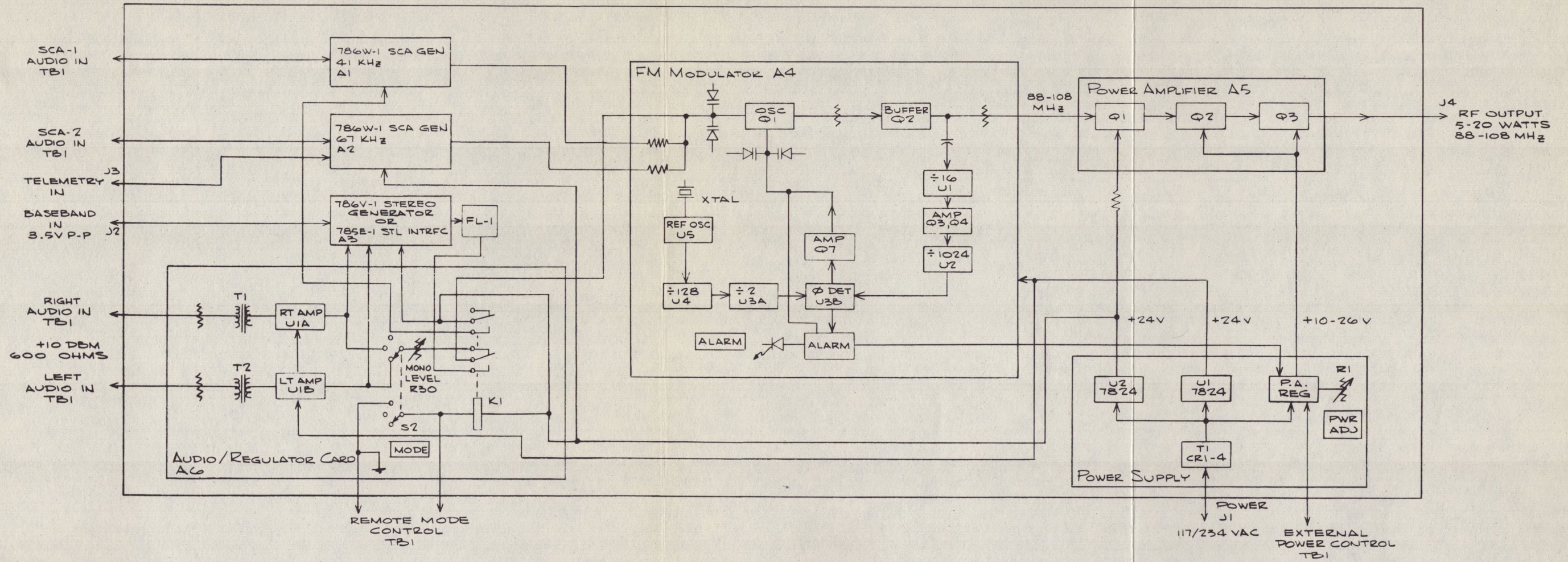

NOTE: METERING CIRCUITS NOT SHOWN

B528 099 Rp



If You Didn't Get This From My Site,
Then It Was Stolen From....
www.SteamPoweredRadio.com

Figure 7-1. 310Z-2 FM Exciter, Detail Block Diagram.

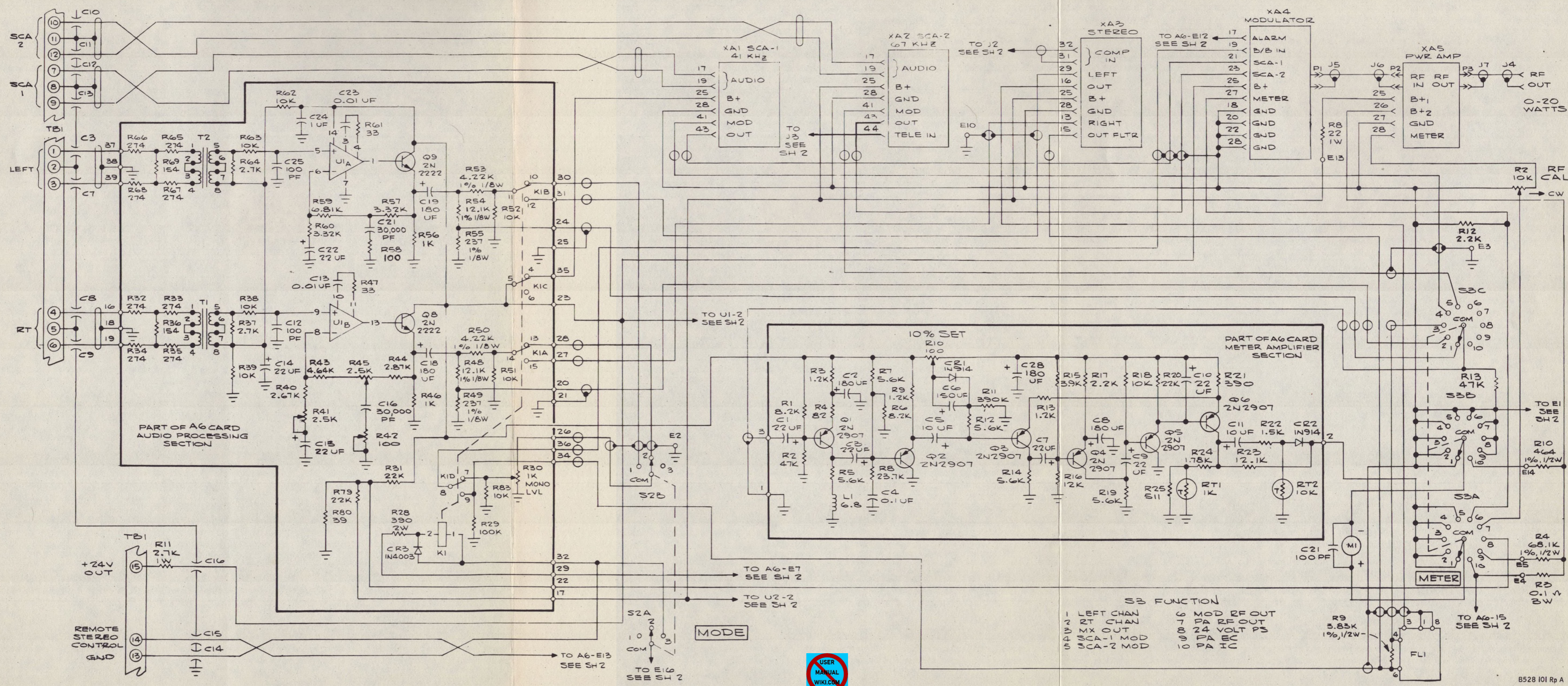

If You Didn't Get This From My Site,
Then It Was Stolen From....
www.SteamPoweredRadio.com

Figure 7-2. 310Z-2 FM Exciter Main Frame, Schematic Diagram (Sheet 1 of 2).

7824 = MAX. 40V IN

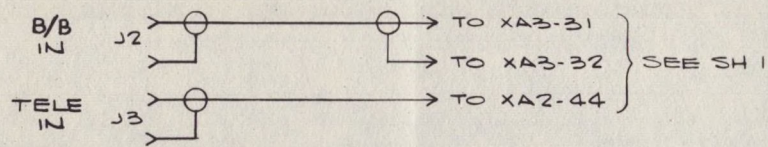

POWER CONNECTIONS		
VOLTAGE	LINE	JUMPER
117 VAC	1-5	1-3, 2-4
234 VAC	1-5	2-3

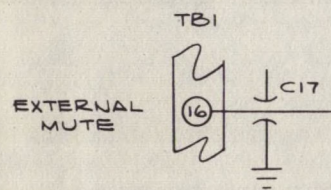
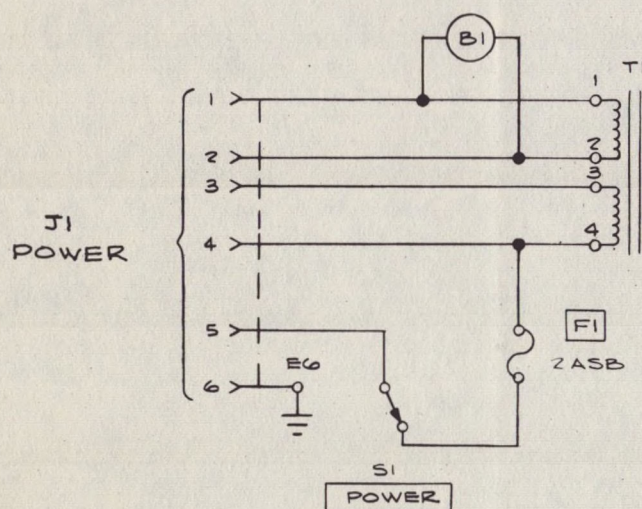

200V/12A

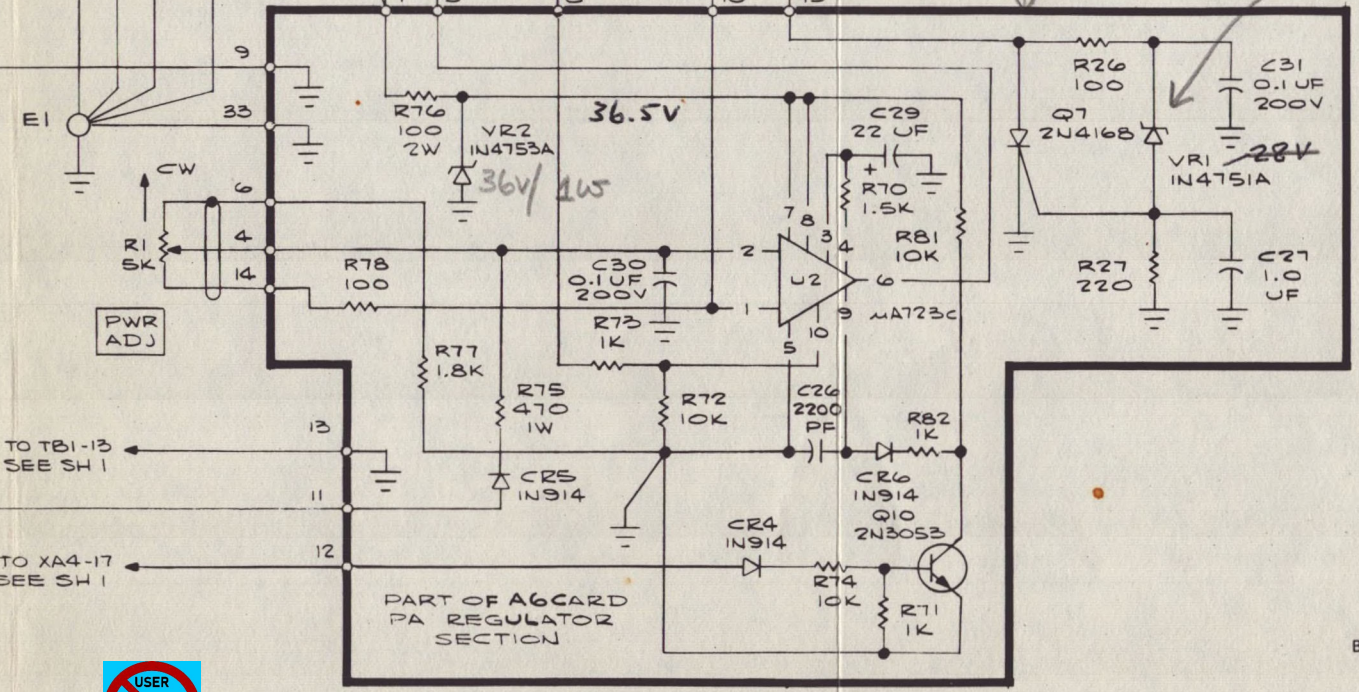
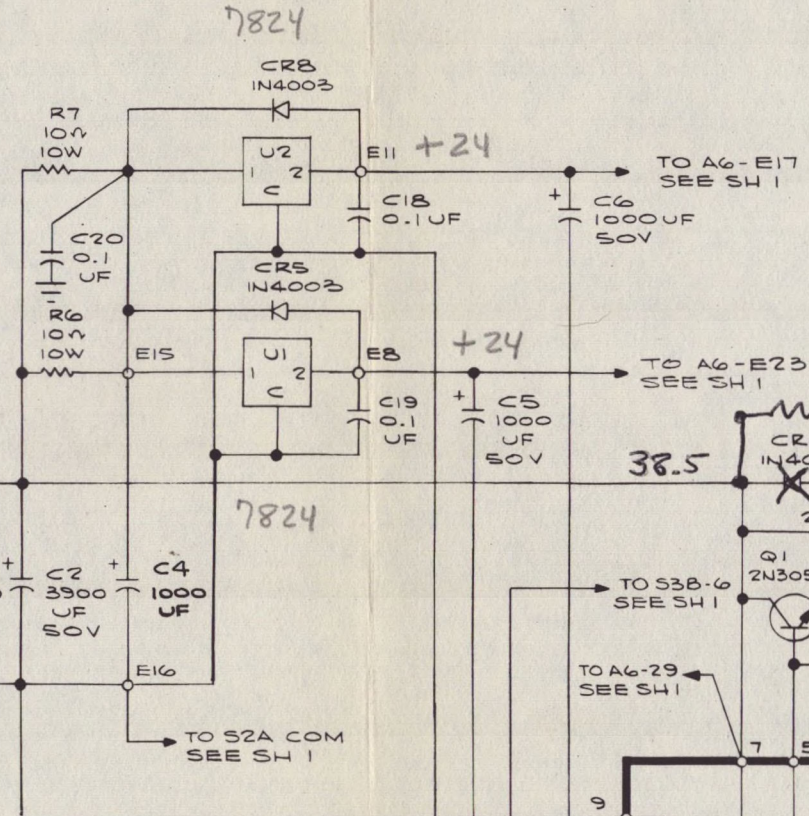

- NOTES:
- FUNCTIONS CONTAINED IN BLOCKS DENOTE FRONT PANEL MOUNT COMPONENTS (WITH EXCEPTION OF J1 POWER CONN)
 - UNLESS OTHERWISE SPECIFIED RESISTORS ARE 1/4 WATT 10% CARBON
 - CAPACITORS C3,7-17 ARE 1000 PF, 50V FEED-THRU TYPE

5A/50V/20MA IGT

30V/1W



If You Didn't Get This From My Site,
Then It Was Stolen From....
www.SteamPoweredRadio.com

Figure 7-2. 310Z-2 FM Exciter Main Frame, Schematic Diagram (Sheet 2 of 2).

B528 101 Rp B

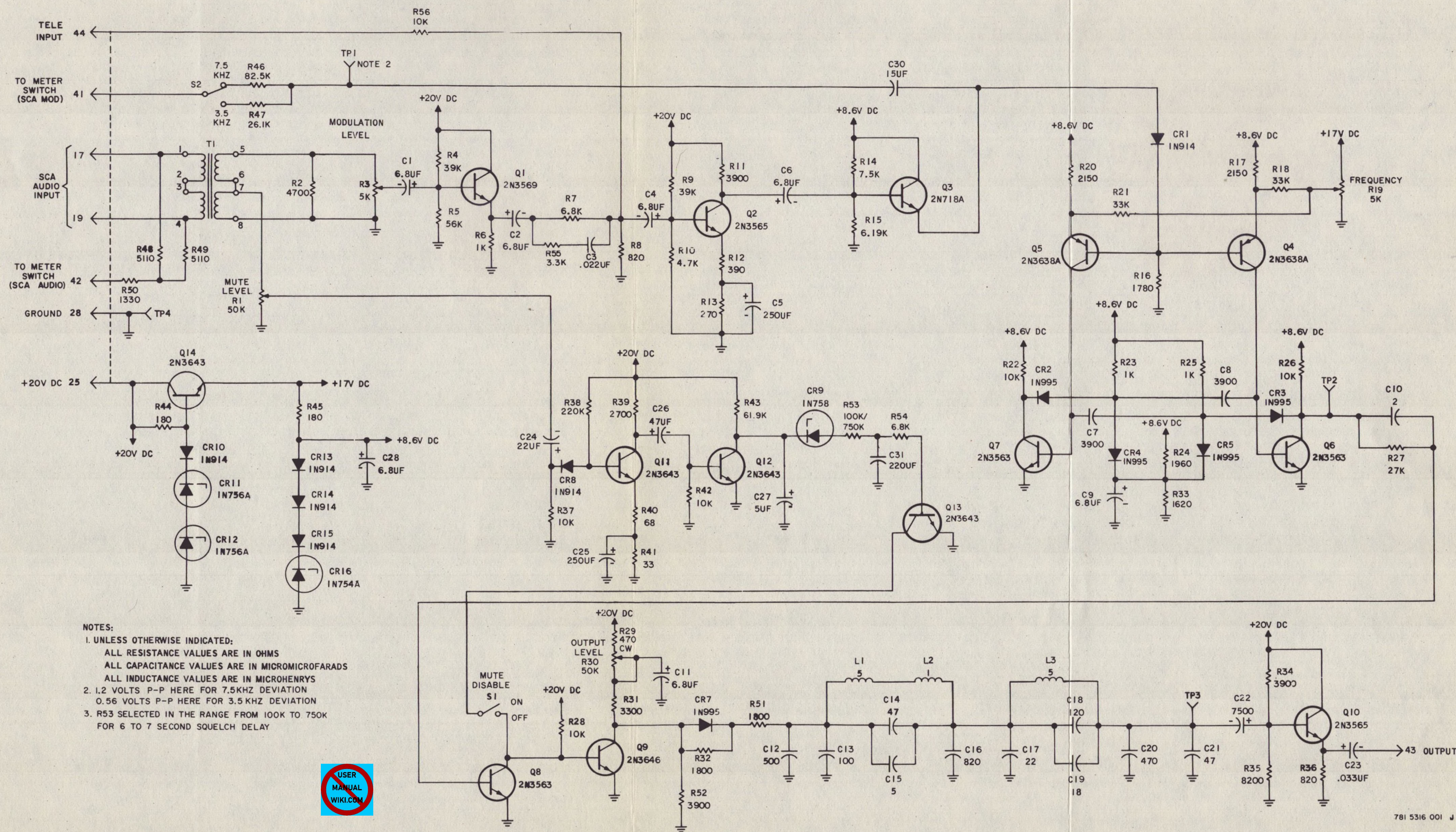

- NOTES:
- UNLESS OTHERWISE INDICATED:
 ALL RESISTANCE VALUES ARE IN OHMS
 ALL CAPACITANCE VALUES ARE IN MICROMICROFARADS
 ALL INDUCTANCE VALUES ARE IN MICROHENRYS
 - 1.2 VOLTS P-P HERE FOR 7.5KHZ DEVIATION
 0.56 VOLTS P-P HERE FOR 3.5 KHZ DEVIATION
 - R53 SELECTED IN THE RANGE FROM 100K TO 750K
 FOR 6 TO 7 SECOND SQUELCH DELAY



If You Didn't Get This From My Site,
 Then It Was Stolen From....
www.SteamPoweredRadio.com

Figure 7-3. 786W-1 SCA Generators A1/A2, Schematic Diagram.

781 5316 001 J

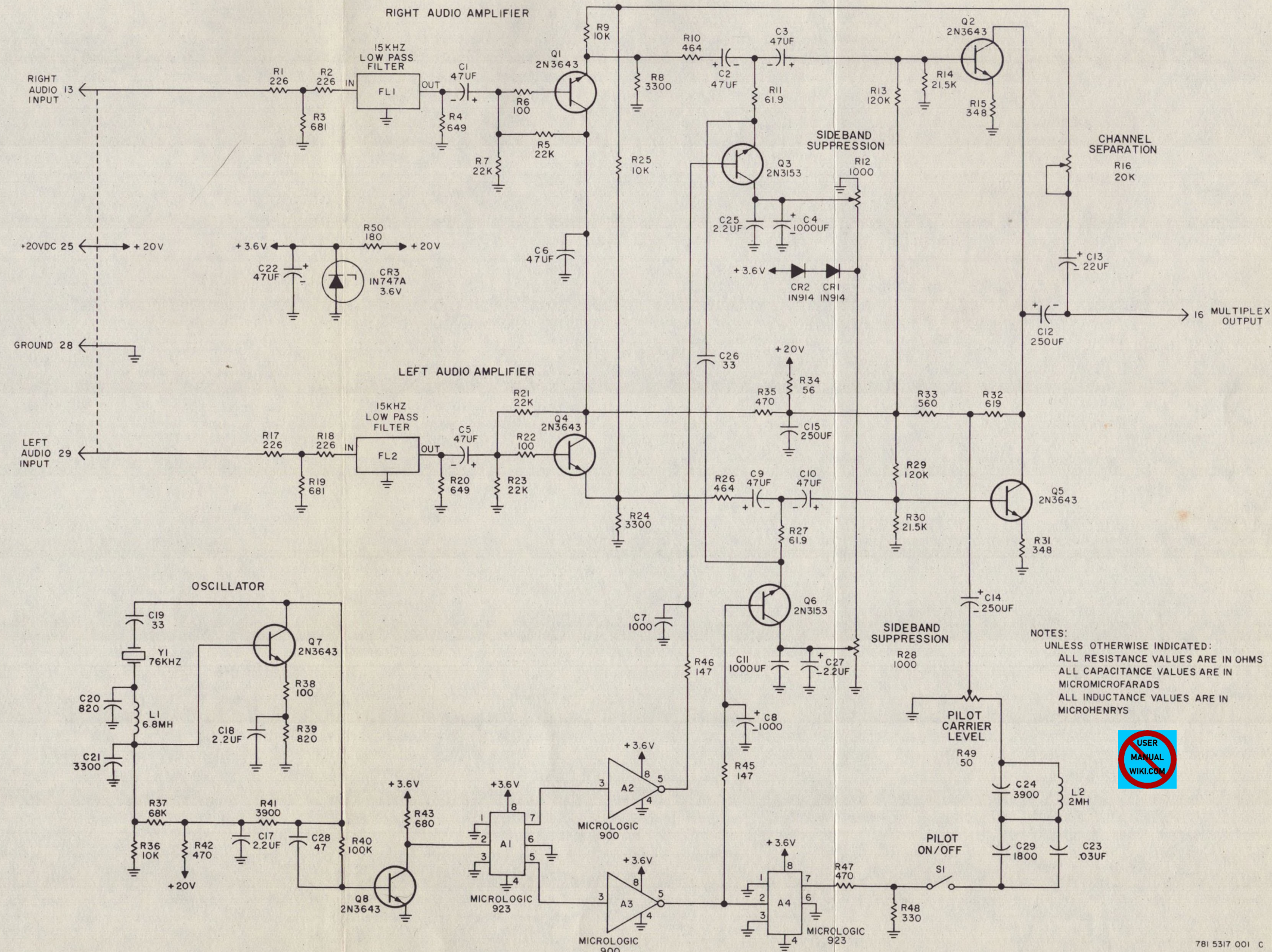

NOTES:
 UNLESS OTHERWISE INDICATED:
 ALL RESISTANCE VALUES ARE IN OHMS
 ALL CAPACITANCE VALUES ARE IN MICROMICROFARADS
 ALL INDUCTANCE VALUES ARE IN MICROHENRYS



If You Didn't Get This From My Site,
 Then It Was Stolen From....
www.SteamPoweredRadio.com

Figure 7-4. 786V-1 Stereo Generator A3, Schematic Diagram.

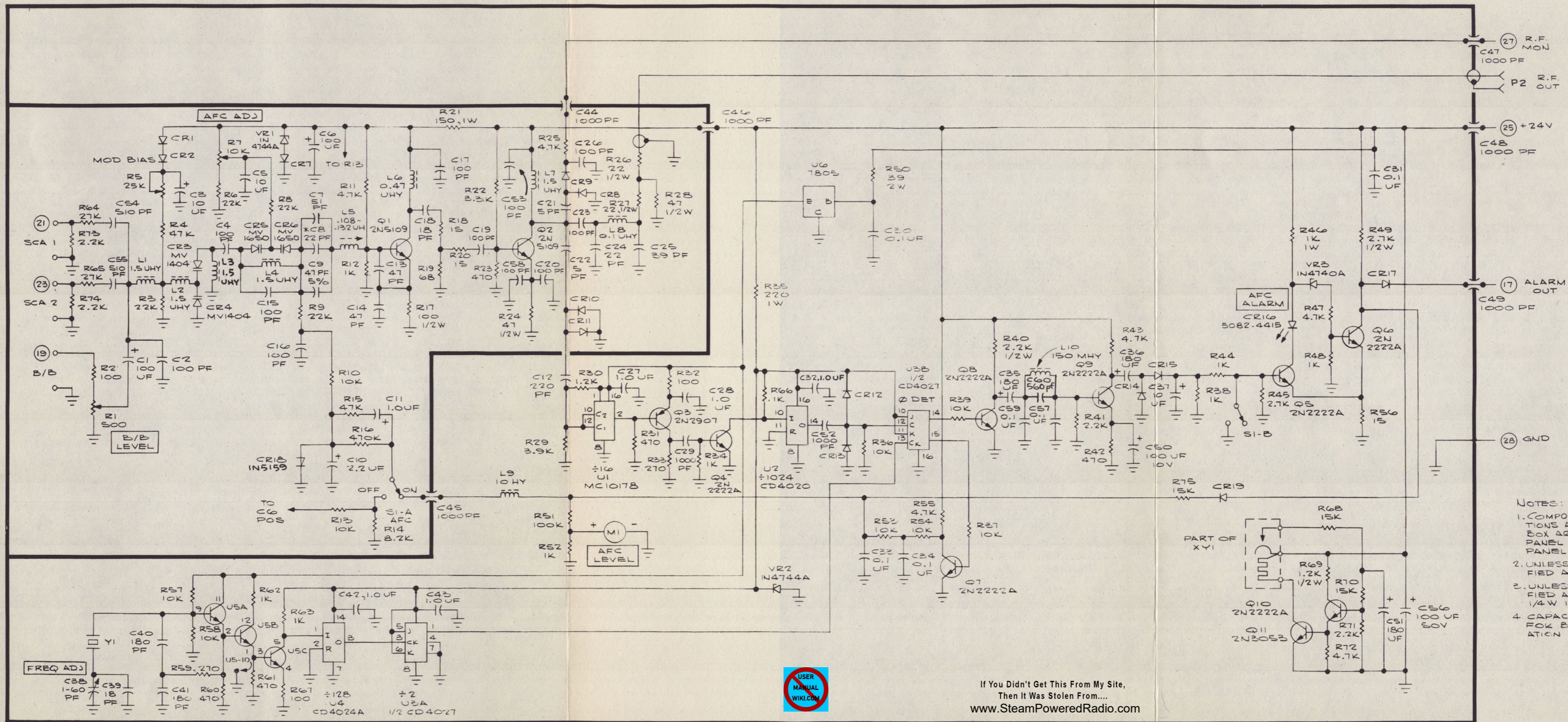

- NOTES:
1. COMPONENTS WHOSE FUNCTIONS ARE ENCLOSED IN A BOX ARE EITHER FRONT PANEL ADJUST OR FRONT PANEL MOUNT
 2. UNLESS OTHERWISE SPECIFIED ALL DIODES ARE 1N914
 3. UNLESS OTHERWISE SPECIFIED ALL RESISTORS ARE 1/4W 10%
 4. CAPACITOR C8 IS USED FOR BELOW 92 MHZ OPERATION ONLY



If You Didn't Get This From My Site,
Then It Was Stolen From....
www.SteamPoweredRadio.com

Figure 7-5. FM Modulator A4, Schematic Diagram.

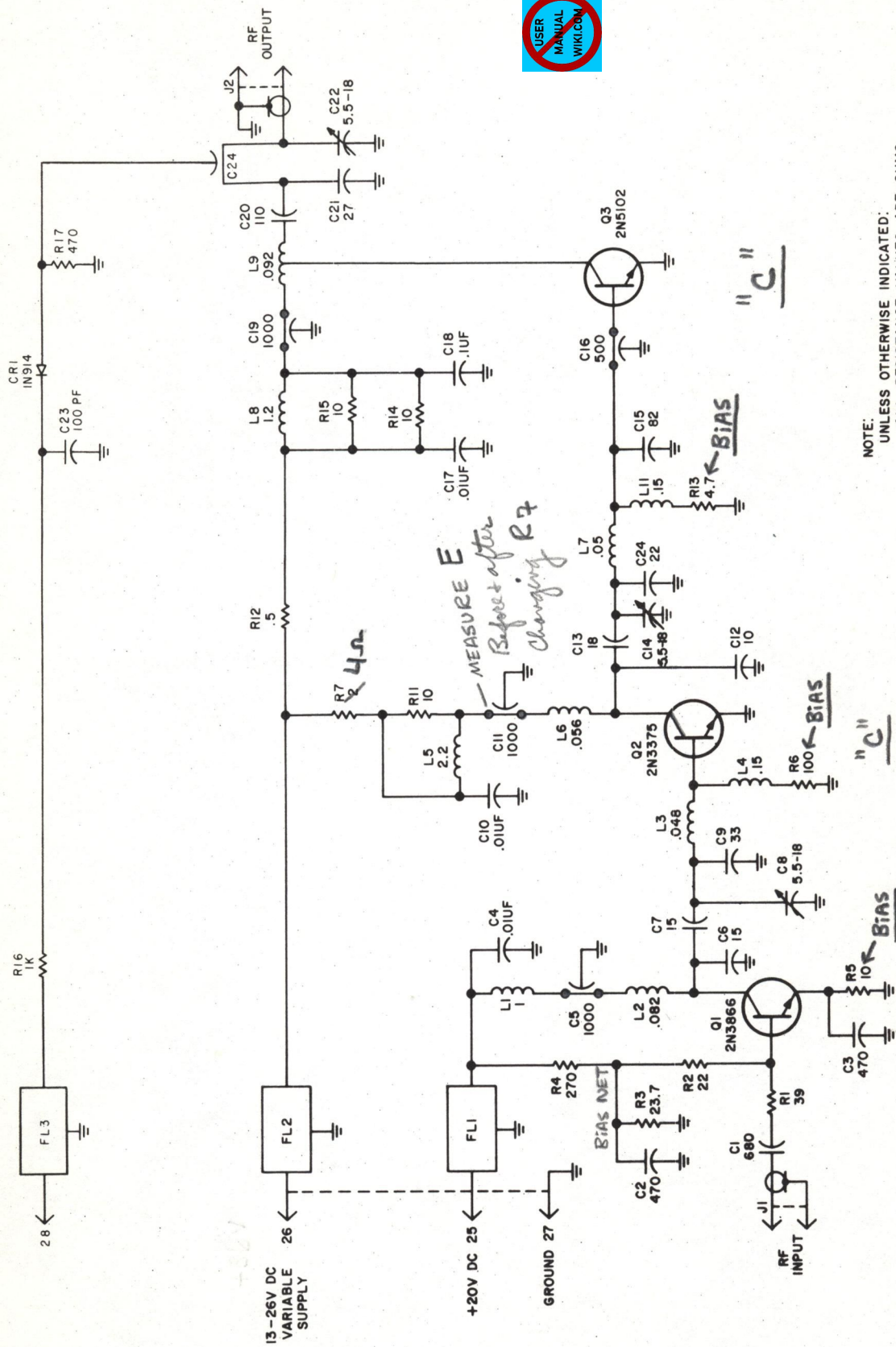

NOTE:
 UNLESS OTHERWISE INDICATED:
 ALL RESISTANCE VALUES ARE OHMS
 ALL CAPACITANCE VALUES ARE IN MICROMICROFARADS
 ALL INDUCTANCE VALUES ARE IN MICROHENRYS

781 5322 001 A

Figure 7-6. RF Amplifier A5, Schematic Diagram.

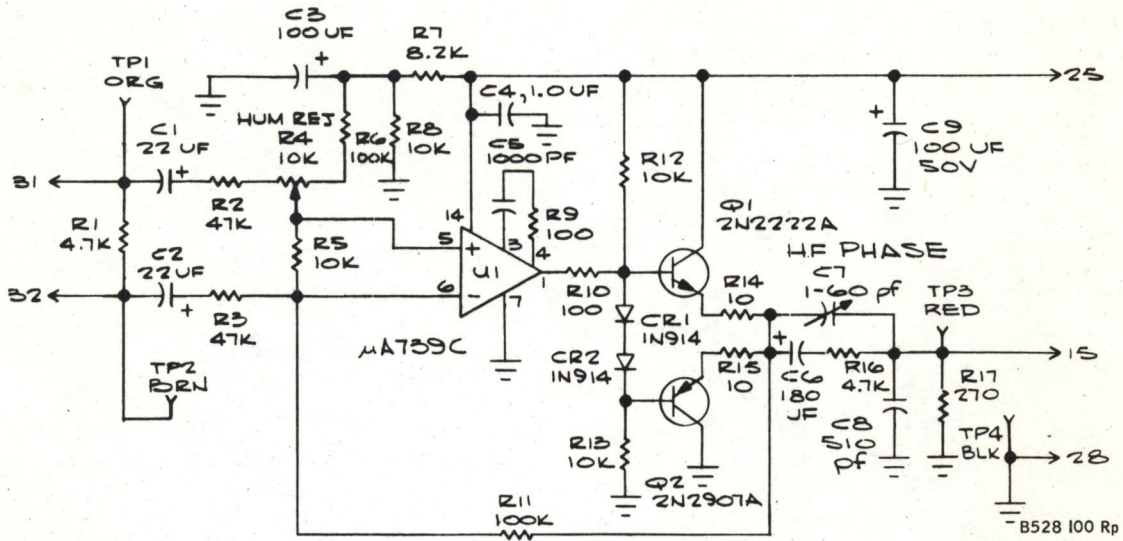

Figure 7-7. 785E-1 STL Interface Card A3, Schematic Diagram.

