

# GATES



HARRIS  
INTERTYPE  
CORPORATION

LEWIS J. DENES

SALES ENGINEER

ROUTE 2, BOX 584-A, BORING, OREGON 97009

PHONE 503/658-2684

GATES RADIO COMPANY

A SUBSIDIARY OF HARRIS-INTERTYPE CORPORATION  
QUINCY, ILLINOIS 62302

INSTRUCTION BOOK  
FOR  
THE EXECUTIVE  
GATES' 994 6158 001 STEREO TRANSISTOR CONSOLE



IB # 888 0745 001  
6/26/62

[www.SteamPoweredRadio.com](http://www.SteamPoweredRadio.com)

Gates Radio Company  
Quincy, Illinois

THE EXECUTIVE

994 6158 001 STEREO TRANSISTOR CONSOLE.

INDEX

	Page
SPECIFICATIONS .....	1-2
INTRODUCTION .....	1
INSTALLATION .....	2
Ambient Temperatures .....	3
Cable and Conduit Layout .....	3
Grounding Circuits .....	4
Balanced and Unbalanced Lines .....	5
Circuit Impedances .....	5
INSTALLATION - WIRING .....	6
Power Connections .....	6
Studio Intercom Wiring .....	6
Monitor Speakers .....	7
Microphone Input Connections .....	7
Turntable Inputs .....	9
Tape Inputs .....	10
Remote Inputs .....	10
Network Input.....	11
Nemo Input .....	11
Line Output Connections .....	11
Earphone Connections.....	11
OPERATION .....	11
Microphone Selector Switches .....	11
Turntable Switching .....	12
Tape Input Switching .....	12
Remote Input Switching .....	13
Network Input .....	13
Nemo Input .....	14
Monitor Input Selector and Level .....	14
Line Amp Input Selectors .....	14
Master Gain Controls .....	15
Cue-Intercom System .....	15
VU Meter Switch .....	16
Headphone Jacks .....	16
PRINCIPLES AND THEORY OF OPERATION .....	16
Transistor Amplifier Circuitry .....	17
Cue-Intercom System .....	17

Simultaneous Feed to Line Amp 2 & 3.....	18
Mixing System .....	18
VU Meter and Isolation Pads .....	18
Relay Deck .....	18
Speaker Matching Transformers .....	19
Regulated Power Supply & Power Transformer .....	19
MAINTENANCE .....	19
Voltage Measurements .....	19
Mechanical Components .....	20
MODIFICATIONS .....	20
Patch Panel Facilities .....	21
Muting Relays .....	21
Stereo Network Operation .....	22
WARRANTY	
PARTS LIST .....	1-5

DRAWINGS:

- 842 3492 001 - Functional Block Diagram
- 852 5854 001 - Console Schematic
- 826 8534 001 - Component Layout
- 813 7290 001 - Microphone Input Connections
- 813 7289 001 - Power Transformer and Warning  
Light Connections
- 813 7300 001 - Monitor Speaker Connections
- 813 7721 001 - Earphone Jack Connections
- 842 3485 001 - Schematic, M-6205 Regulated Power Supply

INSTRUCTION BOOKS:

- M-5700A Transistorized Program Amplifier
- M-6034 Transistorized Console Preamp
- M-6035 Transistorized Cue-Intercom Amplifier
- M-6108 Transistorized Monitor Amplifier
- Replacing Component Parts

6/28/62

The Executive  
994 6158 001

## SPECIFICATIONS

### THE EXECUTIVE

#### 994 6158 001 STEREO TRANSISTOR CONSOLE.

##### GAIN:

Remote/Network to Line Out: 56 DB  $\pm$  2 DB  
Remote/Network to Speaker: 58 DB minimum  
Microphone Input to Line Output: 104 DB  $\pm$  2 DB.  
Turntable Input to Line Output: 62 DB  $\pm$  2 DB.  
Microphone Input to Speaker Output: 106 DB minimum.  
Turntable Input to Speaker Output: 64 DB minimum.

##### FREQUENCY RESPONSE: (1 KC Reference)

+1.0 DB from 30 to 15,000 cps in all regular program circuits.  
+2 DB from 30 to 15,000 cps in all emergency program circuits.  
+1.5 DB from 30 to 15,000 cps in all monitoring speaker circuits.

##### HARMONIC DISTORTION:

0.5% maximum, 30 to 15,000 cps @ +8 DBM output on all program lines.  
0.5% maximum, 50 to 15,000 cps @ +18 DBM output on all program lines.  
1.0% maximum, 50 to 15,000 cps @ +39 DBM (8 watts) output on all monitoring speaker outputs.

##### I.M. DISTORTION:

0.5% maximum (40/7000 cps @ 4:1) @ +8 DBM equivalent sine wave output on all regular program circuits, 1.5% maximum @ +18 DBM out.  
1.0% maximum @ +39 DBM equivalent sine wave output on all monitoring speaker outputs.

##### NOISE:

-122 DBM relative input noise on microphone channels.  
-75 DBM relative input noise on turntable channels.

##### CROSSTALK:

Below noise level in all stereo channels.

##### CHANNELS:

10 Stereophonic.

INPUTS:

6 stereo mics, 4 stereo turntables, 4 stereo tapes, 4 mono remotes and 1 mono network (can be wired for stereo), and 1 high level auxiliary stereo input.

OUTPUTS:

Program left, program right, program compatible, 3 stereo speaker lines with muting (plus one optional), 1 stereo speaker line without muting 2 studio intercom speaker lines and 2 phone jacks.

TOTAL TRANSISTORS:

2N422	Qty.	13
2N1414	Qty.	53
2N214	Qty.	5
2N1183	Qty.	8
2N1225	Qty.	4
2N1539	Qty.	6
	Total	<u>76</u>

SIZE:

53½" long, 11-3/8" high, 17-3/8" deep.  
Net weight 107 lbs.

## INTRODUCTION

The Gates 994 6158 001 Stereo Control Console is a versatile and efficient ten channel audio control center especially designed to fill the need for such equipment created by the establishment of FM stereo broadcasting.

This console provides for the mixing cueing, and monitoring of a variety of program sources. These sources include microphones, turntables, tape recorders, remote pickups, and networks. These signals are fed to the two stereo channels in the transmitting system.

Due to the flexibility of the console, other combinations of output feeds are also possible. Provisions are included for the addition of a third output channel so that, simultaneously with the FM stereo program feed, a compatible signal (combination of left and right) may be fed to the AM transmitter. This third channel may also be used to broadcast a completely different monophonic signal to the AM transmitter. When stereo programs are not being broadcast, the two output channels of the console may be used to feed a monophonic signal to two transmitters simultaneously, or two completely different programs may be handled at once.

Microphone input switching is arranged so that a single microphone can feed both channels for isolated monophonic announcements on stereo broadcasting. Or, two microphones can be used for stereo announcements. Stereo monitoring of both the program output and the audition bus is provided, as well as an external stereo monitor amplifier input.

More details on the operation of the console may be found in the section of this book titled OPERATION.

The console is completely transistorized and self-contained except for the power transformer, which has been placed externally to minimize hum pickup in the console and the earphone jack panel.

Breaking and jumpering of all major circuits allows full use of normalling jack fields, with all connections brought out to terminal blocks for ease of installation and future circuit checking. Three speaker muting and warning light relays are supplied with provisions included for the addition of a fourth relay.

Compensation of signal levels by the use of fixed pads throughout the console minimizes the necessity of readjusting gain controls when switching from one circuit to another.

The cue-intercom system provides cueing of turntable and tape sources as well as intercom facilities between the control room and each of the studios as well as the remote lines. The cue-intercom system is interlocked with the speaker muting relays so that cueing and intercom signals cannot inadvertently get on the air.

This introduction has touched on some of the more important points of the console to give general information without excessive details. Those concerned with the daily operation should study the section labeled OPERATION. The installation crew should study their section before actually starting the work. Each section is broken down to cover different phases so that unnecessary confusion may be eliminated and the answer to any particular question may be easily found. The engineering staff is urged to become acquainted with all sections so that they can advise other groups in the best performance, as well as being able to keep the console in top operating condition.

### INSTALLATION

All the packing material, including any shipping frames and platforms, should be carefully removed prior to the installation of the M-6158 Stereo Control Console. The removable items include:

6	994 6034 001	Transistor Preamplifiers.
2	994 6034 001	Transistor Booster Amplifiers (same as the Preamplifiers).
2	994 5700 001	Transistor Program Amplifiers.
1	994 6035 001	Transistor Cue-Intercom Amplifier.
1	992 1335 001	Phone Jack Plate.
1	472 0429 000	Power Transformer
1	646 0379 000	Group of Knob Decals.
1	888 0745 001	Instruction Manual.

If any of the items listed above are missing, search all of the packing material again to determine if they have been overlooked. If still missing, contact the Gates Radio Company for instructions.

SIZE: The M-6158 Console is 53-1/2" long, 11-3/8" high and 17-3/8" deep. The net weight is 107 pounds.

With the plug-in amplifiers removed, place the console on the control desk in the final operating position. Determine the routing of the interconnecting cables into the cabinet and the method of connecting the cables to the control desk. The conduit and/or duct layout should also be considered in the planning of the interconnecting cable runs. If the cables are to come up through the surface of the desk, mark the cable access holes (in the console base) on the desk top so they may be accurately drilled after removal of the cabinet.

In some cases, it is preferred to elevate the console cabinet sufficiently to permit the cables to lay between the desk top and the console base, making a right angle turn with the cables to enter the cabinet. The cables are then dressed off the rear of the desk and generally a protective cover is installed down the rear of the desk.

In either type of installation, the console should be fastened securely to the control desk after the wiring is complete. This is facilitated by the holes in the center of several of the large dimples in the cabinet base. The wiring adjacent to the mounting holes should be fully protected during the securing operation.

#### AMBIENT TEMPERATURES

The transistor amplifiers and the power supply used in the console have been designed for reliable operation at temperatures up to 55° C. or 131° F. No special ventilation is required. However, prolonged sine wave testing (especially in the monitor amplifiers) should be avoided to allow heat, built up in the power output transistors, to be dissipated. See the instruction books provided at the end of this manual for more information.

#### CABLE AND CONDUIT LAYOUT

Cable and conduit layout is of utmost importance in the studio installation. Good results, with a minimum of noise and cross-talk, require careful planning and construction. A system hastily installed, without thorough planning, invariably results in continuous trouble until rebuilt.

First, the matter of signal levels: Cables should generally be divided into three groups, low level cables may include levels from -60 DBM to -20 DBM. Medium level cables may include levels from -20 DBM to +14 DBM. The high level cable may include levels from +14 DBM to +40 DBM. AC power wiring should be run in separate cables.

Whenever possible, do not run any of the four cables listed in a conduit along with cables of different level classification. If two or more cables must be run in a common conduit, never exceed a difference of 40 db in level between the highest and the lowest level in either cable. Use high quality shielded twisted pair for all audio wiring, such as Gates catalog number 1261. For all microphone wiring and long medium level cable and conduit runs the use of rubber, plastic or cloth covered shielded pairs eliminates multiple ground loops and the resultant noise problems. Gates catalog number 8440 microphone cable is recommended.

In parallel cable runs of different levels, the most important aid is physical isolation. Up to six inch spacing is preferred. If there is not room for this isolation, do not lace all of the wires in the same cables. Keep the cables laced separately for the different level classifications even if two or more must lay together. This will give much better isolation than when formed into one cable. The deviations from the preferred methods must not be taken lightly. Use them only as a last resort, not just for convenience.

Terminal layout is arranged in the console to allow adequate separation of cables up to the point of connecting to the terminal blocks. Low level microphone cables connect on the left to TB1. Medium level cables connect in the center to TB3. High level cables connect to TB4 and (in the rear) to TB6. Intercom wiring connections are brought out to TB6 since these are auxiliary circuits which may vary in level from -50 DB to +28 DBM. The speaker output cables are high level and should not be run with low level cables.

Conduit generally affords enough shielding so that different levels in separate conduit presents no isolation problem even without spacing them apart. Microphone level conduit and speaker level conduit can probably run along together with no crosstalk. However, if practical, it is advisable to maintain physical separation and add to the safety of the installation. Power circuits, especially those with high current, should not be in close proximity with program carrying conduit; electro-magnetic shielding is poor in most conduit.

#### GROUNDING CIRCUITS

Grounding circuits, like cable layout and most systems work methods, are unpredictable to a certain extent. Therefore, no hard and fast rules apply 100% of the time. In this section it is attempted to cover the things to avoid and to present generally accepted practices that always give good results, or allow good results to be obtained with minor modification. Entirely different approaches have been used, some with good results, but unless you are an expert on the subject, most are risky.

The console grounding system is based on the one point ground. Different circuit grounds are insulated from the chassis and other grounds except at one point, where they all join together and go to earth ground. This system prevents multiple ground loops with the resulting hum pickup from circulating currents and RF pickup and regeneration.

External circuits connected in the console should not destroy this system. Microphone circuits are not grounded in the console. The shields should not be grounded externally except after noise checks. They may then be grounded if better results are obtained. Turntable and tape inputs are unbalanced and the common side is grounded. If the inputs are unbalanced, the common side should connect to the back row of the terminal blocks (1B, 2B, 3B, etc.). If the input circuit is grounded external to the console, the ground should be lifted if possible to prevent ground loops. If the ground cannot be removed, or if the circuit impedance will not match the 600 ohm input, a matching transformer should be used. Order Gates A-21 line matching and isolation transformer.

Thus, a safe rule to follow is: Do not ground either side of external circuits. Generally, the shields of the cables should ground at the console only. They may be connected to the ground terminals in the console. There may be exceptions to this rule, especially on microphone input circuits, so the shield grounds should be wired in such a manner that they can be lifted in the console and grounded at the other end. Again, this is part of the test procedure to obtain lowest noise.

If patch panel facilities are used, special consideration of circuit grounding is necessary. Look in the section marked MODIFICATION FOR EXTRA FACILITIES for instructions.

#### BALANCED AND UNBALANCED LINES

If a circuit is ungrounded, it is considered balanced to ground. If one side is grounded it is unbalanced. If the circuit is center-tap grounded with a pad or coil it is balanced to ground. Refer to the third paragraph under GROUNDING CIRCUITS for determining proper classification. Twisted shielded pairs should be used for all circuits whether they are balanced or unbalanced. Cancellation of noise and crosstalk pickup is approximately the same for either when the one point ground system is used.

If it is necessary to connect a balanced line to an unbalanced line, or the opposite, an isolation transformer should be used between them. The transformer must have good balance, an electrostatic shield, and magnetic shielding sufficient to reduce the hum pickup at least 65 DB below the signal level. Impedance taps on primary and secondary are important to properly match both circuits. The Gates Radio Company's general catalog lists these transformers. Balanced lines require balanced pads and attenuators, unbalanced lines require unbalanced ones. Mixing them generally results in poor noise, frequency response or other poor operation.

#### CIRCUIT IMPEDANCES

The microphone inputs are factory connected for 150 ohms. These are balanced inputs. The impedance can be changed to 50 ohms balanced by changing the connections of the input transformer on the preamp board. See the preamp instruction book included at the back of this book for more information on this change.

The turntables and tape inputs are 600 ohms unbalanced. These impedances cannot be changed in the console and if other impedances are desired, a matching pad or an isolation transformer must be used. If a matching pad is used it should be unbalanced and its common side connected to the common or grounded side of the inputs.

The remote input lines and the auxiliary stereo input to channel 10 are 600 ohm balanced circuits. The impedance can be changed by changing taps on T1, T9, and T10, the matching transformer in these channels. As connected, to 1 and 3, the impedance is 600 ohms. Connect to 1 and 2 for 150/200 ohms and to 2 and 3 for 30/50 ohms. The net input to channel 9 is 600 ohms and no matching transformer is included in this channel. If other impedances are desired an external transformer must be used.

## INSTALLATION - WIRING

### POWER CONNECTIONS

A 117 VAC circuit should be connected to terminals 1 and 3 on the power transformer. Terminals 1 and 2 should be used if local AC line voltage is low (105-110 V.) and terminals 1 and 4 should be used where the AC voltage is high (120 to 125 V.).

The three 28 V. secondary windings of the power transformer, terminals 5 and 6, 7 and 8, 9 and 10 should be connected to terminal block 8, terminals 1 and 2, 3 and 4, 5 and 6.

117 VAC for the warning lights should be connected to terminals 1 and 2 of terminal block 7. Studio A warning lights connect to terminals 3 and 4 of terminal block 7. 117 VAC will appear at these terminals when channel one lever switch is placed in program or audition positions. Lights connected to these terminals should, therefore, be in the same studio as microphones connected to channel 1 inputs. Studio B warning lights should be connected to terminals 5 and 6. These lights will be on when channel 2 lever switch is in program or audition position and should be in the same studio as microphones connected to channel 2 inputs. Control room warning lights, activated by lever switch 3 should be connected to terminals 7 and 8 of terminal block 7. Terminals 9 and 10 are wired for use with a fourth relay. See the section on modifications for more information. Warning light circuits should not be grounded at any point and should not draw more than 2 amps of current. Drawing 813 7289 001 shows the above connections in detail.

### STUDIO INTERCOM WIRING

When connecting the studio intercom units, the wiring should be kept separated from program circuits. Connect the Studio A unit to terminal block 6, terminals 5A and 5B. The Studio B unit should connect to terminals 7A and 7B on terminal block 6. These circuits should not be grounded.

## MONITOR SPEAKERS

All speaker wiring is high level and must be run in separate conduit away from low level program circuits. Stereo monitoring is provided to all studios as well as external lobby speakers. 45/60 to 6/8 ohm speaker matching transformers should be used. Gates A-30601 speaker transformers are satisfactory. The relay deck has 47 ohm back loading resistors across the lines when the speakers are muted. Do not parallel speakers across the monitor outputs without using the matching transformers just mentioned since serious damage to the monitor amplifiers will result if they are operated with a load of less than 4 ohms.

Speakers connect as follows to terminal block 6 -

<u>Speaker</u>	<u>Terminal</u>
Studio A - Left	8A - 8B
Studio A - Right	9A - 9B
Studio B - Left	10A - 10B
Studio B - Right	11A - 11B
Control Room - Left	12A - 12B
Control Room - Right	13A - 13B
Lobby - Left	18A - 18B
Lobby - Right	20A - 20B

The "hot" side of each speaker should connect to the A terminal on TB6 to insure proper phasing of speakers for best stereo operation.

Studio A speakers will mute when channel 1 lever switch is in program or audition position. Studio B speakers mute when channel 2 lever switch is operated and control room speakers are muted when channel 3 lever switch is operated. SPEAKER CIRCUITS MUST NOT BE GROUNDED.

External monitor inputs, if used, should connect to TB5, 2A-2B for the left channel and TB5, 1A-1B for the right channel.

## MICROPHONE INPUT CONNECTIONS

Each microphone channel has provisions for two stereo microphone combinations, or a total of four microphones per channel. Switching between combinations, or from stereo to monaural, is done on the front panel.

Channel 1: With S9 in "mic 1" position and S12 in "stereo" position, the console is set up for stereo broadcasting from microphones connected to the first two inputs on terminal block 1. With S12 in "mono" position, the signal from microphone input 1 is fed through both preamps so that both left

and right channels will carry the same signal. Moving S9 to "mic 2" position, switches microphones connected to terminals 3 and 4 into the channel 1 preamps. The function of S12, the mono-stereo switch, remains the same with microphone 3 feeding both left and right channels (when S12 is placed in the "mono" position). Reference to the functional block diagram, drawing 842 3492 001, will help clarify these functions. Channel 1 microphones should be located in the same studio as the speakers that are connected to mute when the channel 1 lever switch is operated.

Channel 1 microphone connections are made to terminal block 1 as follows -

<u>Microphone</u>	<u>Terminal</u>
1 - Left	1A - 1B
1 - Right	2A - 2B
2 - Left	3A - 3B
2 - Right	4A - 4B

The microphone inputs are balanced 150 ohm and the external circuit should not be grounded.

(See Instruction Book for the preamps for information on changing the impedance to 30/50 ohms.) (See section on GROUNDING CIRCUITS for installation techniques.)

It is important in stereo broadcasting that the left and right program sources be in the correct phase with each other to maintain proper sound perspective. This fact must be taken into account when connecting inputs to the stereo console. Color coding of microphone cables or connector pin numbering should be noted and the same lead connected from each microphone to the corresponding terminal on TBl in each channel.

Microphone arrangements for channel 2 are the same as for channel 1. Switching functions of S10 and S13 are the same as S9 and S12 respectively, as explained above. The functional diagram drawing 842 3492 001, shows these functions. Channel 2 microphones should be in the same studio as the speakers connected to mute when the channel 2 lever key is operated.

Microphone connections to channel 2 are as follows -

<u>Microphone</u>	<u>Terminal Block 1</u>
3 - Left	5A - 5B
3 - Right	6A - 6B
4 - Left	7A - 7B
4 - Right	8A - 8B

Again, proper phasing must be obtained between microphones for best operation.

Switches S11 and S14 perform the same functions as S9 and S12 respectively, as explained under channel 1. Channel 3 microphones should be in the same studio as the speakers connected to mute when the channel 3 lever switch is operated. Again, phasing of inputs is important and microphone polarity should be closely observed.

Connections should be made as follows -

<u>Microphone</u>	<u>Terminal Block 1</u>
5 - Left	9A - 9B
5 - Right	10A - 10B
6 - Left	11A - 11B
6 - Right	12A - 12B

Drawing 813 7290 001 shows the above microphone connections.

#### TURNTABLE INPUTS

Provision is made for four stereo turntable inputs, each of which can be switched to mixers 4 or 5. Turntable inputs are medium level (-20 DBM) 600 ohm unbalanced. If the output of turntable preamp is unbalanced, the common side should be connected to the common side of the input terminals (Row B) on terminal block 3. As with microphone inputs, polarity of the turntable inputs must be observed to insure that right and left channel signals are in proper phase relationship. This requires checking of all the wiring from the stereo pickup, through the preamp to the console for proper connections. Inputs to the turntable channels should not be grounded externally. Isolation transformers may be used if necessary to isolate external grounds or to connect inputs that should not be grounded to the unbalanced turntable inputs.

Turntable inputs connect to terminal block 3 as follows -

<u>Turntable</u>	<u>Terminals</u>
1 - Left Channel	1A - 1B
1 - Right Channel	2A - 2B
2 - Left Channel	3A - 3B
2 - Right Channel	4A - 4B
3 - Left Channel	5A - 5B
3 - Right Channel	6A - 6B
4 - Left Channel	7A - 7B
4 - Right Channel	8A - 8B

See the section on OPERATION for details on switching functions.

## TAPE INPUTS

Four stereo tape inputs are provided, switchable between channels 6 and 7. These are "medium-level" 600 ohm balanced inputs.

Connections are made to terminal block 3 as follows -

<u>Tape</u>		<u>Terminal</u>
1	- Left	9A - 9B
1	- Right	10A - 10B
2	- Left	11A - 11B
2	- Right	12A - 12B
3	- Left	13A - 13B
3	- Right	14A - 14B
4	- Left	15A - 15B
4	- Right	16A - 16B

As with other stereo inputs, tape connections must be made with proper polarity to insure proper phasing of stereo signals.

Although the console is intended to handle 4 turntables and 4 tapes, more than this number of turntables may be used by connecting to tape inputs and switching them into mixers 6 and 7. Of course, one or more of the tape inputs must be sacrificed. In the same manner, more than 4 tape inputs can be obtained by using turntable inputs and bringing the additional tapes into mixers 4 and 5. In this case, one or more turntable inputs will be sacrificed. Of course, not all the tape or turntable inputs need be used.

## REMOTE INPUTS

Provision is made for the connection of 4 remote lines to mixer 8. These are "medium-level" 600 ohm balanced monophonic inputs. Connections for these inputs are located on terminal block 3 as follows -

<u>Remote Line</u>	<u>Terminals</u>
1	17A - 17B
2	18A - 18B
3	19A - 19B
4	20A - 20B

It is suggested that, rather than connect the remote lines directly to the console, they be brought out to jacks in the station patch panel to allow a greater versatility in programming. External circuits should not be grounded. The input level of these lines should be about -20 DBM. This allows the use of isolation pads or equalizers and still have sufficient gain for proper operation.

### NETWORK INPUT

A 600 ohm monophonic network input is provided with mixing accomplished through mixer 9. This channel can be converted to stereo if desired (see the section on MODIFICATIONS for details). As wired, the network will feed both left and right program channels. The network line should be connected to TB5, terminals 17A and 17B.

### NEMO INPUT

Channel 10 is a high level stereo channel provided for auxiliary use. Input connection should be made to TB5, 19A and 19B for the left channel and TB5, 20A and 20B for the right channel.

### LINE OUTPUT CONNECTIONS

The level of these lines will be +8 DBM and they should be routed carefully to prevent crosstalk back into low level input circuits. Connect output line 1 to TB4 terminals 13A-13B. Output line 3 connects to TB4 terminals 15A - 15B. Line 2, if used, connects to TB4 terminals 14A - 14B. These are 600 ohm balanced outputs. Observe correct phase relationship between output lines to insure proper sound perspective between left and right channels.

### EARPHONE CONNECTIONS

The earphone jacks for both the cue-intercom system and the line monitoring circuits are mounted externally on a jack panel. The panel should be mounted in a convenient location in the control room and shielded twisted pair should be used to connect to the console. Drawing 813 7721 001 shows the complete wiring details necessary for proper installation.

### OPERATION

The arrangement of panel controls gives maximum versatility to console operation while keeping actual operating as simple as possible. Control functions are explained in the following sections. In all cases, reference to the block diagram of the console, drawing 842 3492 001, will help clarify these functions.

### MICROPHONE SELECTOR SWITCHES

On the upper left side of the panel, above channel mixers 1, 2 and 3, are three pairs of switches. These switches perform identical functions for each channel. The microphone selector switch is used to switch between two sets of stereo microphones in each studio. With the mono-stereo switch in the

stereo position, the left and right microphones will be switched to the left and right program busses when the proper mixer key is placed to the right. These same microphones will be switched to left and right audition busses when the mixer key is placed to the left. If the mono-stereo switch is placed in the mono position, the left microphone will feed both left and right program or audition busses when the mixer key is placed in the program or audition position. This allows announcements to be made on both channels while broadcasting stereo from other microphone combinations. For stereo broadcasting, the line output switch must be in "stereo position", as explained under LINE INPUT SWITCHING.

#### TURNTABLE SWITCHING

The four turntable switches, above mixers 4 and 5, select the desired input to each mixer. When the channel switches, above mixer 4, are in the "OFF" position, turntable inputs are normalled through to the mixer 5 switches. When any of the switches in channel 4 are switched "ON", the turntable input will appear at the output of mixer 4. Moving the channel 4 mixer key to the right will bring up the turntable input on the left and right program busses, while moving the mixer key to the left will switch the signal to the left and right audition busses. Moving the desired turntable input switch to the "ON" position, above mixer 5, will switch the desired turntable input into this mixer. Switching is arranged so that a turntable cannot be switched into mixer 5, if it is already switched into mixer 4. This prevents loading the turntable output by paralleling it into two console inputs. Cueing facilities are provided for by turning either turntable mixer fader fully counterclockwise. This connects the turntable inputs to the cue-intercom amp. Cueing can be accomplished by using the panel mounted speaker or headphones (plugged into the cue phone jack). The operation of the cue-intercom system is covered in a later section. No special provision is necessary for monophonic operation, since mono records played on a stereo turntable will result in identical signals in both left and right channels.

#### TAPE INPUT SWITCHING

Mixers 6 and 7, located to the right of the VU meters are identical in operation to the turntable inputs discussed above. Four stereo inputs can be switched to either mixers 6 or 7. Outputs of mixers 6 and 7 can be switched to "program" or "audition" busses. Cueing facilities are provided by turning mixer 6 or 7 fully counterclockwise, thus, connecting the mixer to the cue-intercom system.

6/26/62

-12-

The Executive  
994 6158 001

## REMOTE INPUT SWITCHING

Four lever switches, located above mixer 8, control four remote inputs. The remote switches provide talkback and cueing facilities to the remote operator. In the center position, they receive program cue signal from the monitoring amplifier. The level is adjusted to approximately +8 VU. This signal is fed back to the remote operator to allow him to start his program at the proper time. The lower position is the "mix" position and connects the remote program into the program or audition bus through mixer 8. The upper position of the switches have a terminating load for the remote lines and allow over-ride and talkback functions. See the section CUE-INTERCOM SYSTEM for explanation of these functions. The remote lines are not tied together when any or all of the remote keys are in the talkback position. There is sufficient isolation between them even with the over-ride tie-in on all lines.

A typical sequence of operation for a remote line will be: Before air time, the studio operator would place the appropriate remote line switch in the "TB" position, and the cue-intercom input selector switch to the "remote" position. When the remote operator arrives at the broadcast site, he would call in on the remote line. The studio operator would hear his call and be able to talk back via the cue-intercom system. After preliminary instructions, the remote input switch would be placed in the "cue" position. When the remote operator receives his cue the remote input switch is moved to the "mix" position and the remote signal is brought up on mixer 8. An alternate method of operation, before contact is established with remote operator, is to place the appropriate remote input switch in the "mix" position and the channel 8 mixer in the "cue" position. This allows the remote operator to call in and be heard regardless of the position of the cue-intercom input selector. After the call is heard, the remote switch is placed in the "TB" position and the cue-intercom input selector to the "remote" position and the above procedure is followed.

## NETWORK INPUT

The network input is connected directly to mixer 9 and is put in use by placing the mixer key to the program or audition position and turning up the mixer gain control. Preview monitoring of the network is provided by turning the mixer control fully counterclockwise into the "cue" position. Network can then be monitored with the "cue input" switch in any position. If it is desired to monitor the network with the mixer turned up ready for use, the "cue input" switch should be turned to the "net" position allowing the network to be heard in the cue-intercom system.

## NEMO INPUT

Channel 10 is a stereo channel with the input connected directly into the mixer. Cueing is available by turning the mixer fully counterclockwise.

## MONITOR INPUT SELECTOR AND LEVEL

The monitor input selector is located on the lower center of the panel. Input switching allows stereo monitoring of program, audition or an external signal source. The gain of both the "left" and "right" monitor amplifiers is controlled by the dual gain control located to the left of the monitor input selector.

## LINE AMP INPUT SELECTORS

The inputs to line amplifiers 2 and 3 are selected by the two switches in the upper right corner of the panel. Only the inputs to the above amplifiers are switch selected. Line amp 1 is fed from the "left" program bus at all times.

For stereo broadcasting, line amp 3 input is switched to the "stereo" position. This switches the "right" program bus into line amp 3 and "left" and "right" stereo output will appear at the outputs of line amps 1 and 3 respectively. If it is desired to feed the same program to lines 1 and 3 simultaneously, the line amp 3 input switch should be placed in the upper or "simul." position. In this position, the signal on the left program bus will appear at both line 1 and 3 outputs. Placing the line amp 3 input switch in the center or "aud L" position switches line amp 3 input to the "left" audition bus. This enables the console to be operated as a dual channel console with line 1 being fed from the "left" program bus and line 3 being fed from the "left" audition bus. Stereo programs cannot be broadcast when the console is operated in this manner.

Provision is included for the addition of a third line amplifier to feed the line 2 output. With this unit in place, the versatility of the console is greatly increased.

The line amplifier 2 input switch selects the desired input. In the "L + R" position, a compatible (left plus right) signal is available at the output of line 2. This allows broadcasting a compatible monophonic signal on line 2 while a stereo program is carried on lines 1 and 3.

With the line amp 2 input switch in the "aud L" position the line amp is switched to the "left" audition bus. This allows a completely different monaural signal to be carried in the middle channel, while stereo is being broadcast on channels 1 and 3. When the line 2 amp input switch is placed in the "simul." position, the signal on the "left" program bus will appear simultaneously at both line 1 and 2 outputs.

It is evident that several possible operational setups are possible. Stereo can be broadcast on line 1 and 3 with a compatible (L + R) signal on line 2, or a completely independent program can be handled on line 2 through the "aud." bus. All three lines can handle the same program material, or the console can be used as a dual channel system, handling two separate programs into two or three lines.

#### MASTER GAIN CONTROLS

The gain controls for line amps 1 (left) and 3 (right) are located on the upper right side of the panel.

The gain control for the optional line amp is located on the amplifier itself, and is accessible at the right end of the amplifier when the console cover is raised. Signal levels in the console are adjusted with the input channel mixers so that control should not need adjustment after being initially set to match the output levels of lines 1 and 3.

#### CUE-INTERCOM SYSTEM

Controls for the cue-intercom amplifier are located below the VU meter.

The top control is the gain control, and controls the level for both the "talk" and "listen" functions. Below the level control is the cue-intercom input selector switch, which has 6 positions. In the "net" position, the network line can be monitored. Talkback is not possible in the network position. The remote 1, 2, 3 and 4 positions tie the cue-intercom amp to the 1, 2, 3, or 4 remote lines. For talkback facilities, the intercom selector is switched to the desired remote line and the appropriate remote input switch is placed in the "TB" position. The incoming remote signal line will then be heard in the panel mounted speaker. When the control room operator desires to talk out on the remote line, he simply pushes the red "talk" button in the center of the panel and speaks into the panel speaker. "ST1" and "ST2" positions allow listening and talkback into studios 1 and 2 if intercom units have been installed in them.

Levels are adjusted so that normal listening volume will provide sufficient gain for talkback purposes. The system is quite sensitive and does not require shouting or placing your mouth near the speaker.

Turntable and tape cueing circuits are connected directly to the input of the cue-intercom amp and may be used regardless of the position of the cue-intercom input selector.

The intercom speaker on the console is set up to mute when the channel 3 lever key is operated. This muting does not disable

the "cue phone" jack, so it is still possible to cue a record by monitoring the cue circuit with headphones. This jack is labeled "cue". The intercom speaker is interlocked with the headphone jack so that this speaker is muted whenever a phone plug is inserted in the "cue" jack.

The studio intercom speakers are muted with the regular speaker muting relays so that it is impossible to talkback to a studio when there is a live microphone in it. These relays operate when the microphone channel is switched to either the program bus or the audition bus. This interlocking feature makes it impossible to disturb the program and the console operator may use the intercom system without concern.

#### VU METER SWITCH

VU meter 1 is not switched but is connected permanently across the output of line 1. VU meter 2 is switched by the control directly beneath it. It may be used to monitor the level of output lines 1, 2, or 3, as well as the incoming network line. For monitoring, the network should be connected to TB4 terminals 16A - 16B, this should be a balanced input. A utility position is also furnished to allow the panel mounted meter to monitor an external circuit. Connect desired external circuit to TB4 - 17-17B. The meters are set to read 0 VU with an input level of +14 DBM. With the 6 DB isolated pads in the output of each line this setting gives the standard +8 DBM level in the outgoing lines. This level can be changed by changing the pads on the rear of each meter. These pads are marked AT21 and AT23 on the schematic, drawing 852 5854 001.

#### HEADPHONE JACKS

The headphone jack labeled "line" is provided for headphone monitoring of all output program circuits. Phones can be switched to the desired circuit by the switch labeled "phones". The upper or "stereo" position provides monitoring of the stereo program on lines 1 and 3. Stereo headphones with balanced separated inputs must be used. Switch positions marked "AL1", "AL2", "AL3", provide monophonic monitoring of the outputs of line amplifiers 1, 2, and 3 respectively. The "network" position allows monitoring the incoming network line. The network should be tied to TB4, terminals 16A-16B. The jack labeled "cue" allows monitoring the cue-intercom system with headphones if desired. See the section on the CUE-INTERCOM SYSTEM for more information.

#### PRINCIPLES AND THEORY OF OPERATION

This section is included to give the engineer a better understanding of some of the more unusual features of the console.

The very obvious methods of operation will not be covered, since they are common knowledge, or have been covered in previous sections of this instruction book.

### TRANSISTOR AMPLIFIER CIRCUITRY

Complete details on the various amplifiers used in the console will be found in the individual instruction books included in the back of this manual. However, a word here about the circuitry will aid in explaining overall console setup. The pre-amps, monitor booster amps, cue-intercom amp and the monitor amps, have transformerless output circuits. Grounding of external wiring is critical for best noise figures and to avoid crosstalk, especially in the high gain cue-intercom amp. If modifications are made on the console, care should be exercised to insure that unwanted grounds do not enter the picture. Under no circumstances should the monitor speaker wiring be grounded externally.

### CUE-INTERCOM SYSTEM

Reference to the schematic, drawing 837 9345 001, of the cue-intercom amplifier; and to drawing 852 5854 001, the overall console schematic for the wiring of this system; will aid in understanding the operation of the cue-intercom system.

An interstage volume control, remotely mounted on the front panel, helps reduce noise at normal operating levels.

The incoming remote lines normally operate with a signal level of up to +8 VU. This level is padded down, to a level sufficiently low to prevent overloading the cue amplifier, when listening to the remote lines. These pads consist of the 620 ohm resistor across the input of each remote line and the 5100 ohm resistors in series with each side of the line. These pads are built up on S38, the cue-intercom input selector switch, located on the front panel. These pads also give isolation between lines when more than one line is switched into the cue amp.

The maximum gain of this amplifier is approximately 90 db. Since the input and output of the amplifier comes in close proximity at the talk-listen relay (K5), wire dress is very important here. The grounding of the cue-intercom system is also very critical. Do not allow any part of the external speaker or other system to be grounded. They are grounded in the console. Shielding of all external speaker lines is necessary to prevent hum and possible regeneration.

The frequency response of the amplifier is rolled off severely on both ends of the spectrum to provide the best compromise of cueing and intercom functions. Do not attempt to alter it without taking all of the circuit requirements into consideration.

## SIMULTANEOUS FEED TO LINE AMP 2 & 3.

The line amplifier input switches allow switching the output of line amp 1 into line amp 2 and 3. Pads AT12, AT13, and AT14 adjust the signal level to a level comparable to those appearing at the other positions of the line input switches. The absolute output level of line amp 2 will depend upon the relative gain control settings of both line amps 1 and 2. For example, pads AT12 and AT13 have a total loss of 65 DB. If both line amps are set to have a gain of 65 DB, a -55 DBM signal applied to the input of AL1 will appear at the output at a +10 DBM level. After passing through the pads it will appear at the input of AL2 at a -55 DB level. AL2 has the same gain as AL1 so it will appear at output of AL2 at +10 DBM also. However, if the amplifiers are set for different amounts of gain, the signal will not be the same at both outputs. A signal amplified 70 DB for example, will be padded down only 65 DB and again amplified 70 DB, so the output of AL2 will be 10 DB higher than the output of AL1. Pads AT12 and AT13 are adjusted to give equal levels at the outputs of all line amps, when input switches are in "simul." position, with normal operating levels. Pads AT13 and AT14 can be adjusted, if necessary, to better suit the local requirements.

## MIXING SYSTEM

The mixing system consists of a ten channel mixer, utilizing ladder type controls connected in a parallel, minimum loss type, mixing circuit.

## VU METER AND ISOLATION PADS

The two VU meters are set up to read "zero" when signal level of +8 VU is being fed into the program line. Isolation pads are placed in each output line to isolate the console circuits from the various telephone line reactances.

## RELAY DECK

Speaker muting relays are mounted on a double sided, etched wiring circuit board. The relays are of a plug-in type and can easily be removed from the console for servicing.

The relays have 4 pole double throw contacts that are connected to mute the studio speakers and connect a 47 ohm load in place of the speakers. The relays also energize the proper warning light in the studio, and mute the intercom speaker to prevent intercom use in a studio with a live microphone. Provision is included for the addition of a fourth relay, if needed. Order Gates stock number 574 0103 000. This relay plugs into the rear socket on the relay deck. Connections to this relay are made on TB6 and TB7. See section on MODIFICATIONS for complete details.

## SPEAKER MATCHING TRANSFORMERS

All house monitor speakers should have matching transformers. These should be 45/50 ohms to voice coil. The output impedance of the monitor amplifiers is 4 to 16 ohms (8 ohms nominal). The parallel combination of the speakers should fall in this range. The 47 ohm back loading resistors, mounted on the relay deck, prevent the load from changing when the speakers are muted.

## REGULATED POWER SUPPLY AND POWER TRANSFORMER

The power supply has two DC outputs. A -37 V unregulated output for the cue-intercom amp, and a -30 V regulated supply for all other circuits. Transistors XQ4, XQ5, and XQ6 amplify any change in output voltage. This sensing signal is then fed to XQ2, which in turn controls the voltage drop across XQ1. XQ1 is in series with the output and maintains a constant voltage with varying load and power line. Zener diodes CR9, CR10 and CR11 provide reference levels for the voltage sensing amplifier.

Overload protection is provided by XQ3 and the associated circuitry. Maximum current out of the power supply is limited to approximately 600 ma. R12 provides for adjusting the output voltage over a small range, to allow for zener diode voltage tolerances. When installing the console, this voltage should be checked and if necessary, R12 readjusted to give -30 volts at the output + and - bus. The console power transformer is designed to mount externally. This prevents the high hum field, surrounding the power transformer, from inducing a high hum level into the low level console circuits. Three independent 28 volt windings are necessary to provide complete isolation between each monitor amplifier and the main console power supply.

## MAINTENANCE

One of the great advantages in the use of transistors is the long life expectancy of semiconductor devices. In this console, high quality components, conservatively rated, have been combined with the latest circuit techniques to give maximum dependability with a minimum of emergency maintenance. However, even the finest equipment may become erratic or inoperative if not properly cared for. We strongly recommend that the station engineer plan a routine preventive maintenance schedule and make every effort to faithfully follow it.

## VOLTAGE MEASUREMENTS

Average voltage readings are given on the schematic diagrams of the various amplifiers. It is recommended that, after the console is installed and operating satisfactorily, these readings be checked and recorded on the schematic. This will provide

the station engineer with a record of the actual voltage readings in his installation, using his meter. If trouble later develops, he will then be better able to judge whether or not a particular circuit is operating properly since he will have available a record of the various readings of his particular equipment. DC readings were taken with a 20,000 ohm/volt meter as indicated on the schematic. RMS signal voltages are shown in parenthesis and must be measured with a vacuum tube voltmeter. If a VTVM is used to measure DC voltages, slightly higher readings may be obtained.

#### MECHANICAL COMPONENTS

The channel mixers are step type low impedance attenuators. If sealed types are used, they require no maintenance. If unsealed types are used, they require cleaning about four times a year in the average location. A well air conditioned room would allow longer periods between cleaning them. A very dusty location would require more frequent cleaning. The attenuator contacts should be cleaned and lubricated by using Davenol (sometimes called Daven oil). A soft, lint-free cloth should be used to remove the dirty accumulation from the contact surfaces. Davenol is inexpensive and may be purchased from the Gates Radio Company.

The relays, and the channel lever keys, were selected for long-life and trouble-free service. The contacts are self-wiping and everyday use will keep these contacts burnished. The contacts on the keys and relays that receive infrequent use can be cleaned by operating the equipment several times, thus, periodic operation of unused equipment will keep the contacts clean. In case of stubborn trouble, use a contact burnishing tool (Gates TM-1). Abrasive papers, files and grease solvents should never be used on these contacts. Grease or oil should not be used on relay or key contacts. This would make them collect dust, get gummy and cause contact burning and possible failure.

The Centralab lever keys have excellent wiping action and will probably not require any cleaning. If one of these keys is damaged, it is better to replace it than to attempt to repair it. Use the parts list for the description, if it is necessary to order a new one.

#### MODIFICATIONS

In the design and construction of the equipment we have tried to provide a console which would give most installations adequate operating facilities. Realizing, however, that some users may require facilities that are not common, we have included in this section information about possible modifications which can be made on the console. Plan your modification carefully and allot sufficient time to complete it so that it will be well executed and will not be a source of trouble.

## PATCH PANEL FACILITIES

All of the important internal circuits of the console are terminated and jumpered on the main terminal board. These jumpers may be removed and normalling jacks wired in place of them. This would permit patching around sections of the console, feeding the console signal to other equipment and feeding signals into selected sections of the console. Of course, any of the inputs or outputs may normal through patch panels before connecting to the external connections. The proper use of patch panels will make the difference between a very versatile and a rather restricted installation. On the other hand, if patch panel facilities are not required, their elimination will reduce the number of possible operational errors. The station engineer must weight all of the factors carefully and act accordingly.

If patch panels are used, they must be wired correctly. They should be wired so that the polarity of the circuits are phased properly in normalling and patching operations. The patch panel should not introduce grounds in any of the circuits, circuits that need ground will have them as explained in the section labeled GROUND CIRCUITS under INSTALLATION.

Circuits of more than 40 DB difference in level should be separated in the patch panels. It is recommended that the jacks be segregated into low level, medium level and high level groups and all wiring attached to the different groups be cabled separately. The cables must have sufficient physical separation to prevent crosstalk as explained in INSTALLATION. If the circuits on the patch panel were located in a progressive order, as located in the console or system, patching would be much easier.

## MUTING RELAYS

An extra socket is provided on the relay deck for a fourth muting relay, if desired. This relay may be wired to mute with the operation of channels 1, 2 or 3 when the lever key is actuated.

The "hot" side of the relay coil appears at terminal 4B on TB6. For operation with S1 (channel 1), connect 4B to 1B on TB6. For operation with S2, connect 4B to 2B on TB6. For operation with S3, connect 4B to 3B on TB6. With the fourth relay (Gates drawing 574 0103 000) in place, warning light connections (1 amp max. load) can be made to terminals 9 and 10 on TB7. Monitor speaker connections may be made on TB6: "Left" spkr. - Terminals 14A-14B; "Right" spkr. - Terminals 15A-15B. The speakers will mute, and the warning lights will operate simultaneously with the other relay already connected to the channel key selected. The fourth relay (as well as the other three relays) may also be wired to operate with external switching, if desired.

Simply connect terminal 4B to one side of the switch and run a lead from the regulated "30 volt bus" on the power supply to the other switch contact. Muting of relays 1, 2 and 3 may be changed, if desired. The "hot" side of relay coils 1, 2 and 3 appear on TB6, terminals 1A, 2A and 3A, respectively. Muting voltage from channel switches S1, S2 and S3 appear on TB6, terminals 1B, 2B and 3B, respectively. To change relay operation, remove the factory installed jumpers and connect the desired relay coil terminal to the desired channel switch terminal. For example, if it is desired to operate relay 3 from channel 1 key switch, jumper TB6-3A to TB6-1B.

#### STEREO NETWORK OPERATION

If it should be desired to operate mixer 9 as a stereo channel the splitting pad (AT27) in the input should be removed and the inputs converted directly into the mixer. Shielded twisted pair should be used for this purpose. Connect TB5 - 17A-17B to the mixer 9 terminals marked IN and C respectively on the rear section of the mixer. Connect TB5 - 18A-18B to the mixer 9 terminals marked IN and C respectively on the front section (closest to the panel) of the mixer. The left program input will then connect to TB5 - 17A-17B. The right program source will connect to TB5 - 17A-18B.

## WARRANTY

This equipment is warranted by Gates Radio Company of Quincy, Illinois to be free from defects in workmanship and material and will be repaired or replaced in accordance with the terms and conditions set forth below:

1. Gates Radio Company believes that the purchaser has every right to expect first-class quality, materials and workmanship and has created rigid inspection and test procedures to that end, and excellent packing methods to assure arrival of equipment in good condition at destination.

2. Gates Radio Company will endeavor to make emergency shipments at the earliest possible time giving consideration to all conditions.

3. Gates Radio Company warrants new equipment of its manufacture for one (1) year, (six (6) months on moving parts), against breakage or failure of parts due to imperfection of workmanship or material, its obligation being limited to repair or replacement of defective parts upon return thereof f.o.b. Gates Radio Company's factory, within the applicable period of time stated. Electron tubes shall bear only the warranty of the manufacturer thereof in effect at the time of the shipment to the purchaser. Other manufacturers' equipment covered by a purchaser's order will carry only such manufacturers' standard warranty. These warranty periods commence from the date of invoice and continue in effect as to all notices, alleging a defect covered by this warranty, received by Gates Radio Company prior to the expiration of the applicable warranty period.

The following will illustrate features of the Gates Radio Company warranty:

Transmitter Parts: The main power or plate transformer, modulation transformer, modulation reactor, main tank variable condensers all bear the one (1) year warranty mentioned above.

Moving Parts: As stated above, these are warranted for a period of six (6) months.

Electron Tubes: As stated, electron tubes will bear such warranty, if any, as provided by the manufacturer at the time of their shipment. Gates Radio Company will make such adjustments with purchasers as given to Gates Radio Company by the tube manufacturer.

All other component parts (except as otherwise stated): Warranted for one (1) year.

Abuse: Damage resulting from abuse, an Act of God, or by fire, wind, rain, hail, in transportation, or by reason of any other cause or condition, except normal usage, is not covered by this warranty.

4. Operational warranty - Gates Radio Company warrants that any new transmitter of its manufacture, when properly installed by purchaser and connected with a suitable electrical load, will deliver the specified radio frequency power output at the output terminal(s) of the transmitter, but Gates Radio Company makes no warranty or representation as to the coverage or range of such apparatus. If a transmitter

does not so perform, or in the event that any equipment sold by Gates Radio Company does not conform to any written statement in a contract of sale relative to its operating characteristics or capabilities, the sale liability of Gates Radio Company shall be, at the option of Gates Radio Company, either to demonstrate the operation of the equipment in conformance with its warranty, or to replace it with equipment conforming to its warranty, or to accept its return, f.o.b. purchaser's point of installation and refund to purchaser all payments made on the equipment, without interest. Gates Radio Company shall have no responsibility to the purchaser under a warranty with respect to operation of equipment unless purchaser shall give Gates Radio Company a written notice, within one (1) month after arrival of equipment at purchaser's shipping point, that the equipment does not conform to such warranty.

5. Any item alleged by a purchaser to be defective, and not in conformance with a warranty of Gates Radio Company shall not be returned to Gates Radio Company until after written permission has been first obtained from the Gates Radio Company home office for such return. Where a replacement part must be supplied under a warranty before the defective part can be returned for inspection, as might be required to determine the cause of a defect, purchaser will be invoiced in full for such part, and if it is determined that an adjustment in favor of the purchaser is required, a credit for an adjustment will be given by Gates Radio Company upon its receipt and inspection of a part so returned.

6. All shipments by Gates Radio Company under a warranty will be f.o.b. Quincy, Illinois or f.o.b. the applicable Gates Radio Company shipping point.

7. Gates Radio Company is not responsible for the loss of, or damage to, equipment during transportation or for injuries to persons or damage to property arising out of the use or operation of Gates equipment. If damage or loss during transportation occurs, or if the equipment supplied by Gates Radio Company is otherwise damaged, Gates will endeavor to make shipment of replacement parts at the earliest possible time giving consideration to all conditions. It is the responsibility of a purchaser to file any claim for loss or damage in transit with the transportation company and Gates will cooperate in the preparation of such claims to the extent feasible when so requested.

8. Gates Radio Company, in fulfilling its obligations under its warranties, shall not be responsible for delays in deliveries due to depleted stock, floods, wars, strikes, power failures, transportation delays, or failure of suppliers to deliver, acts of God, or for any condition beyond the control of Gates that may cause a delayed delivery.

9. This warranty may not be transferred by the original purchaser and no party, except the original purchaser, whether by operation of law or otherwise, shall have or acquire any rights against Gates Radio Company by virtue of this warranty.

10. Gates Radio Company reserves the right to modify or rescind, without notice, any warranty herein except that such modification or rescission shall not affect a warranty in effect on equipment at the time of its shipment. In the event of a conflict between a warranty in a proposal and acceptance and a warranty herein, the warranty in the proposal and acceptance shall prevail.

11. This warranty shall be applicable to all standard Gates catalog items sold on or after March 1, 1960.

12/13/61

THE EXECUTIVE

994 6158 001 STEREO TRANSISTOR CONSOLE

PARTS LIST

<u>Symbol No.</u>	<u>Gates Stock No.</u>	<u>Description</u>
A1, A2, A3, A4	396 0120 000	Lamp, 28 V. #1819
AB1, AB2, AP1, AP2, AP3, AP4, AP5, AP6	994 6034 001	Booster Transistor, Printed Wiring Preamplifier, Plug-in
AL1, AL3	994 5700 001	Transistorized Program Amp., Plug-in
AM1, AM2	994 6108 002	Transistorized Monitor Amp.
AQ1	994 6035 001	Transistorized Cueing Amp., Plug-in
AT1, AT2, AT3	554 0252 000	Dual Attenuator, 600/600
AT4, AT5, AT6, AT7, AT8, AT9, AT10	554-0282-000 554 0253 000	Dual Attenuator, 600/600 W/Cue
AT12, AT16	913 5919 001	"U" Pad Assembly, 34 DB, 15K/300
AT13, AT14	913 5918 001	"U" Pad Assembly, 5400/150, 35 DB
AT15	913 5867 001	Matrix Network Pad Assembly
AT17, AT18	913 5921 001	"U" Pad Assembly, 45 DB, 26K/150
AT19, AT20	913 5922 001	"U" Pad Assembly, 7200/600
AT21	913 6031 002	VU Pad Assembly
AT23	913 6031 001	VU Pad Assembly, 600/600, 6 DB
AT24, AT25 AT26, AT27	913 6033 001 913 5968 001	"H" Pad Assembly, 600/600, 6 DB 2 Way Splitting "T" Pad, 6 DB
C1, C2, C3, C4	506 0005 000	Cap., .1 uf., 200 V.
J1A/B	612 0285 000	Cue Switchboard Jack
J2A/B	612 0355 000	Line Switchboard Jack
J3	612 0368 000	Receptacle
K1, K2, K3, K5	574 0103 000	Plug-in Relay, 4PDT, 24V. DC
LS1	722 0009 000	Speaker, 45 ohm, 3"
M1, M2	630 0105 000	VU Meter, Model 1349 "B" Scale

10/22/62

The Executive  
994 6158 001

PARTS LIST

<u>Symbol No.</u>	<u>Gates Part No.</u>	<u>Description</u>
R1, R2, R9, R13, R14, R21, R25, R26, R33, R40, R44, R53, R57, R68, R72, R81, R85, R91, R98, R99, R128, R129, R130, R135, R136, R142, R146, R150, R155, R160	540 0042 000	Resistor, 510 ohm, 1/2W. 5%
R3, R5, R10, R12, R15, R17, R22, R24, R27, R29, R34, R36, R41, R43, R45, R47, R54, R56, R58, R60, R69, R71, R73, R75, R82, R84, R86, R88, R92, R94, R143, R144, R147, R148, R151, R153, R156, R158, R161, R163	540 0051 000	Resistor, 1200 ohm, 1/2 W. 5%
R4, R11, R16, R23, R28, R35, R37, R38, R42, R46, R48, R49, R50, R51, R55, R59, R61, R62, R63, R64, R65, R66, R70, R74, R76, R77, R78, R79, R83, R87, R89, R93, R107, R108, R110, R113, R116, R119, R152, R157, R162	540 0044 000	Resistor, 620 ohm, 1/2W. 5%
R6, R8, R18, R20, R30, R32	540 0070 000	Resistor, 7500 ohm, 1/2W. 5%
R7, R19, R31	540 0029 000	Resistor, 150 ohm, 1/2W. 5%

10/22/62

-2-

The Executive  
994 6158 001

PARTS LIST

<u>Symbol No.</u>	<u>Gates Stock No.</u>	<u>Description</u>
R39, R52, R67, R80, R90, R95, R131, R132, R133, R134, R141, R145, R149, R154, R159	540 0032 000	Resistor, 200 ohm, 1/2W. 5%
R96, R97	550 0236 000	Master Control, 2500 ohm
R100	550 0237 000	Mon. Gain Dual Control, 2500 ohm
R101, R102, R104	540 0018 000	Resistor, 51 ohm, 1/2W. 5%
R103	540 0039 000	Resistor, 390 ohm, 1/2W. 5%
R105	550 0215 000	Control, 10K ohm
R106, R109, R111, R112, R114, R115, R117, R118	540 0066 000	Resistor, 5100 ohm, 1/2W. 5%
R120, R121, R122, R123, R124, R125, R126, R127	540 0579 000	Resistor, 47 ohm, 2W. 5%, (Part of relay board)
R137, R138, R139, R140	540 0059 000	Resistor, 2700 ohm, 1/2W. 5%
S1, S2, S3, S4, S5, S6, S7, S8, S9, S10	602 0047 000	Lever Key, Series 4803, Pos. 1 Locking, 1A, 1B, 1D Left & Right, Pos. 2, Locking, 1A, 1B, 1D Left & Right
S11, S12, S13, S14, S15, S16, S17, S18, S19, S20, S21, S22, S23, S24, S25, S26, S27, S28, S29, S30, S41, S42	602 0007 000	Lever Switch <i>20<sup>00</sup>-0a</i>
S31, S32, S33, S34, S36, S37	602 0005 000	Lever Switch
S35	600 0201 000	Mon. Selector Switch
S38	600 0219 000	Intercom Selector Switch
S39	600 0213 000	VU2 Selector Switch
S40	600 0218 000	Phone Selector Switch
S43	604 0230 000	Pushbutton Switch, SPST, N.O.

10/22/62

-3-

The Executive  
994 6158 001

PARTS LIST

<u>Symbol No.</u>	<u>Gates Stock No.</u>	<u>Description</u>
T1, T5, T6, T7, T8, T9, T10	478 0009 000	Audio Transformer, A21
T2, T4	478 0230 000	Speaker Transformer, A-36283
T3	478 0231 000	Speaker Transformer, A-36792
T11	472 0429 000	Power Transformer, A-36766
TB1, TB2, TB3, TB4, TB5, TB6	614 0434 000	Terminal Block, 20 pair
TB7	614 0054 000	Terminal Board
TB8	614 0050 000	Terminal Board
XA1, XA2, XA3, XA4	406 0317 000	Pilot Light Socket
XK1, XK2, XK3, XK4	404 0161 000	Relay Socket (Part of relay board)
XK5	404 0160 000	Relay Socket

PARTS LIST

M6205 TRANSISTOR  
REGULATED POWER SUPPLY

<u>Symbol No.</u>	<u>Gates Stock No.</u>	<u>Description</u>
C1, C2	522 0268 000	Cap., 20 mfd., 100(W)V.
C3	524 0100 000	Cap., 1000 uf., 50 V.
C4	506 0005 000	Cap., .1 mfd., 200 V.
C5	522 0297 000	Cap., 250 mfd., 50(W)V.
C6	522 0321 000	Cap., 500 uf., 50 V.
CR1, CR2, CR3, CR4, CR5, CR6, CR7	384 0062 000	Silicon Rectifier, X5A2
CR8, CR9, CR10, CR11	386 0014 000	Zener Diode
F1	398 0017 000	Fuse, 1 amp., 250 V.
Q1, Q3	380 0016 000	Transistor, 2N1539
Q4	380 0013 0009	Transistor, 2N1225
Q2, Q6	380 0014 000	Germanium Transistor, 2N1414
Q5	380 0011 000	Transistor, 2N214
R1, R5, R8, R11	540 0073 000	Res., 10K ohm, 1/2W., 5%
R2	540 0066 000	Res., 5100 ohm, 1/2W., 5%
R3	542 0696 000	Res., 51 ohm, 1 W., 5%
R4	540 0623 000	Res., 3300 ohm, 2 W., 5%
R6, R7, R9	540 0071 000	Res., 8200 ohm, 1/2W., 5%
R12	550 0217 000	Sub-miniature Potentiometer, 2K ohm, 1/4 W.
R10	540 0059 000	Res., 2700 ohm, 1/2W., 5%
R13	540 0058 000	Res., 2400 ohm, 1/2 W., 5%
R14	540 0570 000	Res., 20 ohm, 2 W., 5%
TB1	614 0112 000	Terminal Board
TB2		Terminal Board (Part of Mech. Assy.)
XCR8, XCR9, XCR10, XCR11, XQ2, XQ4, XQ5, XQ6	404 0066 000	Socket
XF1	402 0076 000	Dual Fuse Block
XQ1, XQ3	404 0136 000	Transistor Mtg. Kit

11/19/62

-5-

M6158 "EXECUTIVE"  
STEREO CONSOLE

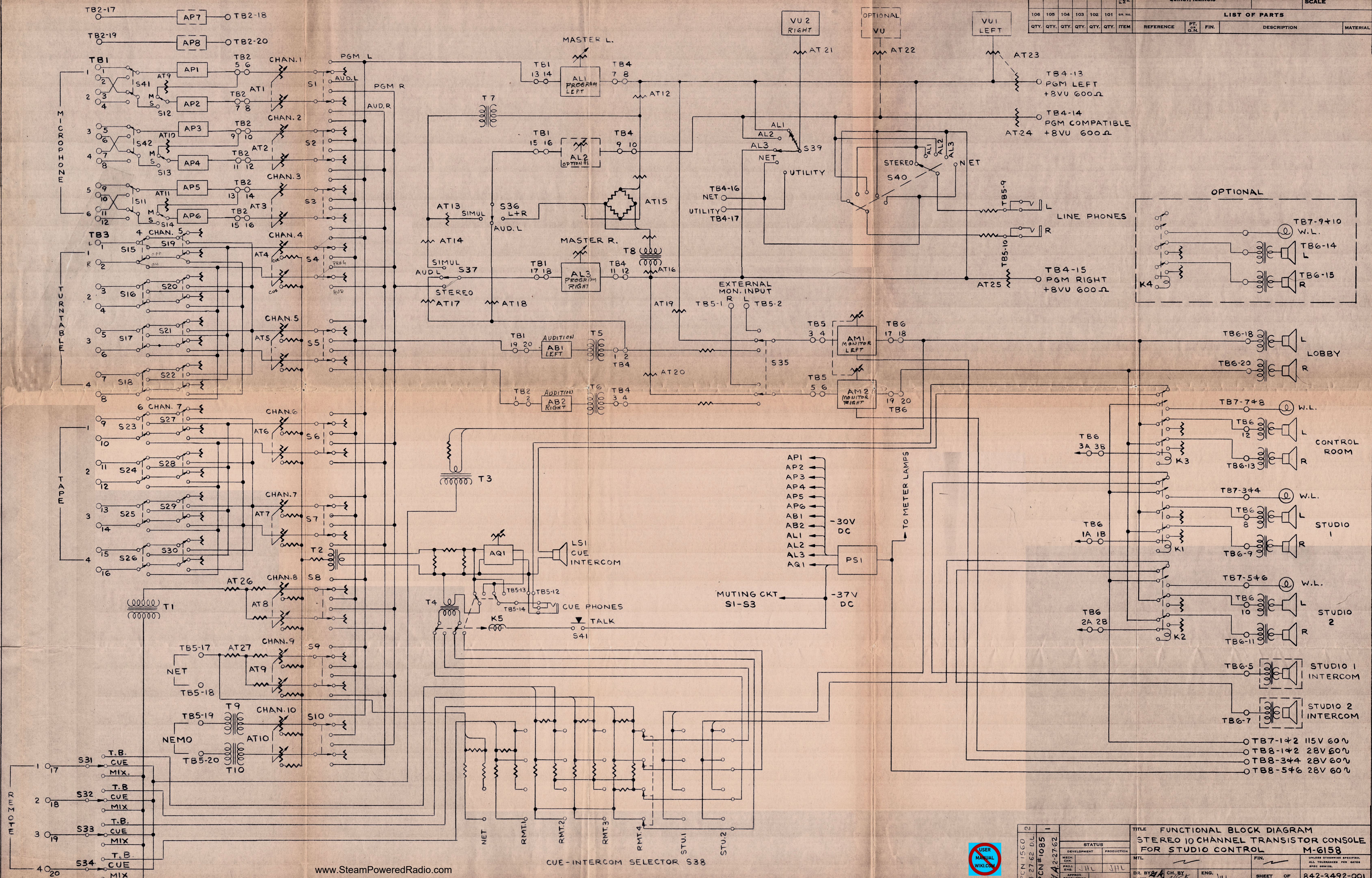

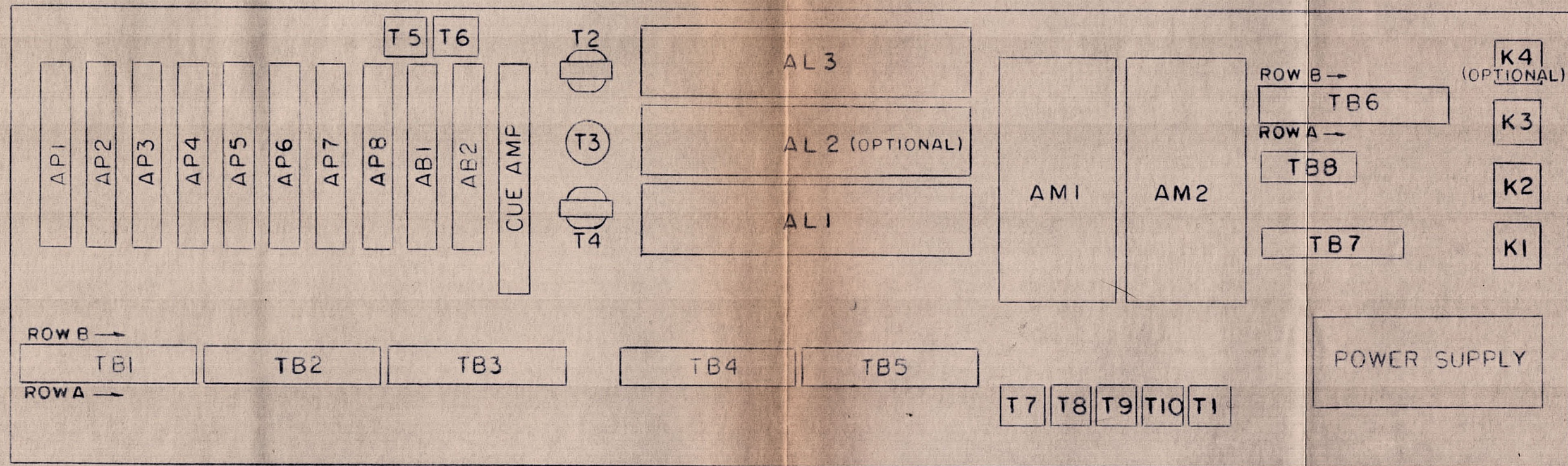

FRONT

*JHL*

104 103 102 101 GR. FIRST MADE FOR NO.

LIST OF PARTS

QTY.	QTY.	QTY.	ITEM	REFERENCE	PT. OR G.N.	FIN.	DESCRIPTION	MATL.
------	------	------	------	-----------	-------------	------	-------------	-------

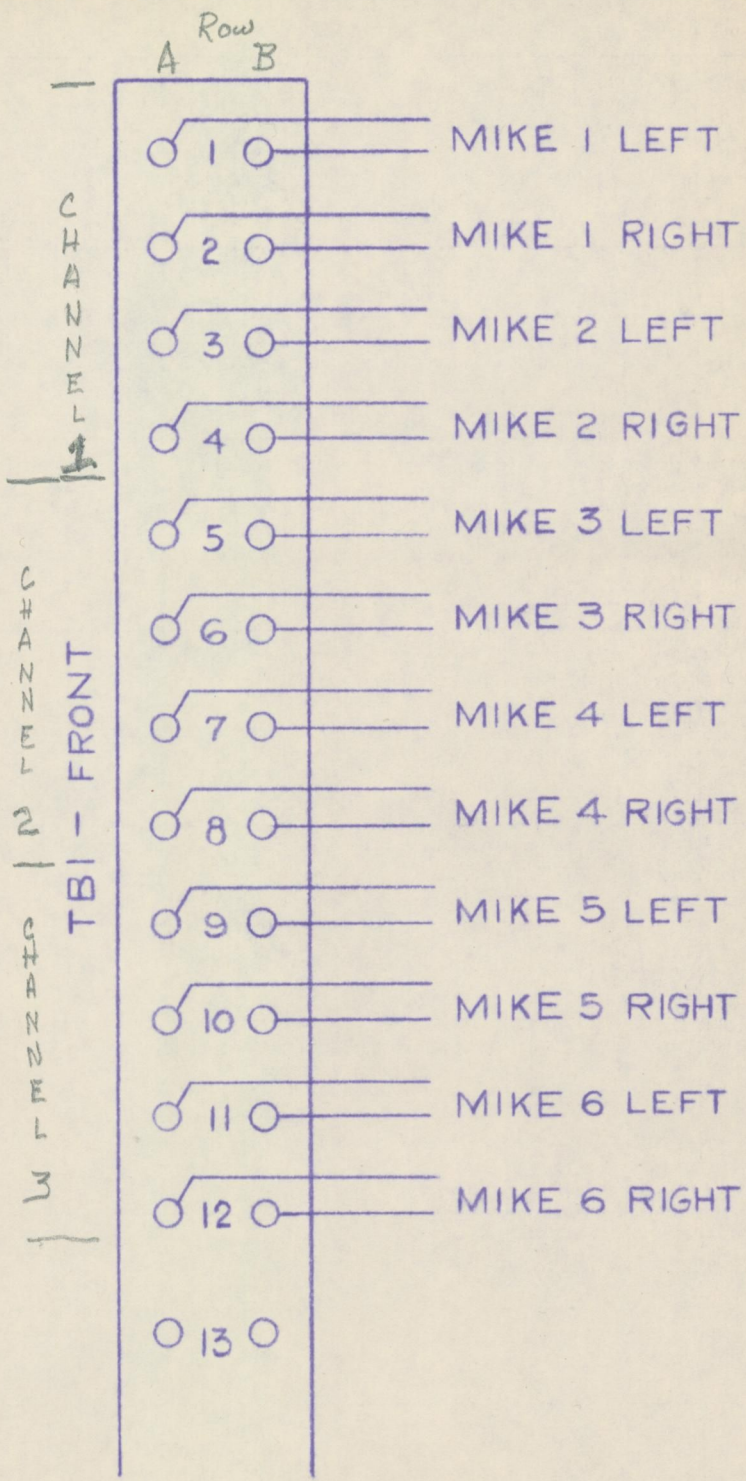

STATUS	
DEVELOPMENT	PRODUCTION
MECH. CHK.	
PROJ. ENG.	
DEV. BY	
FUNCTION BY	

www.SteamPoweredRadio.com

CH. BY	MTL.	TITLE MICROPHONE INPUT CONNECTIONS M6158 STEREO CONSOLE	UNLESS OTHERWISE SPECIFIED, ALL TOLERANCES PER GATES SPEC GSM102.
DATE			
DR. BY HBC	ENG. JAL	FIN.	813-7290-001
DATE 3/6/62			

104	103	102	101	GR. NO.	LIST OF PARTS				
QTY.	QTY.	QTY.	QTY.	ITEM	REFERENCE	PT. OR G.N.	FIN.	DESCRIPTION	MATL.

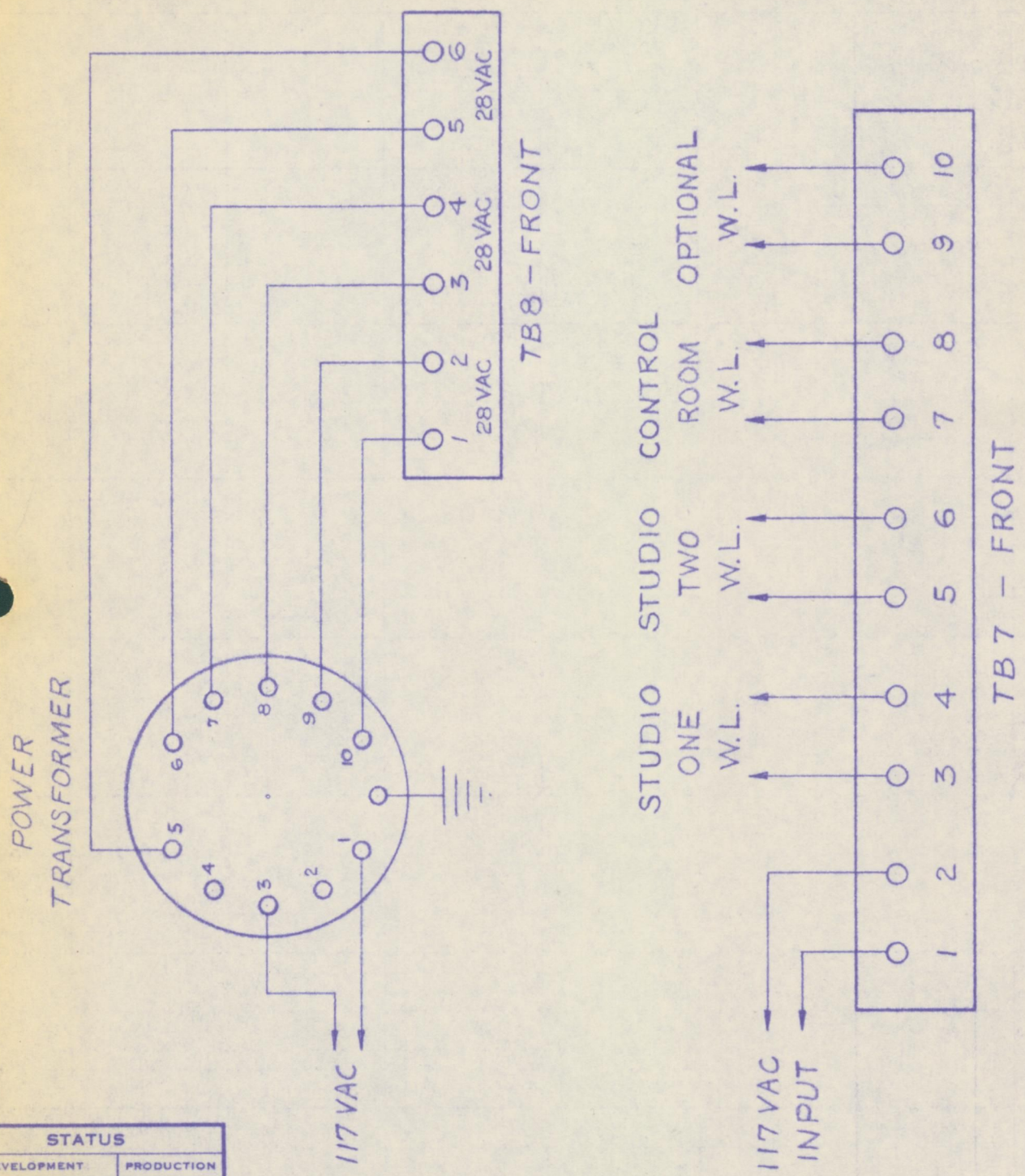

STATUS	
DEVELOPMENT	PRODUCTION
MECH. CHK.	
PROJ. ENG.	
APPROV. BY	

CH. BY	MTL.		
DATE			
DR. BY HBC	ENG. JHL	FIN.	
DATE 2/5/62			

TITLE *POWER TRANSFORMER AND  
WARNING LIGHT CONNECTIONS  
M-6158 STEREO CONSOLE*

UNLESS OTHERWISE SPECIFIED,  
ALL TOLERANCES PER GATES  
SPEC GSM102.

813-7289-001

LIST OF PARTS

QTY.	QTY.	QTY.	ITEM	REFERENCE	PT. OR G.N.	FIN.	DESCRIPTION	MATL.
------	------	------	------	-----------	-------------	------	-------------	-------

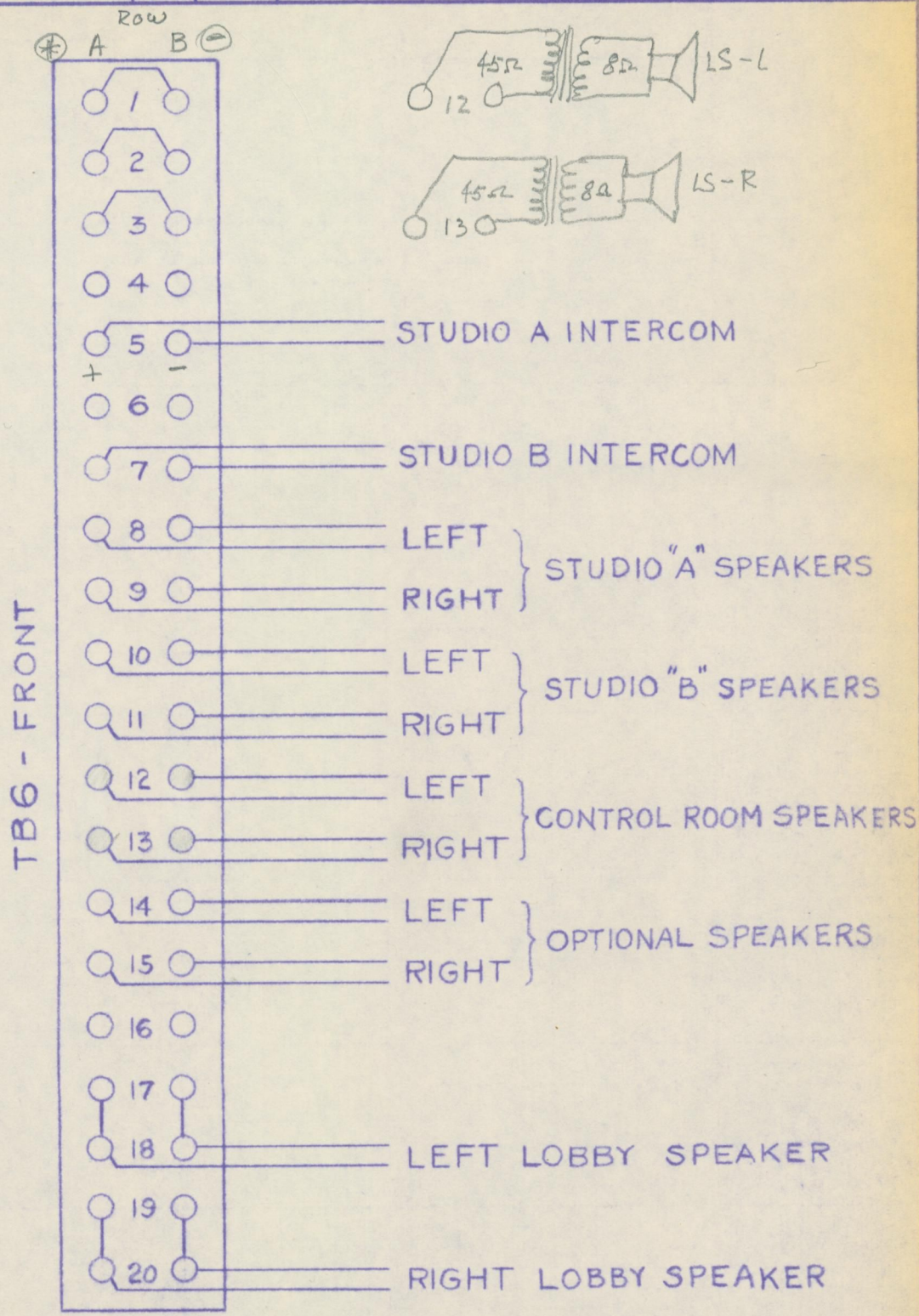

STATUS	
DEVELOPMENT	PRODUCTION
MECH. CHK.	
PROJ. ENG.	
APPROV. BY	

CH. BY	MTL.	TITLE MONITOR SPEAKER CONNECTION - STEREO CONSOLE M6158	UNLESS OTHERWISE SPECIFIED, ALL TOLERANCES PER GATES SPEC GSM102. 813-7300-001
DATE			
DR. BY HBC	ENG. JHL	FIN.	
DATE 3/7/62			

GATES RADIO COMPANY  
QUINCY ILLINOIS

813-7300-001  
SCALE NONE

LIST OF PARTS

QTY	QTY	QTY	QTY	ITEM	REFERENCE	PT. NO.	FIN.	DESCRIPTION	MATL.
-----	-----	-----	-----	------	-----------	---------	------	-------------	-------

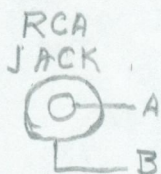

TB 3 FRONT

CHANNEL	A	B	DESCRIPTION
CHANNEL 4	1	0	T.T. 1 LEFT
	2	0	T.T. 1 RIGHT
	3	0	T.T. 2 LEFT
	4	0	T.T. 2 RIGHT
CHANNEL 5	5	0	T.T. 3 LEFT
	6	0	T.T. 3 RIGHT
	7	0	T.T. 4 LEFT
	8	0	T.T. 4 RIGHT
CHANNEL 6	9	0	TAPE 1 LEFT
	10	0	TAPE 1 RIGHT
	11	0	TAPE 2 LEFT
	12	0	TAPE 2 RIGHT
CHANNEL 7	13	0	TAPE 3 LEFT
	14	0	TAPE 3 RIGHT
	15	0	TAPE 4 LEFT
	16	0	TAPE 4 RIGHT
CHANNEL 8	17	0	REMOTE LINE 1
	18	0	REMOTE LINE 2
	19	0	REMOTE LINE 3
	20	0	REMOTE LINE 4

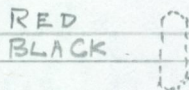

TB.3

STATUS	
DEVELOPMENT	PRODUCTION
MECH	
CHK	

CH. BY DATE	MTL,	TITLE: TURNTABLE & TAPE INPUTS	
DR. BY DATE	ENG. DTG	FIN.	CONNECTION-STEREO CONSOLE UNBALANCED M 6158
			813-7300-001

GATES RADIO COMPANY  
QUINCY, ILLINOIS

813-7721-001

SCALE

104	103	102	101	GR. NO.	FIRST MADE FOR
QTY.	QTY.	QTY.	QTY.	ITEM	REFERENCE

LIST OF PARTS

QTY.	QTY.	QTY.	QTY.	ITEM	REFERENCE	PT. OR G.N.	FIN.	DESCRIPTION	MATL.
------	------	------	------	------	-----------	-------------	------	-------------	-------

TOP

REAR  
VIEW  
JACK PLATE

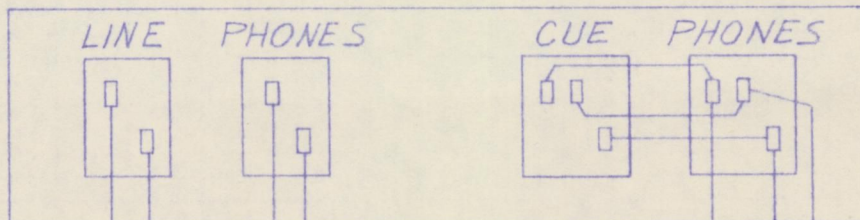

TO TB5-10A

TO TB5-10B

TO TB5-9B

TO TB5-9A

TO TB5-14A

TO TB5-13B

TO TB5-13A

NOTE: WHEN INSTALLING EXTERNAL CUE PHONES, REMOVE JUMPER ON TB5 BETWEEN 13A AND 14A BEFORE CONNECTING LEADS FROM PHONE JACK

STATUS	
DEVELOPMENT	PRODUCTION
MECH. CHK.	
PROJ. ENG.	
PROV. SECTION BY	

www.SteamPoweredRadio.com

CH. BY <i>JA</i>	MTL.	TITLE EARPHONE JACK CONNECTIONS 10 CH. STEREO TRANSISTOR CONSOLE M-6158	UNLESS OTHERWISE SPECIFIED, ALL TOLERANCES PER GATES SPEC GSM102.
DATE 6-29-62			
DR. BY <i>W</i>	ENG <i>JVL</i>	FIN.	813-7721-001
DATE 6-29-62			

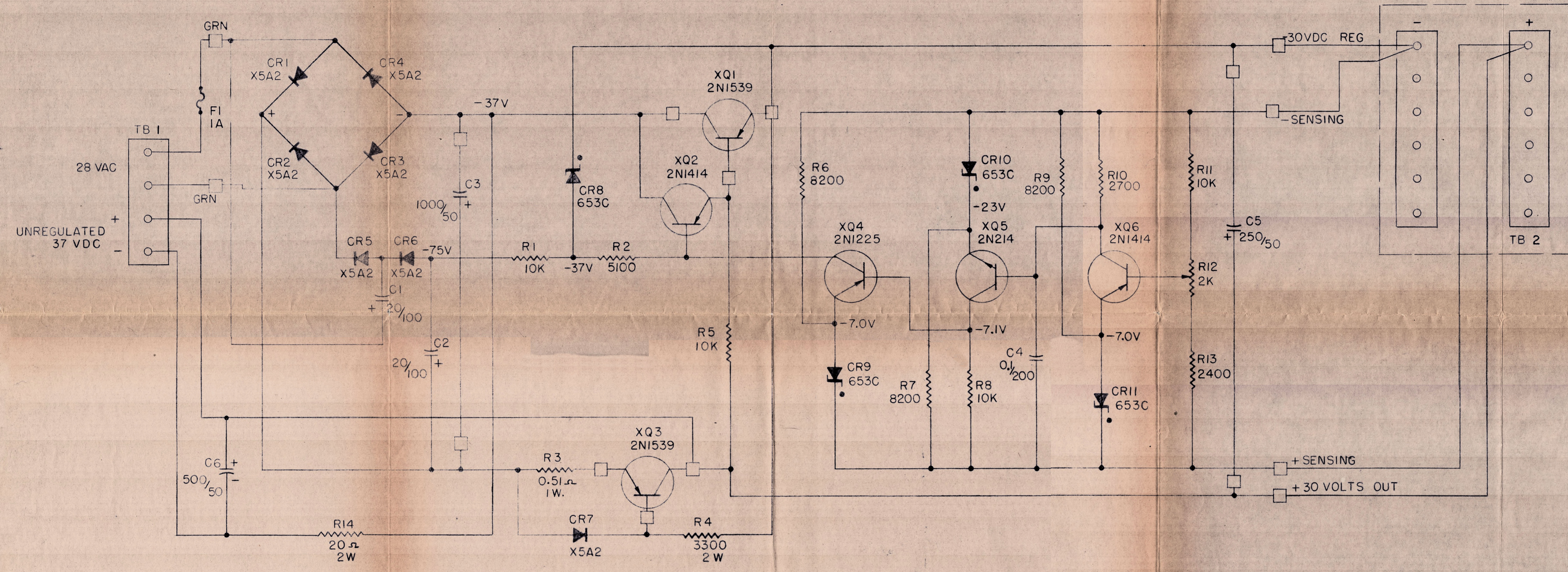

1. ALL RESISTORS 1/2 WATT 5% EXCEPT WHERE NOTED.
2. ALL CAPACITANCE IN MFD., WITH D.C.W.V.
3. DC VOLTAGES MEASURED WITH 20K Ω/VOLT METER.
4. R7 IS ADJUSTED TO PROVIDE -30V OUTPUT.
5. □ DESIGNATES BOARD LUG CONNECTIONS.
- 6 LAST R NO 14
- 7 LAST C NO 6

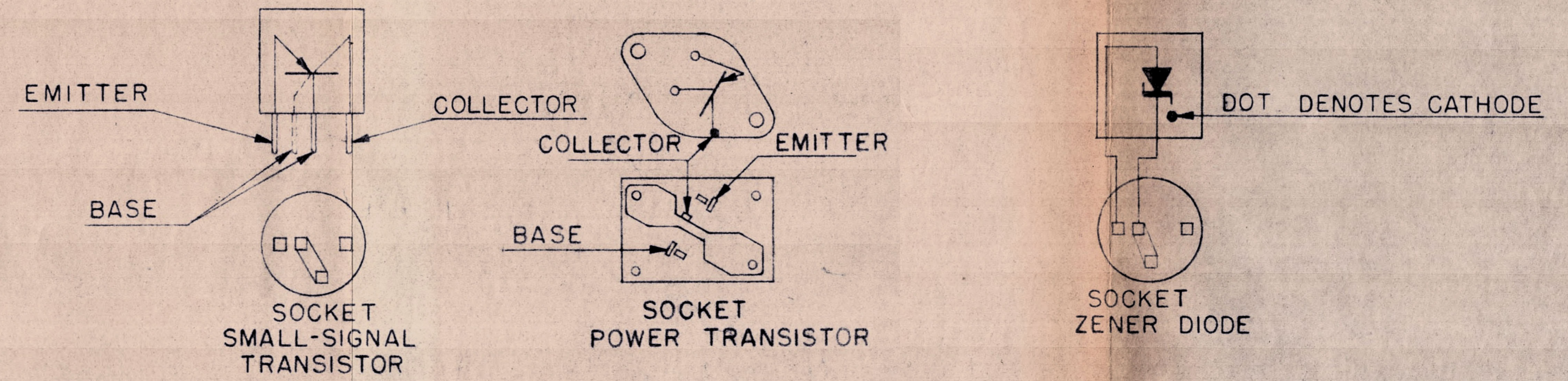

TITLE		TRANSISTOR REGULATED POWER SUPPLY STEREO CONSOLE M6205	
STATUS		DEVELOPMENT PRODUCTION	
RECH. CODE	PROJ. ENG.	APPROV. PRODUCTION BY	DATE
DR. BY: JWC	H. BY: INGRAM	ENG. Jambert	SHEET OF 842-3485-001
FIN.		UNLESS OTHERWISE SPECIFIED: ALL DIMENSIONS PER GATES SPEC. DRAWING	

**GATES**



**M 5700  
TRANSISTOR  
PROGRAM AMPLIFIER**



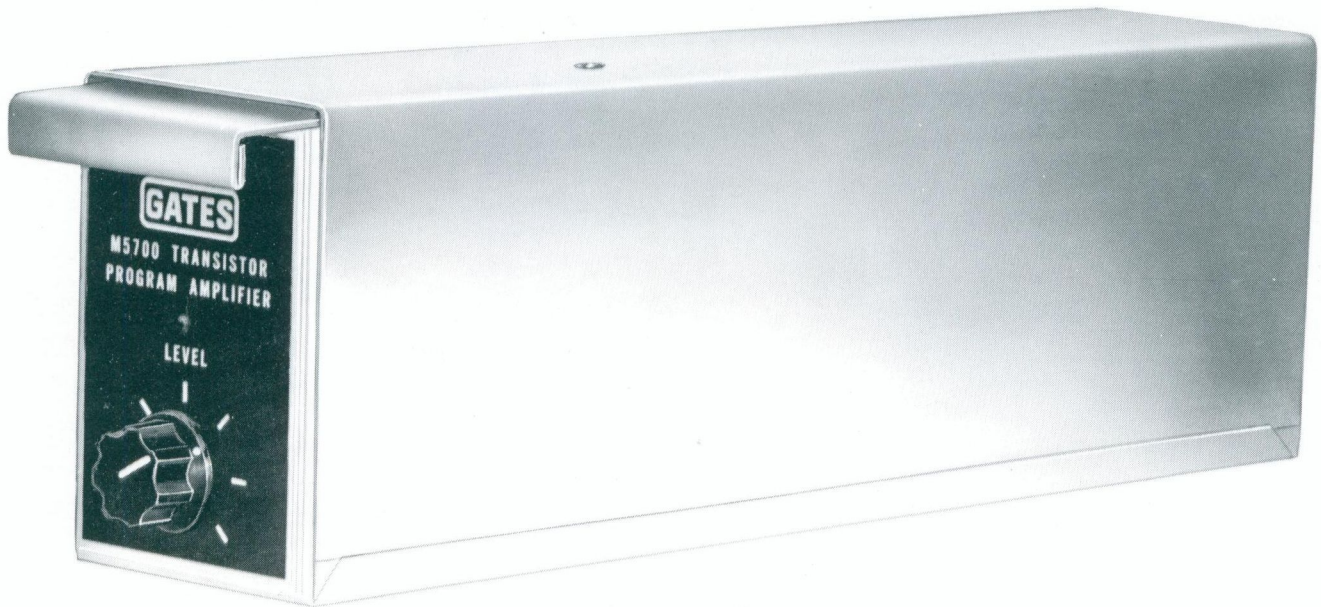

Fig. 1 - M5700 Transistor Program Amplifier

The Gates Transistor Program Amplifier is available in three versions:

1. The M5700 is designed specifically for use in Gates Transistor Consoles. It is supplied less the interstage level control, and with the input unterminated. The control is mounted externally on the Console panel.
2. The M5700A is designed for rack mounting in system applications, and has the level control mounted internally and the input terminated.
3. The M5700B is identical to the M5700A except that the input is unterminated.

#### TECHNICAL DATA

<p>Gain: 80 db, may be reduced as required with internal volume control.</p>	<p>wave power output, using 40 and 7000 cps., mixed 4:1. Under 1.5% at +24 dbm.</p>
<p>Frequency Response: +1 db from 30 to 15,000 cps.</p>	<p>Noise Level: -115 dbm equivalent input noise.</p>
<p>Harmonic Distortion: Under 0.75% at 30 cps., 0.5% from 50 to 15,000 cps., at +24 dbm output.</p>	<p>Source Impedance: 150/250 ohms, or 500/600 ohms.</p>
<p>Intermodulation Distortion: Under 0.3% at +14 dbm equivalent sine</p>	<p>Input Impedance: Factory connected for 150 ohms. May also be connected for 600 ohms.</p>

**Load Impedance:**

Factory connected for 600 ohms. May also be connected for 150 ohms.

**Maximum Input Level:**

-35 dbm.

**Maximum Output Level:**

+24 dbm.

**Maximum Operating Ambient Temperature:**

55° C. (131° F.)

**Maximum Storage Ambient Temperature:**

85° C. (185° F.)

**Power Requirements:**

30 volts D.C., 90 ma., 0.1 mv. maximum ripple.

**Transistors:**

5 - 2N1414            1 - 2N422  
1 - 2N1183

**Finish:**

Cadmium plated cover, black escutcheon plate.

**Mounting:**

M6031 Mounting Tray required to mount in M6029 Shelf Assembly. Shelf assembly accommodates seven Program Amplifiers and requires panel space of 3-1/2" X 19".

**Size:**

2-7/32" wide, 3-1/8" high, 10-3/4" long, overall.

**Weight:**

4-1/4 lbs. net. 8-1/4 lbs. packed.

**Cubage:**

0.8 cu. ft. domestic pack.

### DESCRIPTION

The M5700 Program Amplifier is completely transistorized, and is designed for use as a line or isolation amplifier in broadcasting and recording applications. Special techniques have been employed to obtain low noise, low distortion, and good temperature stability.

The amplifier is used with the M6031 Mounting Tray which carries a mating receptacle and is supplied with mounting hardware. Up to seven trays may be installed on the M6029 Shelf Assembly, which mounts in a standard Gates rack cabinet, and occupies 3-1/2" of panel space. A keying pin is pro-

vided with the mounting tray to prevent accidental interchange of non-similar plug-in units in the system.

On the front panel of the A and B models is located the interstage level control. The output transformer and receptacle are attached to the frame, and all other components are mounted on the printed wiring boards.

Typical frequency response and distortion curves are shown in Fig. 2. These measurements were taken with all transistors selected at random.

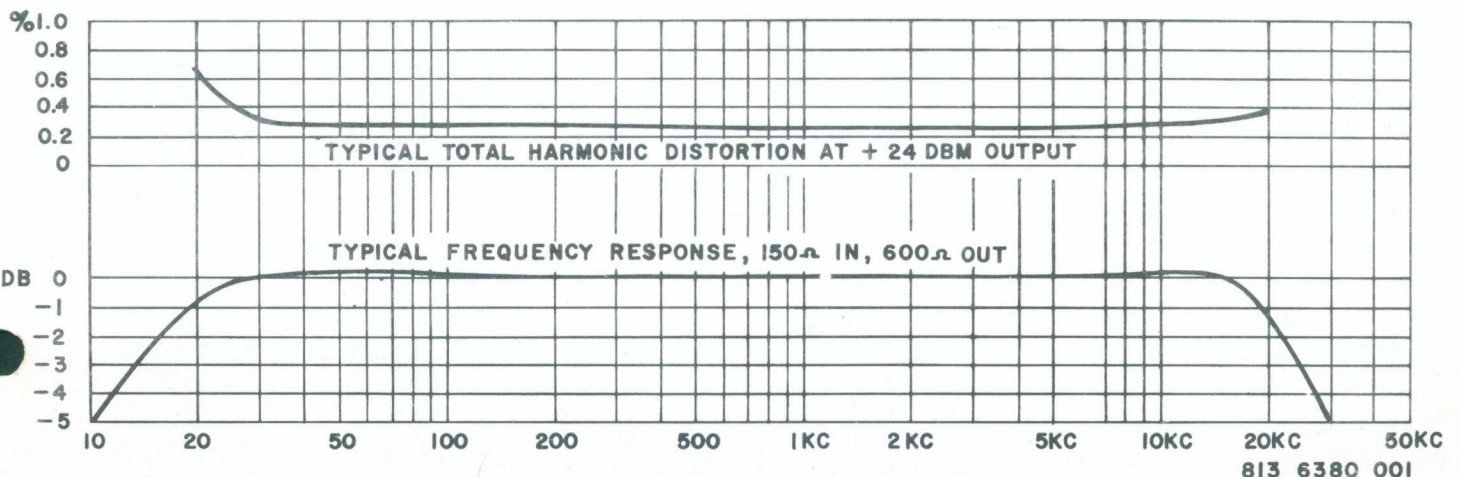

## INSTALLATION

### MOUNTING TRAY AND SHELF ASSEMBLY

Mounting holes have been spaced in the shelf assembly to allow it to be completely filled with trays of any one type for the Gates transistorized units. It is possible, where maximum use of shelf space is not required, to mix trays of different sizes. Thus a program amplifier and preamplifier could be placed at the left and a power supply at the extreme right. Proceed as follows:

1. Locate the first tray at the extreme left or right of the shelf assembly, with the receptacle at the rear. The countersunk holes of the tray will fit into the matching holes in the shelf, when properly located. Leave a 1/16" space between trays.
2. Secure the tray to the shelf with the two #4-40 x 1/4" flat head screws with the two #6 internal-external shakeproof washers under two #4 hex nuts.

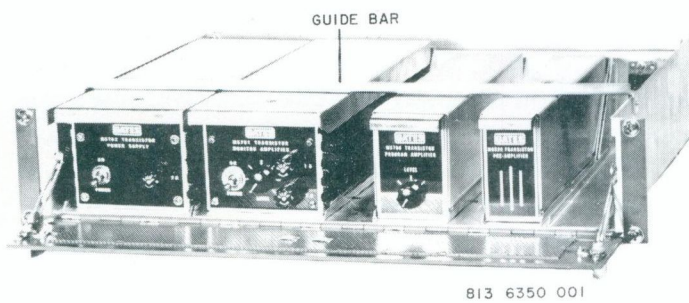

Fig. 3 - Shelf Assembly With Guide Bar

3. Determine whether or not the guide bar, shown in Fig. 3, will be required. The purpose of this bar is to prevent possible damage to the mating connectors when upward pressure is inadvertently applied to the amplifier during withdrawal. The bar will be required only where no other protecting obstruction is present in the rack, or where the shelf is used at a location such as a work bench.

It will not be required where another M6029 Shelf Assembly is mounted directly above,

or where overhead equipment interferes with mounting of the shelf due to the presence of the bar. The mounting screws are located so that they may be removed from within the shelf.

4. Mount the shelf in the rack using hardware supplied with the rack. The two end strips mount under the screw heads, and are to be flush with the drop panel.

### INPUT AND OUTPUT TRANSFORMERS

The input transformer is factory connected for 150 ohms primary impedance, as shown on the schematic diagram and on Fig. 4. Refer to Fig. 4 for connections for 600 ohms impedance. Note that the input terminating resistor, R31, must be changed to 620 ohms when making this change.

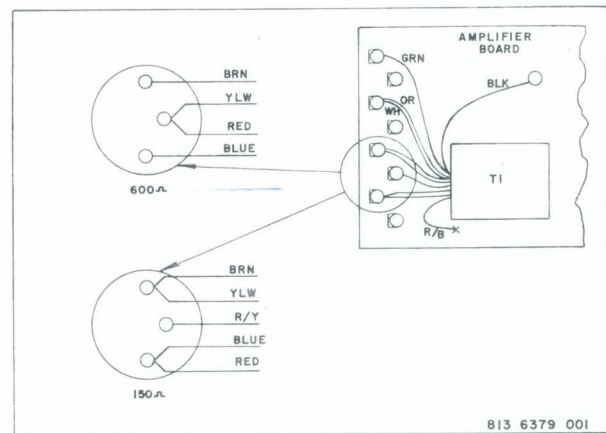

Fig. 4 - Input Transformer Connections

Where it is desired to use the M5700A Program Amplifier with an unterminated input remove R31, which is a 150 ohm resistor connected directly between the input lugs on the preamplifier printed board. Also change R1 from 620 ohms to 240 ohms. Location of these resistors may be determined from the component location drawing, Fig. 6.

Both the M5700 and M5700B models have these changes incorporated.

The output transformer is factory connected

for 600 ohms secondary impedance. To re-connect for 150 ohms refer to the schematic diagram. Remove the green/white and black wires from terminal #7. Connect the black wire to terminal #5 and the green/white wire to terminal #6.

### EXTERNAL CONNECTIONS

External connections are made to the mounting tray receptacle as follows:

<u>Circuit</u>	<u>Terminals</u>
External Control (Optional)	1, 2, 3
+30 V.	4
Circuit Ground	4
Output Connections	5, 6
Output Center-Tap (600 ohms)	7
Input Connections	9, 10
Input Center-Tap	11
-30 V.	12
Chassis Ground	13
No Connection	8, 14, 15, 16

Jumper together all #13 terminals on the shelf, whether program amplifiers or other types, and connect to the rack ground bus. Connection from rack ground to the circuit ground in the program amplifier (B+) should be made at the amplifier (not at the power supply). Make a connection from the rack ground bus to each amplifier terminal #14, SEPARATELY, with at least 18 gauge wire. These circuit grounds must be carried separately to prevent the possibility of interac-

tion (due to mixing of return currents in a common wire). Where other types of amplifiers are mounted on the same shelf, consult their respective Instruction Book for grounding information. Where many amplifiers and power supplies are mounted in a rack, it is preferable to run a vertical rack ground bus-bar, to pick up grounds at each shelf.

Run the D. C. supply leads, output pair, and chassis and circuit ground leads along the rear edge of the shelf. The D.C. supply leads should be at least 18 gauge, and must be run SEPARATELY from each program amplifier to its respective power supply, to prevent the possibility of common coupling in the power wiring. See the power supply Instruction Book for further information.

Run input pairs and external control leads along the shelf brace, above the receptacles.

### EXTERNAL VOLUME CONTROL

Reference to the schematic diagram will indicate that the program amplifier is wired to accommodate an external volume control. This feature makes it possible to locate the volume control on an adjacent rack panel, or on a console control panel, when the amplifier is mounted internally. The internal control, R30, must be disconnected when the amplifier is to be used in this way. The (R30) control may be ordered as part number 550 0218 000.

### THEORY OF OPERATION

For the purpose of explanation, the program amplifier can be considered to be made up of two parts: the preamplifier, and the high level amplifier.

#### THE PREAMPLIFIER

The four stage preamplifier has a transformer coupled input and emitter follower output, with direct coupling utilized between Q1 and Q2, and between Q3 and Q4. The first stage transistor is a low noise type de-

signed for use in critical low noise applications.

Biasing is accomplished by a combination of voltage divider and emitter resistance, as with R2, R3, and R5. This method of biasing also insures a high degree of temperature stability. Signal degeneration is provided for Q1 by R6, and for Q3 by R17. A loop feedback network connects from Q3, thru R7 and C5, to Q1. The large amount of feedback and degeneration obtained by these

T1 PRIMARY

IMP.	C.T.	JOIN	CONNECT TO	R31
600Ω	YEL	TO RED	BLUE & BRN.	620Ω
15Ω	R/Y	BLUETO RED YEL TO BRN.	BLUE & BRN.	150Ω

T2 SECONDARY

IMP.	C.T.	JOIN	CONNECT TO
30Ω	GRN/BLK	3, 4, 7, 8, 9	GRN & YLW
15Ω	-	GRN TO YLW GRN TO BLK	GRN & YLW

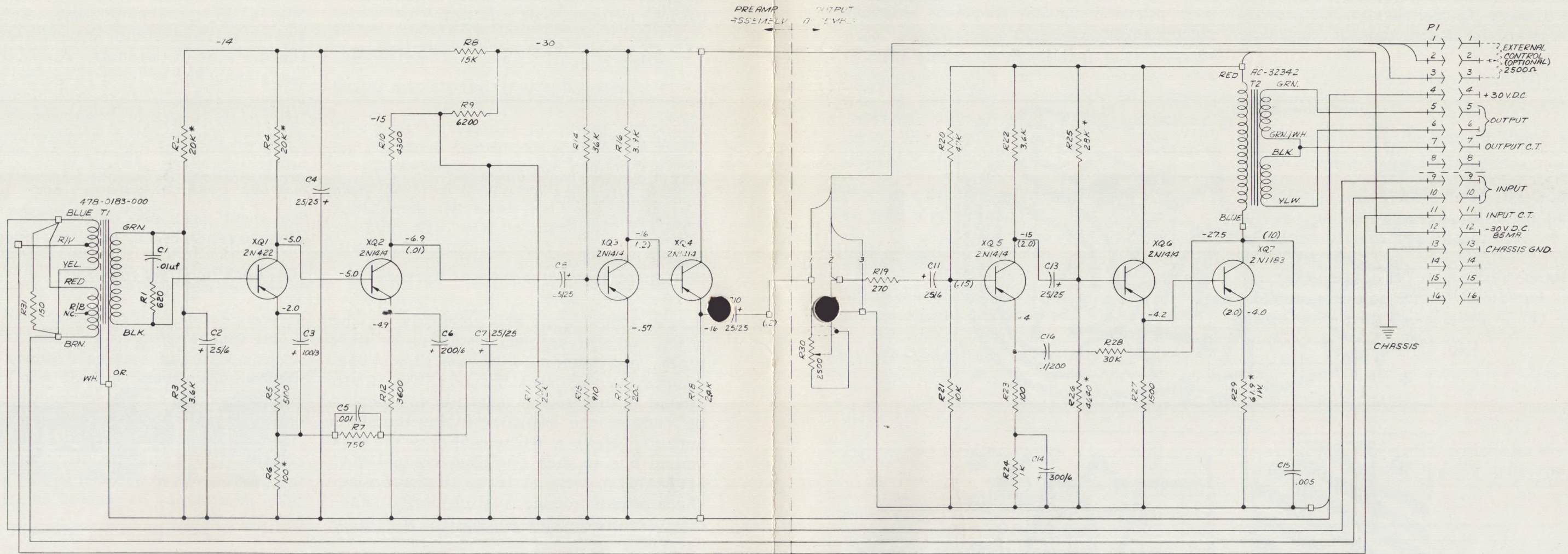

- (1) D.C. VOLTAGES MEASURED WITH 20K Ω-VOLT METER.
- (2) ( ) R.M.S. SIGNAL VOLTAGE AT 1KC, -5dBm IN, +24 DBM OUT.
- (3) ALL RESISTORS 1/2 WATT, 5% EXCEPT \* 1% AND WHERE NOTED.
- (4) ALL CAPACITORS IN MFD, WITH D.C. W.V.
- (5) □ DESIGNATES BOARD LUG CONNECTION.
- (6) FOR M5700B MODEL DELETE R31



methods reduces distortion in the preamplifier to an extremely low value, and makes the operation almost completely independent of variations in transistor parameters.

### THE HIGH LEVEL AMPLIFIER

The output stage, Q7, is connected in the common emitter configuration, with a series fed output transformer, T2, in the collector circuit. Emitter resistor R29 provides a large amount of degeneration, to reduce

large-signal distortion to a low value.

The low driving impedance required by a stage of this type is obtained from the emitter follower, Q6. The stages are direct coupled, with R25 and R26 establishing the bias on both Q6 and Q7. Q5 provides additional gain for the high level amplifier.

The feedback network, R28 and C16, is used primarily for low frequency response compensation.

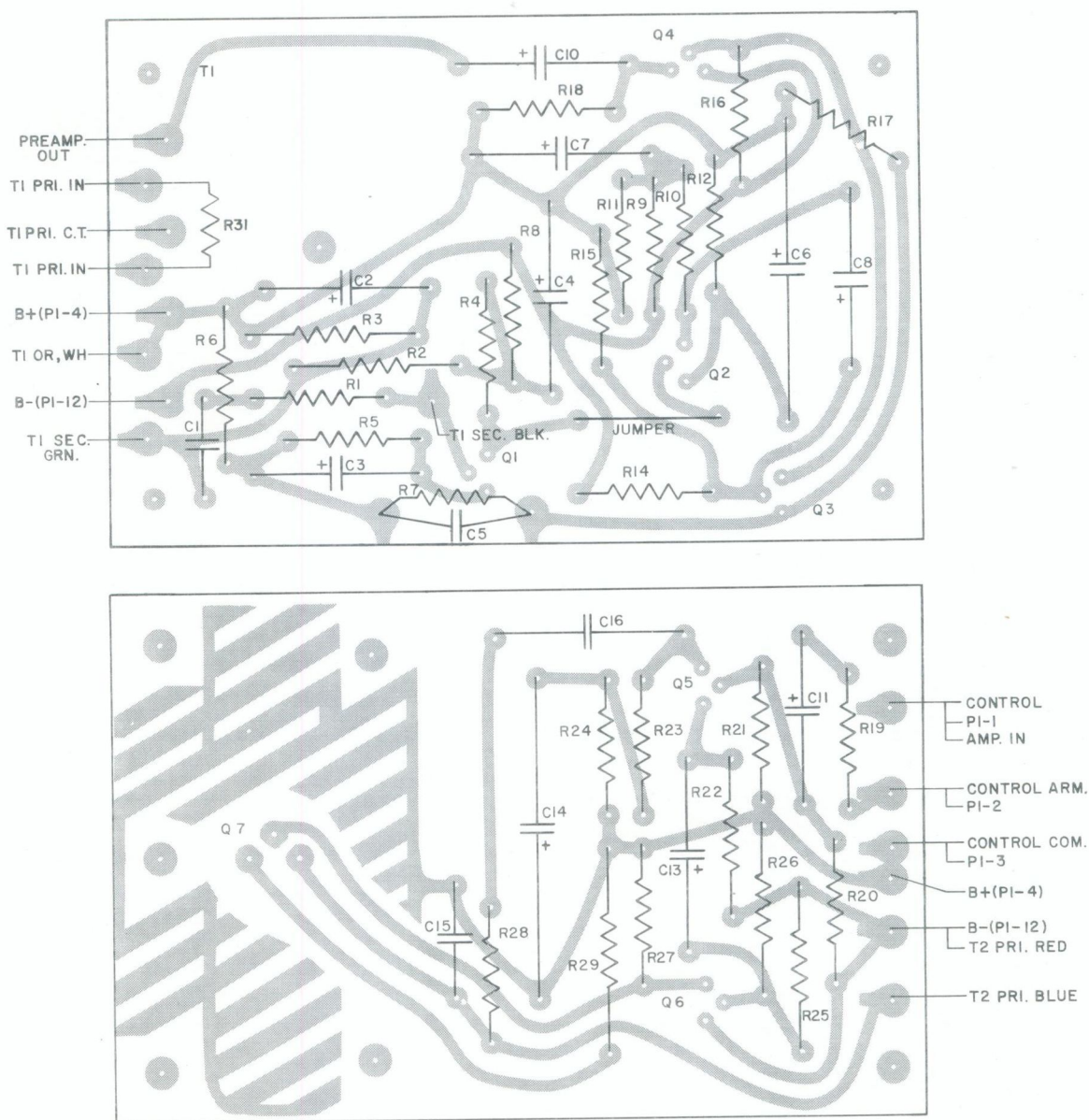

Fig. 6 - Printed Board Component Location, Viewed from Wiring Side.

## MAINTENANCE

### PREVENTIVE MAINTENANCE

The M5700 Program Amplifier is designed for long, trouble-free service. However, as with all high quality electronic equipment, a regular program of inspection should be followed.

It is recommended that when the amplifier is first placed in operation, D.C. voltage be measured with the same voltmeter that will be used for maintenance and trouble shooting, and that these readings be recorded on the amplifier schematic above the typical voltage shown.

Dust and dirt should be periodically removed with a soft brush.

### SERVICING

When servicing the amplifier, the following points should be observed:

1. The condition of the output stages, Q7

and Q6, can be most readily checked by measuring the D. C. voltages associated with these stages.

2. Circuit resistances should be measured only after removing the associated transistor or transistors, to prevent damage due to ohm-meter battery voltage.

3. Do not remove or insert transistors with the power on.

4. Do not probe the printed board with a metal probe with the power on.

5. Circuit voltages are reversed from standard vacuum tube practice, as is the polarity of all the electrolytic capacitors.

6. The location of the positive end of each electrolytic capacitor is indicated by the white dot marked on the top of the circuit board.

## PRINTED CHASSIS COMPONENT REPLACEMENT

### CHECKING COMPONENTS

1. The components should be carefully checked by measuring circuit voltages and resistances before attempting to remove one of the leads from the printed chassis. Extreme care must be exercised in removing the lead to prevent damage to the board or conductors. This operation should not be considered unless it is the only way the component can be checked. If one lead must be removed without damage to the component, apply a well cleaned and tinned 25 to 60 watt iron to the fillet adjacent to the lead. With small long nose pliers or thin screwdriver, pry the folded portion of the lead in line with the holes. Applying the iron for more than four seconds at a time may damage the chassis base material.

Remove as much solder from the lead as

possible. Remove all the kinks in the wire. With heat applied, gently pull the wire through the hole.

### RESOLDERING THE COMPONENT

2. If the component is good, replace as follows: Use a metal twist drill (1/8" dia. or less) to clear the hole only in the fillet of solder. Turn with the fingers only remove solder slowly to prevent the drill from tearing the fillet.



Fig. 7 - Cleaning Holes

Be sure the component lead is straight and free of solder. Push it gently back through the hole until some of it shows on the other side. Solder carefully but rapidly to prevent chassis damage.

### REPLACING COMPONENTS

3. Components can be replaced with less chance of damage to the chassis than the removal and rewiring of one of the leads. Remove as follows: Clip the leads close to the body of the component. Heat the fillet and gently push the wire through until the hook may be clipped off. Clip the hook off (on the soldered side) with sharp cutters.

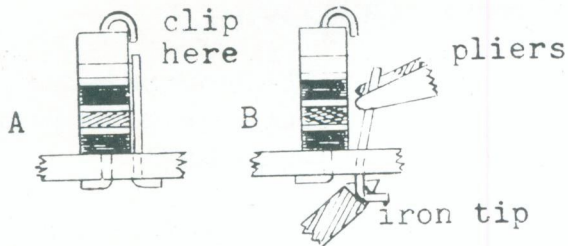

Fig. 9 - Removing Components

With the iron applied to the fillet, pull the wire gently out of the component side of the chassis.

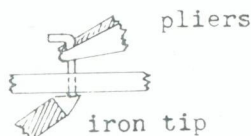

Fig 8 Fig. 8 - Removing Lead

After removing the leads, prepare the chassis for the new component as explained in Fig. 7, paragraph 2.

To replace the component, fold the leads on the new part to the same spacing as the mounting holes. Insert the part and fold the

leads under the chassis to hold the component firmly against it.

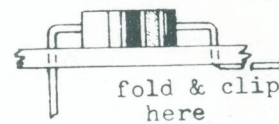

Fig. 10 - Installing New Component

Clip off the excess wire. Place the iron on both the component lead and fillet. Solder carefully and rapidly to prevent damage to the chassis base. If one of the conductors is damaged, it is seldom necessary to scrap the printed chassis. Lay a small piece of wire (#18 to 24 ga.) across the break and solder each end to the conductor.

If a fillet is pulled loose, break it off to get rid of the loose end. Fold the new component lead to lay on the conductor and solder. If the component lead is too short, solder in another piece of wire to bridge the gap. Printed chassis construction places no strain on repairs of this nature, thus, soldering alone will provide sufficient mechanical strength even with heavy shock and vibration in almost every case.

The base material used on the printed chassis is the best available for this service. The two oz. copper is twice as heavy as used in average applications of this type of equipment. This assures reliable service and repair, if and when required. If replacement parts are ordered from the Gates Radio Company, please list the Gates stock number given in the parts list, as well as the description of the part. This will assure receipt of the right part immediately.

### PARTS LIST

<u>Symbol No.</u>	<u>Gates Stock No.</u>	<u>Description</u>
C1	508 0215 000	Cap., .01 uf., 100 V.
C2, C11	522 0178 000	Cap., 25 uf., 6 V. D.C.
C3	522 0160 000	Cap., 100 uf., 3 V. D.C.

<u>Symbol No.</u>	<u>Gates Stock No.</u>	<u>Description</u>
C4, C7, C8		
C10, C13	522 0242 000	Cap., 25 uf., 25 V. D.C.
C5	516 0054 000	Cap., .001 uf., 1 KV
C6	522 0187 000	Cap., 200 uf., 6 V. D.C.
C14	522 0189 000	Cap., 300 uf., 6 V. D.C.
C15	508 0076 000	Cap., .005 uf., 100 V.
C16	506 0005 000	Cap., .1 uf., 200 V. D.C.
P1	610 0243 000	Plug
Q1	380 0004 000	Transistor, 2N422
Q2, Q3, Q4,		
Q5, Q6	380 0014 000	Transistor, 2N1414
Q7	380 0012 000	Transistor, 2N1183
R1	540 0034 000	Res., 240 ohm, 1/2 W., 5%
R2, R4	548 0050 000	Res., 20K ohm, 1/2 W., 1%
R3, R12, R22	540 0062 000	Res., 3600 ohm, 1/2 W., 5%
R5	540 0066 000	Res., 5100 ohm, 1/2 W., 5%
R6	548 0049 000	Res., 100 ohm, 1/2 W., 1%
R7	540 0046 000	Res., 750 ohm, 1/2 W., 5%
R8	540 0077 000	Res., 15K ohm, 1/2 W., 5%
R9	540 0068 000	Res., 6200 ohm, 1/2 W., 5%
R10	540 0064 000	Res., 4300 ohm, 1/2 W., 5%
R11	540 0081 000	Res., 22K ohm, 1/2 W., 5%
R14	540 0086 000	Res., 36K ohm, 1/2 W., 5%
R15	540 0048 000	Res., 910 ohm, 1/2 W., 5%
R16	540 0063 000	Res., 3900 ohm, 1/2 W., 5%
R17	540 0032 000	Res., 200 ohm, 1/2 W., 5%
R18	540 0058 000	Res., 2400 ohm, 1/2 W., 5%
R19	540 0035 000	Res., 270 ohm, 1/2 W., 5%
R20	540 0089 000	Res., 47K ohm, 1/2 W., 5%
R21	540 0073 000	Res., 10K ohm, 1/2 W., 5%
R23	540 0025 000	Res., 100 ohm, 1/2 W., 5%
R24	540 0049 000	Res., 1000 ohm, 1/2 W., 5%
R25	548 0094 000	Res., 28K ohm, 1/2 W., 1%
R26	548 0095 000	Res., 4640 ohm, 1/2 W., 1%
R27	540 0053 000	Res., 1500 ohm, 1/2 W., 5%
R28	540 0084 000	Res., 30K ohm, 1/2 W., 5%
R29	548 0093 000	Res., 61.9 ohm, 1 W., 1%
R30 (M5700A,B)	550 0218 000	Potentiometer, 2500 ohm
R31 (M5700A)	540 0029 000	Res., 150 ohm, 1/2 W., 5%
T1	478 0183 000	Transformer, Input
T2	478 0125 000	Transformer, Output
XQ1, XQ2, XQ3,		
XQ4, XQ5, XQ6	404 0066 000	Socket
XQ7	404 0149 000	Socket

**GATES**

G A T E S R A D I O C O M P A N Y

Subsidiary of Harris-Intertype Corporation  
QUINCY, ILLINOIS

HARRIS  
INTERTYPE  
CORPORATION

INSTALLATION AND OPERATING INSTRUCTIONS  
FOR  
M-6034 TRANSISTOR PREAMPLIFIER

TECHNICAL DATA

GAIN: 45 DB  $\pm$ 1 DB operated into a 600 ohm load

FREQUENCY RESPONSE:  $\pm$ 1 DB, 30 cps to 15,000 cps.

HARMONIC DISTORTION: Under 0.5% from 50 cps to 15 KC at +5 DBM output.  
Under 0.5% from 30 cps to 15 KC at -50 DBM output.

INTERMODULATION DISTORTION: Under 0.5% at -5 DBM output level, and under 1.0% at +5 DBM output level. Distortion measured at equivalent sine wave output using 40 cps and 7 KC mixed 4 to 1.

NOISE LEVEL: -122 DBM equivalent input noise.

SOURCE IMPEDANCE: 30/50 and 150/250 ohms.

INPUT IMPEDANCE: Input transformer unloaded, resulting in input impedance being substantially higher than source impedance.

OUTPUT LOAD IMPEDANCE: 600 ohms  $\pm$ 10%.

MAXIMUM INPUT LEVEL: -40 DBM.

MAXIMUM OUTPUT LEVEL: +5 DBM.

MAXIMUM OPERATING AMBIENT TEMPERATURE: 55° C. (131° F.)

MAXIMUM STORAGE AMBIENT TEMPERATURE: 85° C. (185° F.)

POWER REQUIREMENTS: -30 V. DC at 15 ma with less than .1 MV ripple.

TRANSISTORS: 1 - 2N422                      3 - 2N1414

MOUNTING: Requires M-6039 mounting frame.

SIZE: 3-1/4" Wide X 6-3/8" Long X 1" Thick.

6/28/62

-1- M-6034 Transistor Preamplifier

## DESCRIPTION

The Gates M-6034 Transistor Preamplifier is a premium quality low noise unit for use in consoles, and is completely temperature compensated using the latest techniques. The amplifier has a gain of 45 DB with a maximum output in unbalanced and transformerless, which is designed to operate into a 600 ohm variable attenuator.

The input is balanced, and is connected for 150/250 ohm source impedance at the factory but may be reconnected for 30/50 ohms.

## THEORY OF OPERATION

This amplifier is designed to provide a fixed gain of 45 DB. It is a four-stage amplifier and utilizes a transformerless output. It features negative feedback to reduce distortion to a very low level and minimizes specification changes with transistor changes.

Signal is applied to pins C and E and is fed through transformer, T1, to the base of Q1 (2N422). Q1 is a low noise transistor operated at ideal collector current for minimum noise. It will be noted that the first stage is series fed through T1 to provide the maximum input gain from T1. C1 and R1 are connected across the secondary of T1 to stabilize the amplifier. The value of R1 and C1 were picked to provide a roll off above the audio range to prevent amplification of very high frequency noise.

The signal is then direct coupled from the collector of Q1 to the base of Q2. Q2 is a very high gain stage because the emitter is completely by-passed. The signal is then coupled from the collector of Q2 (thru C8) to Q3. The collector of Q3 is direct coupled to the base of Q4. Q4 is an emitter follower. Emitter followers are very stable and are virtually distortionless. This also provides the low output impedance required to feed a 600 ohm fader. Feedback is applied from R17 through R13 and C9, R7 and C5 to the emitter resistor (R6) of the first stage. R13 and C9 provide a boost of 1 DB at 30 cps to make the response flat in the audio range.

## MAINTENANCE

Transistor amplifiers are designed for a long trouble-free life, however, dust and dirt can cause trouble. A monthly dusting with a soft brush should be adequate.

SHOULD TROUBLE OCCUR -

- Step 1 - First check all DC voltages. The DC voltages determine the bias points of the transistors and any departure of 20% or more should be considered a defect. NOTE: Use of the resistance chart will help detect faulty components.
- Step 2 - Before any signal measurements are made, replace any defective parts to make DC voltages correct.
- Step 3 - After all DC voltages are correct, signal tests may be performed. The correct (RMS) voltages are shown on the schematic diagram. Voltages shown are for -40 DBM input @ 150 ohms not terminated.

DO NOT use an ohmmeter on the printed wiring with transistors in their sockets. Excessive current can flow to damage them.

DO NOT remove or insert transistors with the power ON.

REMEMBER - In transistor circuitry B+ is ground, therefore, capacitors have the positive side connected to ground.

DO NOT probe the printed board with the power ON with a metal screwdriver, etc., that could short out wiring.

RESISTANCE CHART

Resistance Chart taken with Q1, Q2, Q3, Q4 from sockets removed. Remove all transistors before making resistance check.

Measure Resis- tance From	Q1		Q2		Q3		Q4	
	To Gnd	To B-	To Gnd	To B-	To Gnd	To B-	To Gnd	To B-
Base	3200	15K	30K	30K	900	10K	14K	3.5K
Emitter	4700	15K	2.9K	13K	175	10K	2.2K	12K
Collector	30K	30K	15K	9K	14K	3.5K	10K	0

<u>Symbol No.</u>	<u>Gates Stock No.</u>	<u>Description</u>
C1	508 0215 000	Cap., .01 uf, 100 V.
C2	522 0178 000	Cap., 25 uf, 6 V.
C3	522 0160 000	Cap., 100 uf, 3 V.
C4,C7, C8,C10	522 0242 000	Cap., 25 uf, 25 V.
C5	516 0054 000	Cap., .001 uf, 1 KV
C6	522 0187 000	Cap., 200 uf, 6 V.
C9	522 0158 000	Cap., 50 uf, 3 V.
Q1	380 0004 000	Transistor, 2N422
Q2,Q3,Q4	380 0014 000	Transistor, 2N1414
R1	540 0035 000	Res., 270 ohm, 1/2 W, 5%
R2,R4	548 0050 000	Res., 20K ohm, 1/2 W, 1%
R3	540 0062 000	Res., 3600 ohm, 1/2 W, 5%
R5	540 0066 000	Res., 5100 ohm, 1/2 W, 5%
R6	548 0049 000	Res., 100 ohm, 1/2 W, 1%
R7	540 0038 000	Res., 360 ohm, 1/2 W, 5%
R8	540 0077 000	Res., 15K ohm, 1/2 W, 5%
R9	540 0068 000	Res., 6200 ohm, 1/2 W, 5%
R10	540 0064 000	Res., 4300 ohm, 1/2 W, 5%
R11	540 0081 000	Res., 22K ohm, 1/2 W, 5%
R12	540 0062 000	Res., 3600 ohm, 1/2 W, 5%
R13	540 0025 000	Res., 100 ohm, 1/2 W, 5%
R14	540 0086 000	Res., 36K ohm, 1/2 W, 5%
R15	540 0048 000	Res., 910 ohm, 1/2 W, 5%
R16	540 0063 000	Res., 3900 ohm, 1/2 W, 5%
R17	540 0032 000	Res., 200 ohm, 1/2 W, 5%
R18	540 0058 000	Res., 2400 ohm, 1/2 W, 5%
T1	478 0221 000	Transformer, Input
XQ1,XQ2, XQ3,XQ4	404 0066 000	Socket

Schematic - 837 9416 001

TI PRIMARY

IMP.	C.T.	JOIN	CONNECT TO
150Ω	Y&R	YEL. TO RED	BLUE & BRN.
50Ω	R/Y	BLUE TO RED YEL. TO BRN	BLUE & YEL.

GATES RADIO COMPANY QUINCY, ILLINOIS										C-79416 SCALE	
LIST OF PARTS											
QTY.	QTY.	QTY.	QTY.	QTY.	QTY.	ITEM	REFERENCE	PT. OR G.N.	FIN.	DESCRIPTION	MATERIAL

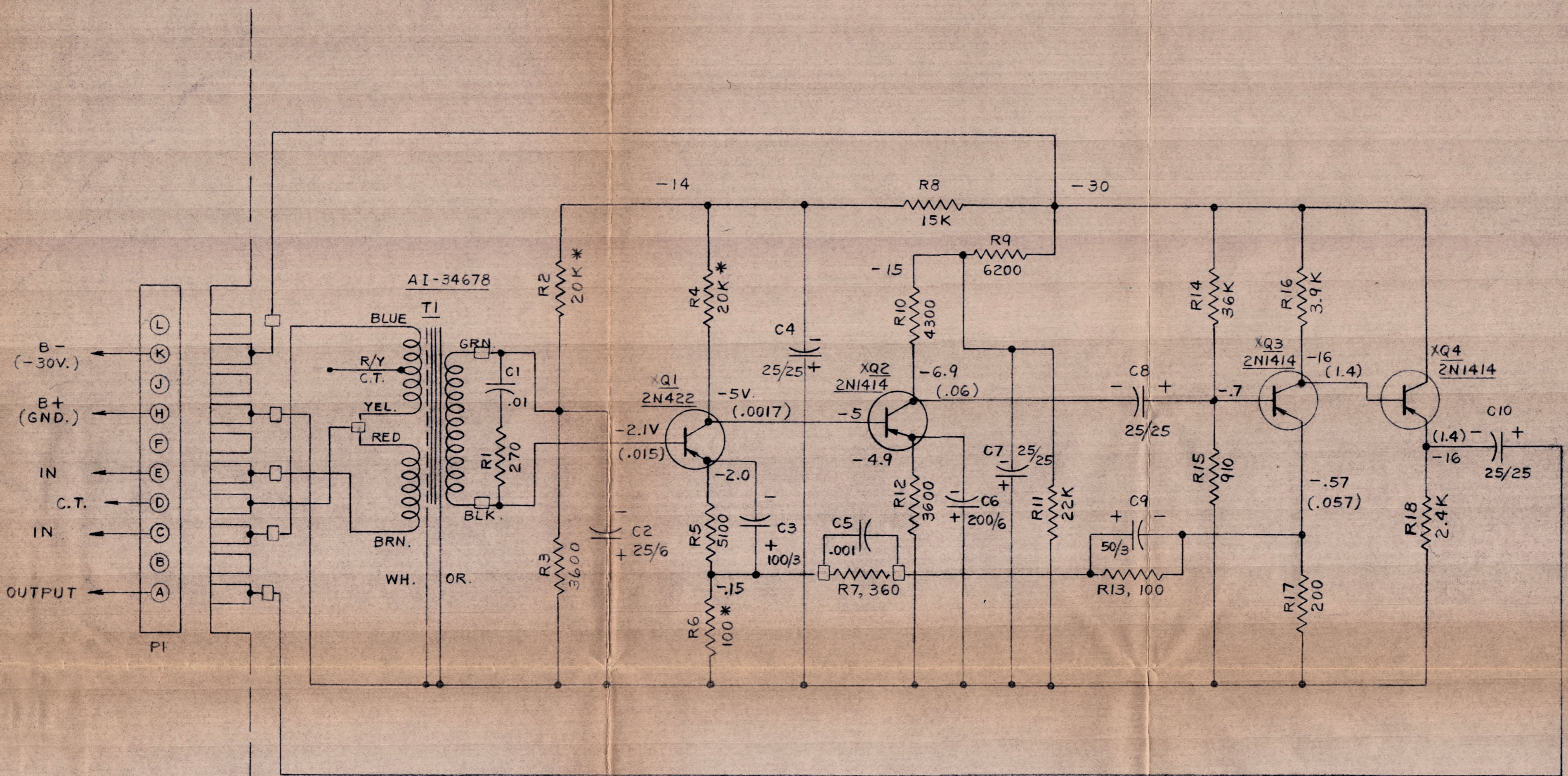

PRINTED BOARD

- 1) DC VOLTAGES ARE TYPICAL AND WERE READ WITH A SIMPSON 260.
- 2) VOLTAGES SHOWN AS (-) ARE SIGNAL VOLTAGES.
- 3) ALL RESISTORS 1/2 WATT, 5% EXCEPT \* 1%
- 4) ALL CAPACITORS IN MFD, WITH D.C.W.V.
- 5) □ INDICATES SOLDER LUG



TITLE SCHEMATIC, CONSOLE PREAMP M6034			
MTL	FIN.	UNLESS OTHERWISE SPECIFIED, ALL TOLERANCES PER GATES SPEC. 05M102	
DR BY D.L.	CH. BY	ENG.	SHEET OF
DATE 11-23-60	CHECKED	RB	C-79416

E.C.N. 8594 7-11-61 165	STATUS	
	DEVELOPMENT	PRODUCTION
	MECH. CHK.	
	PROJ. ENG.	
APPROV. PRODUCTION BY		

INSTALLATION AND OPERATING INSTRUCTIONS

FOR

M-6035 CUE-INTERCOM AMPLIFIER

TECHNICAL DATA

GAIN: 88 DB +2 DB @ 1 KC  
Variable - Requires 10K variable resistor.  
(Part of Console).

FREQUENCY  
RESPONSE: Peaked for maximum intelligibility.

HARMONIC  
DISTORTION: Under 4% at +28 DBM (.6 W) at mid-band  
frequencies.

NOISE: -105 DBM equivalent input noise.

SOURCE  
IMPEDANCE: 45 Ohms.

OUTPUT LOAD  
IMPEDANCE: 45 Ohms. (High Impedance Speaker)

MAXIMUM  
INPUT LEVEL: -35 DBM

MAXIMUM  
OUTPUT LEVEL: +28 DBM

MAXIMUM OPERATING  
AMBIENT TEMPERATURE: 55° C. (131° F.)

MAXIMUM STORAGE  
AMBIENT TEMPERATURE: 85° C. (185° V.)

POWER REQUIREMENTS: -36 V. DC (unregulated) 10 - 75 ma.

TRANSISTORS: 2 - 2N214            2 - 2N1183  
                  3 - 2N1414            1 - 2N1225

SIZE: 3-1/4" Wide X 7-1/2" Long X 1" Thick

DESCRIPTION

The Gates M-6035 Transistor Cue-Intercom Amplifier is designed to be used in transistor consoles for cueing and talkback purposes. The amplifier utilizes a gain control for adjusting to different input levels. The amplifier is designed to be fed from a 45 ohm source and to operate into a 45 ohm speaker or resistive load.

6/26/62

-1-

M-6035 Cue-Intercom  
Amplifier.

The amplifier is designed to be used with the M-6039 mounting frame, which carries a mating receptacle for the printed card type connection. The connections on the printed wiring board are gold flashed for positive connection with the gold contacts on the mating receptacle.

The amplifier requires a -36 V. DC unregulated power source and requires from 10 ma. (at average power output) to a maximum of 75 ma. (at +28 DBM output).

### THEORY OF OPERATION

For the purpose of explanation, the Cue-Intercom Amplifier can be considered to be made up of two distinct parts: the preamplifier, and the power amplifier.

#### THE PREAMPLIFIER

The two stage preamplifier is driven by an input transformer which is somewhat loaded by the input resistor. This resistor prevents excessive signals from being developed by the speaker at its resonance frequency, which would over-drive the input stage. Both stages are of the common emitter configuration, with direct coupling utilized between the stages. On the schematic, 837 9345 001, it should be noted that Q1 is a NPN type transistor and has its emitter returned to B- for biasing purposes.

Biasing is accomplished by a combination of voltage divider and emitter resistance as with R1, R2 and R5. This method of biasing also insures a high degree of temperature stability. Signal degeneration is also for Q2 by R7.

The volume control, (located on the console) situated between the preamplifier and power amplifier, is connected in reverse, to maintain the high source impedance at all settings that the power amplifier requires.

#### THE POWER AMPLIFIER

The output stages of the power amplifier operate Class B, and are arranged in the circuit configuration known as "single ended push-pull", or "followed emitter follower". The upper and lower units are in series across the power supply, and the load is connected at their junction when the signal at the collector of Q4 goes negative Q6 and Q8 conduct, since they are all PNP types. When the signal goes positive Q5 and Q7 conduct since Q5 is a NPN type. Thus, the full signal appears at the junction point.

Note that Q4 is the only stage in the power amplifier with this voltage gain. A high frequency transistor is used at this point

to improve stability. Several feedback loops are employed in this circuit, including R10, C7, C10, and C9, C7 and C10 provide high frequency stability, C12 supplies positive feedback from the output to the collector circuit of Q4 to increase the signal handling capability of this stage.

## MAINTENANCE

### PREVENTIVE MAINTENANCE

The M-6035 Cue-Intercom Amplifier is designed for long, trouble-free service. However, as with all high quality electronic equipment, a regular program of inspection should be followed.

It is recommended that when the amplifier is first received, part of the console, D.C. voltage be measured with the same voltmeter that will be used for maintenance and troubleshooting, and these readings be recorded on the amplifier schematic above the typical voltages shown.

### SERVICING

When servicing the amplifier, the following points should be observed.

1. The condition of the output stage measuring the speaker bus voltage at the junction of R21 and the collector of Q8.
2. Circuit resistances should be measured only after removing the associated transistor or transistors, to prevent damage due to ohmmeter battery voltage.
3. DO NOT remove or insert transistors with the power ON.
4. DO NOT probe the printed board with a metal probe with the power ON.
5. Circuit voltages are reversed from standard vacuum tube practice, as is the polarity of all electrolytic capacitors.
6. The location of the positive end of each electrolytic capacitor is indicated by the white dot marked on the top of the circuit board.

## PARTS LIST

<u>Symbol No.</u>	<u>Gates Stock No.</u>	<u>Description</u>
C1,C2,C3, C4,C9	522 0242 000	Cap., 25 mfd, 25 V.

6/28/62

-3-

M-6035 Cue-Intercom  
Amplifier

<u>Symbol No.</u>	<u>Gates Stock No.</u>	<u>Description</u>
C5	506 0005 000	Cap., .1 mfd., 200 V.
C6	522 0178 000	Cap., 25 mfd., 6 V.
C7,C10	516 0054 000	Cap., .001 mfd., 1 KV, 10%
C8	522 0256 000	Cap., 20 mfd., 50 V.
C11	522 0160 000	Cap., 100 mfd., 3 V
C12	522 0246 000	Cap., 100 mfd., 25 V.
C13	506 0006 000	Cap., .25 mfd., 200 V.
Q1,Q6	380 0011 000	Transistor, 2N214
Q2,Q3,Q5	380 0014 000	Transistor, 2N1414
Q4	380 0013 000	Transistor, 2N1225
Q7,Q8	380 0012 000	Transistor, 2N1183
R1	540 0081 000	Res., 22K ohm, 1/2 W, 5%
R2,R3	540 0071 000	Res., 8200 ohm, 1/2 W, 5%
R4	540 0076 000	Res., 13K ohm, 1/2 W, 5%
R5	540 0075 000	Res., 12K ohm, 1/2 W, 5%
R6	540 0057 000	Res., 2200 ohm, 1/2 W, 5%
R7,R17	540 0025 000	Res., 100 ohm, 1/2 W, 5%
R8	540 0052 000	Res., 1300 ohm, 1/2 W, 5%
R9,R19,R20	540 0041 000	Res., 470 ohm, 1/2 W, 5%
R10,R14	540 0073 000	Res., 10K ohm, 1/2 W, 10%
R11	540 0085 000	Res., 33K ohm, 1/2 W, 5%
R12,R18	540 0039 000	Res., 390 ohm, 1/2 W, 5%
R13	540 0098 000	Res., 110K ohm, 1/2 W, 5%
R15	540 0049 000	Res., 1K ohm, 1/2 W, 5%
R16	540 0070 000	Res., 7500 ohm, 1/2 W, 5%
R21,R22,R23	540 0017 000	Res., 47 ohm, 1/2 W, 5%
R24	540 0023 000	Res., 82 ohm, 1/2 W, 5%
T1	478 0221 000	Transformer, Input
XQ1,XQ2, XQ3,XQ4, XQ5,XQ6	404 0066 000	Socket
XQ7,XQ8	404 0149 000	Socket

Schematic - 837 9345 001

6/28/62

-4-

M-6035 Cue-Intercom  
Amplifier.

106	105	104	103	102	101	GR. NO.	LIST OF PARTS				
QTY.	QTY.	QTY.	QTY.	QTY.	QTY.	ITEM	REFERENCE	PT. OR G.N.	FIN.	DESCRIPTION	MATERIAL

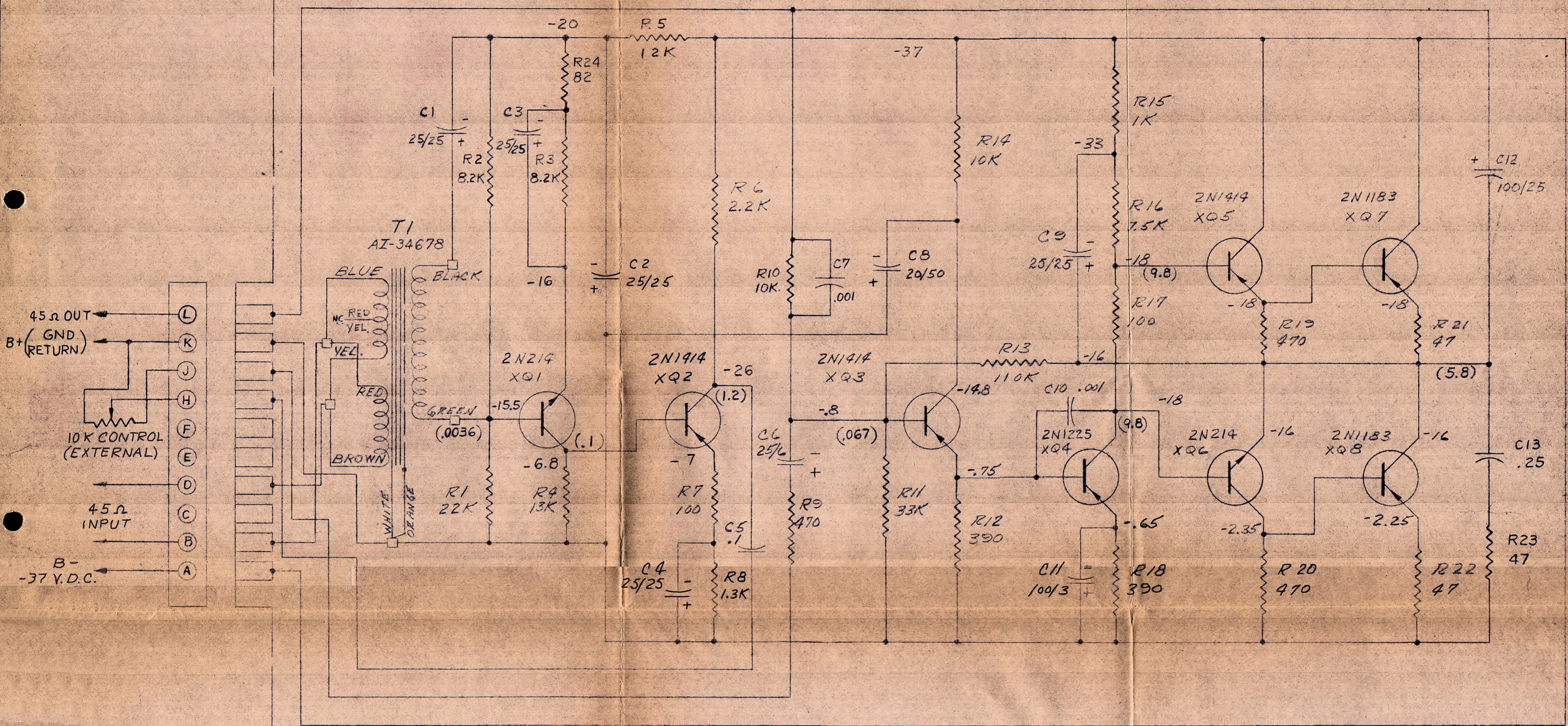

1. ALL CAP. IN MFD., WITH D.C.W.V.
2. ALL RESISTORS 1/2 W. @ 5%.
3. D.C. VOLTAGES MEASURED AGAINST B+ WITH 20KΩ/VOLT METER.
4. ( ) RMS SIGNAL VOLTAGE AT 1KC, -50 DBM IN, +28 DBM OUT.
5. □ INDICATES SOLDER LUG

PRINTED BOARD



TITLE		TRANSISTOR CUE - INTERCOM AMP		M-6035	
SCHEMATIC DIAGRAM					
ECN 8921	2	STATUS		MTL	FIN.
22-62 DL	1	DEVELOPMENT	PRODUCTION	UNLESS OTHERWISE SPECIFIED ALL TOLERANCES PER GATES SPEC 08102	
ECN 875	1	MECH. CHR.		DR. BY JED	CH. BY JED
		PROJ. ENG.		DATE 10-1-60	3-55
		APPROV. PRODUCTION BY		ENG. JED	
SHEET			OF		
			C-79345		

# M6108 TRANSISTOR MONITOR AMPLIFIER

INSTRUCTION BOOK



**GATES**

**GATES RADIO COMPANY**

*A Subsidiary of Harris-Intertype Corporation*

QUINCY, ILLINOIS

## TECHNICAL DATA

### Gain:

53 db (matching 600 ohm).  
39 db min. (bridging 6,000 ohm)

### Frequency Response:

+ 1.0 db from 20 to 20,000 cps  
@ normal output level.

### Harmonic Distortion:

Under 1.0% from 30 to 15,000 cps  
@ + 38 dbm output (6 watts).

Under 1.0% from 50 to 15,000 cps  
@ + 39 dbm output (8 watts).

### Intermodulation Distortion:

Under 1.0% at + 38 dbm equivalent  
sine wave power output, using 40  
and 7000 cps mixed 4:1.

### Noise Level:

- 85 db below rated output level  
(+ 39 dbm).

### Source Impedances:

600 ohms for 600 ohms matching input.  
150/600 for 6000 to 10,000 ohm  
bridging input.

### Input Impedances:

600 ohms matching input, balanced  
(transformer input).  
6,000 ohms, bridging input, balanced  
(bridging pad and transformer input).

### Load Impedances:

4 to 16 ohms (8 ohms nominal), un-  
balanced (transformerless output,  
isolated from AC ground by power  
transformer).

### Output Impedance:

1.2 ohms, approximately.

### Maximum Input Level:

0 dbm.

### Maximum Output Level:

+ 39 into 8 ohms (8 watts).

### Maximum Operating Ambient Temperature:

55° C. (131° F.)

### Maximum Storage Ambient Temperature:

85° C. (185° F.)

### Power Requirements:

117 Volts at 50/60 cps., 18 watts.

### Transistors:

2 - 2N1414	1 - 2N1225
1 - 2N214	2 - 2N1539
2 - 2N1183	

### Rectifiers:

4 - X5A2 (silicon)

### Finish:

Light grey cover, flat black heat  
sink chassis.

### Mounting:

Two keyhole slots, rubber bumpers on  
bottom, permanent or movable mounting  
in any position.

### Size:

3-1/4" high, 4-3/8" deep, 8-1/2" long.

### Weight:

4 lbs., net.                      7 lbs., packed.

### Cubage:

0.9 cu. ft., domestic pack.

## DESCRIPTION

The M6108 Monitor Amplifier is a trans-  
istorized, self-contained amplifier de-  
signed for use in broadcasting, record-  
ing, and general sound reinforcement  
applications. Special techniques have  
been employed to obtain reliability,

low distortion, and good temperature sta-  
bility. The amplifier can be mounted in  
any position and does not require ventil-  
ation when handling 8 watts of program  
material. The input, power, output con-  
nections, fuse and input level control  
are mounted on end panels of the chassis.

## INSTALLATION

### MOUNTING

The amplifier has been provided with two keyhole slots for #8 screws for fixed or permanent mounting.

### INPUT CONNECTIONS

Provisions are made for changing from 600 ohm matching to 6,000 ohm bridging on the input terminal strip. Fig. 1 shows the connection for 600 ohms.

Fig. 2 shows the connection for 6,000 ohm bridging.

In the event that a preamplifier driver is used requiring a minimum load of 10,000 ohms, a 2200 ohm resistor may be added at each bridging input terminal. With this change, 1.5 volts input will be required for full output.

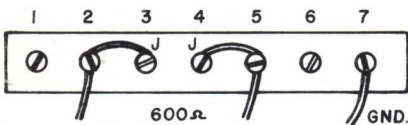

Fig. 1

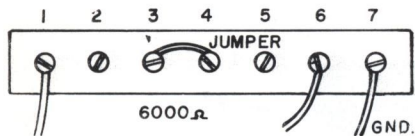

Fig. 2

### OUTPUT CONNECTIONS

Output connections are made to the two lug terminal strip on the end plate of the chassis. Groups of speakers may be driven with this amplifier; connected in series, parallel, or series parallel; but the combined impedance should not be less than 4 ohms. With an impedance of more than 12 ohms, the amplifier will not be able to deliver full output power. Speaker matching transformers permit the paralleling of a number of speakers, depending on the unit required. Gates Part No. 813 0601 001 transformer is available, having a primary of 48 ohms and a secondary of 8 ohms for matching purposes.

In wiring speaker loads it should be remembered that 8 watts at 8 ohms represents 1 ampere of audio current. The recommended use of No. 16 gauge twisted and shielded wire will prevent power losses and possible interaction of circuits.

### AMPLIFIER PARALLELING

It is not recommended that amplifiers of this type be paralleled at their outputs to obtain higher power. Where more power is required than can be supplied by one amplifier, the speaker load should be divided between several amplifiers which have their inputs bridged across the common signal source.

### POWER CONNECTIONS

117 volts A.C., 50/60 cycles is supplied thru the power cord and power plug on the chassis end plate. A power switch is not required due to the low power consumption and heat dissipation.

### NOTE

While the amplifier can handle a continuous 8 watts of program material, CAUTION should be exercised during full power sine wave testing to avoid exceeding the thermal capabilities of the chassis heat sink. During these tests it is recommended that a duty cycle of 30 seconds on to 3 minutes off be used to allow heat build-up to dissipate.



M6108 MONITOR AMPLIFIER

## THEORY OF OPERATION

The amplifier is driven by an input transformer which provides for isolation and matching functions in the primary by means of split windings and resistive pads. The input level control provides a constant load to the input transformer secondary while furnishing a gain control function. Transistor Q1 operates as an emitter follower and provides impedance matching from the input to the voltage amplifier, Q2. Note that Q2 is the only stage which has voltage gain. A high frequency transistor is used at this point to improve stability. The output stages of the amplifier operate Class B, and are arranged in the circuit configuration known as "single ended push-pull" or a "followed emitter follower". The upper and lower units are in series across the power supply, and the load is connected at their junction. When the signal at the collector of Q2 goes negative; Q3, Q5, and Q7 conduct; since they are all PNP types. When the

signal goes positive; Q4, Q6, and Q8 all conduct; since Q4 is an NPN type. Thus, the full signal appears at the junction point. Q3, Q5, Q7, and Q6, Q8 are connected in a compound or "Darlington" configuration, a connection which provides extremely high current gain, and improves linearity at high signal levels.

General feedback loops are employed in the amplifier including R3, R19, C2, C4, and C5. C2 and C4 provide high frequency feedback while C5 supplies positive feedback from the output to the collector circuit of Q2 to increase the signal handling capacity of this stage.

Thermistor R4 compensates for variations in the amplifier bias due to temperature changes. Choke L1 renders the amplifier insensitive to changes in capacity across the output leads. The power supply is a conventional full wave bridge rectifier with filter capacitor circuit.

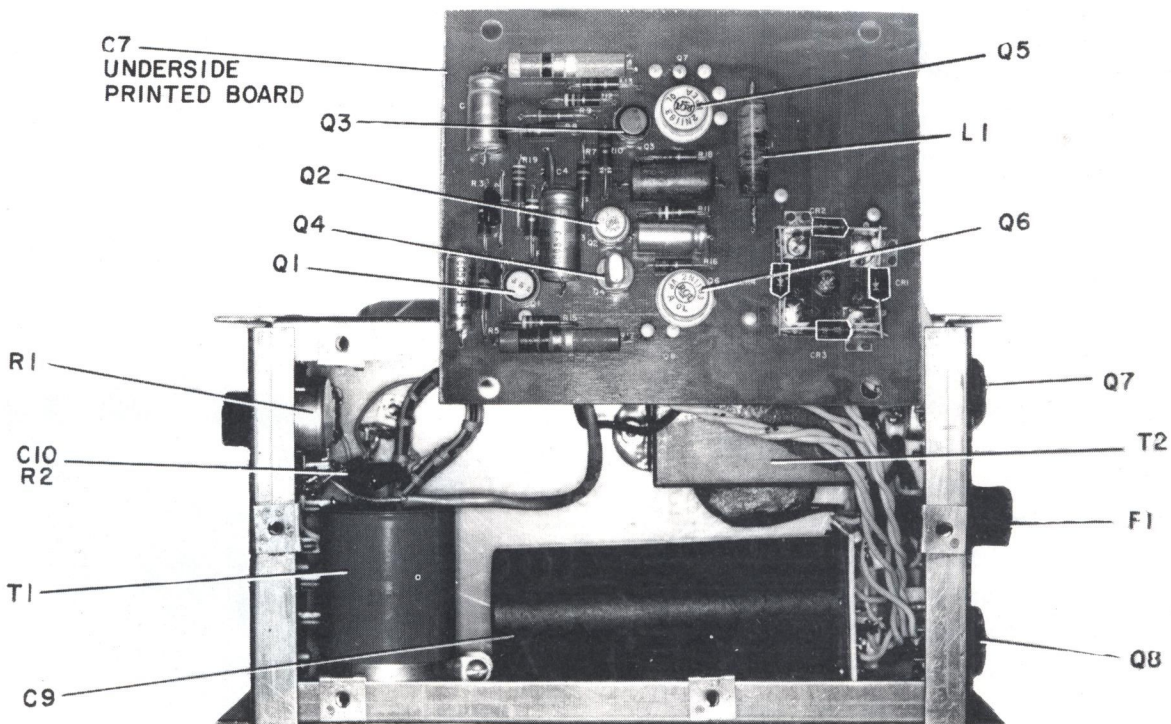

**PARTS LOCATION  
M6108 TRANSISTOR  
MONITOR AMPLIFIER**

T1 PRIMARY CONNECTIONS

PRI. IMP.	JUMPER	CONNECT TO
600Ω	2 TO 3 4 TO 5	2 5
6000Ω	3 TO 4	1 6

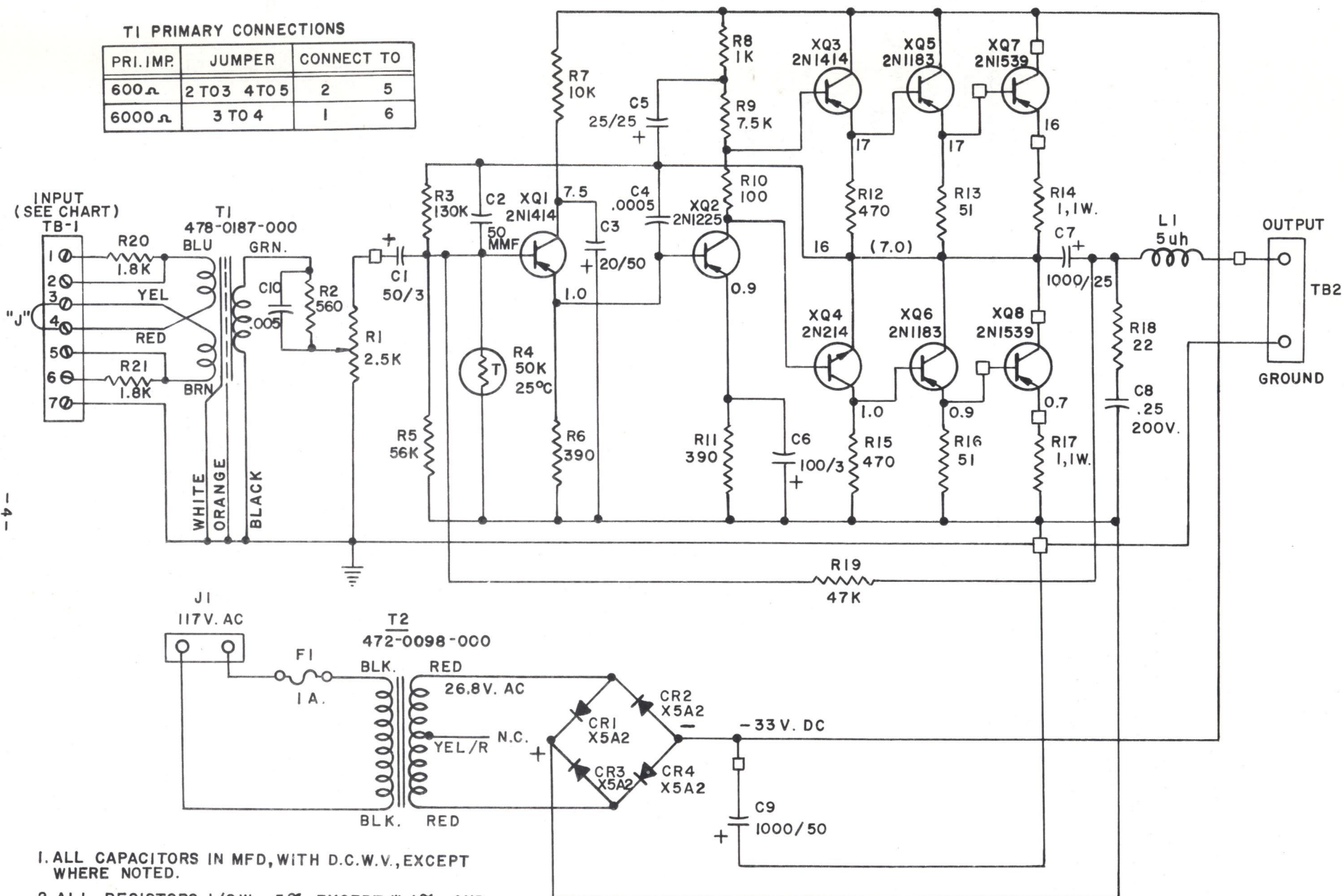

1. ALL CAPACITORS IN MFD, WITH D.C.W.V., EXCEPT WHERE NOTED.
2. ALL RESISTORS 1/2W., 5% EXCEPT \* 1%, AND WHERE NOTED.
3. □ DESIGNATES BOARD LUG CONNECTIONS.
4. D.C. VOLTAGES MEASURED AGAINST B+, WITH 20KΩ VOLT METER, AT +38 DBM OUTPUT.
5. ( ) R.M.S. SIGNAL VOLTAGES AT 1KC, -15 DBM INPUT, (600Ω) +38 DBM OUTPUT.



SCHMATIC  
M6108 TRANSISTOR  
MONITOR AMPLIFIER  
6-19-61 813 6261 001

## MAINTENANCE

### PREVENTIVE MAINTENANCE

The M6801 Monitor Amplifier is designed for long, trouble-free service. However, as with all high quality electronic equipment, a regular program of inspection should be followed. These points should be covered:

1. Check the power amplifier supply voltage at the collector of Q5 or Q7. On the power transistors, such as the 2N1183 and 2N1539, the collector is connected to the case.
2. Check the speaker bus voltage, which appears at the collectors, or cases of Q6 and Q8.
3. Remove dust which collects on the printed board or in the housing, with a soft brush.

It is recommended that when the amplifier is first placed in operation, that D.C. voltages be measured with the same voltmeter that will be used for maintenance and troubleshooting, and that these readings be recorded on the amplifier schematic. The speaker bus and B- voltages should be recorded with an without signal.

### SERVICING

When servicing the amplifier, the following points should be observed:

1. The condition of the power supply can be most readily checked by measuring

the D.C. voltage between the chassis and the case of output transistor Q8. (One of the two power transistors mounted on the end of the chassis). This voltage will be much higher or lower than normal if trouble is present in the power amplifier.

2. Voltages may be checked with Q5, Q6, Q7 and Q8 removed, provided that the speaker load is disconnected.
3. Circuit resistances should be measured only after removing the associated transistor or transistors, to prevent damage due to ohm-meter battery voltage.
4. Do not remove or insert transistors with the power on.
5. Do not probe the printed board with a metal probe with the power on.
6. Circuit voltages are reversed from standard vacuum tube practice, as is the polarity of all electrolytic capacitors.
7. The location of the positive end of each electrolytic capacitor is indicated by the white dot marked on top of the circuit board.
8. When replacing either Q7 or Q8, and before turning on the power, check with an ohm-meter between transistor case and chassis to make certain that a short circuit does not exist. Note that insulating washers are placed under the transistors to provide insulation.

### PRINTED CHASSIS COMPONENT REPLACEMENT

#### 1. CHECKING COMPONENTS

The components should be carefully checked by measuring circuit voltages and resistances before attempting to remove one of the leads from the printed chassis. Extreme care must be exercised in removing the lead to prevent damage to the board or conductors. This operation

should not be considered unless it is the only way the component can be checked.

If one lead must be removed without damage to the component, apply a well cleaned and tinned 25 to 60 watt iron to the fillet adjacent to the lead. With small long nose pliers or thin screwdriver, pry the folded portion of the lead in line

with the hole. Applying the iron for more than four seconds at a time may damage the chassis base material.

Remove as much solder from the lead as possible. Remove all the kinks in the wire. With heat applied, gently pull the wire through the hole.

### 2. RESOLDERING THE COMPONENT LEAD

If the component is good, replace as follows: Use a metal twist drill (1/8" dia. or less) to clear the hole only in the fillet of solder. Turn with the fingers only. Remove solder slowly to prevent the drill from tearing the fillet.

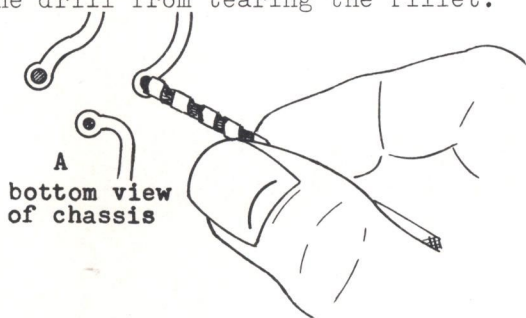

Fig. 3 - Cleaning Holes

With the iron applied to the fillet, pull the wire gently out of the component side of the chassis:

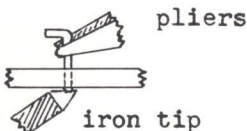

Fig. 4 - Removing Lead

Be sure the component lead is straight and free of solder. Push it gently back thru the hole until some of it shows on the other side. Solder carefully but rapidly to prevent chassis damage.

### 3. REPLACING COMPONENTS

Components can be replaced with less chance of damage to the chassis than the removal and rewiring of one of the leads. Remove as follows: Clip the leads close to the body of the component. Heat the fillet and gently push the wire thru until the hook may be clipped off. Clip the hook off (on the soldered side) with

sharp cutters.

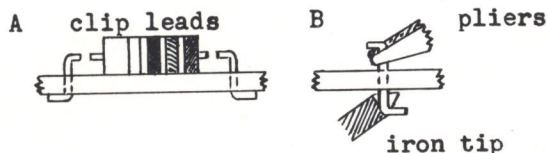

Fig. 5 - Removing Components

After removing the leads, prepare the chassis for the new component as explained in paragraph 2 and Fig. 3.

To replace the component, fold the leads on the new part to the same spacing as the mounting holes. Insert the part and fold the leads under the chassis to hold the component firmly against it:

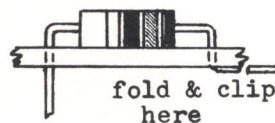

Fig. 6 - Installing New Component

Clip off the excess wire. Place the iron on both the component lead and fillet. Solder carefully and rapidly to prevent damage to the chassis base. If one of the conductors is damaged, it is seldom necessary to scrap the printed chassis. Lay a small piece of wire (#18 to 24 ga.) across the break and solder each end to the conductor.

If the fillet is pulled loose, break it off to get rid of the loose end. Fold the new component lead to lay on the conductor and solder. If the component lead is too short, solder in another piece of wire to bridge the gap. Printed chassis construction places no mechanical strain on repairs of this nature, thus, soldering alone will provide sufficient mechanical strength even with heavy shock and vibration in almost every case.

The base material used on the printed chassis is the best available for this service. The two ounce copper is twice as heavy as used in average applications of this type of equipment. This assures reliable service and repair.

PARTS LIST

<u>Symbol No.</u>	<u>Gates Part No.</u>	<u>Description</u>
C1	522 0158 000	Cap., 50 ufd., 3 V.
C2	502 0200 000	Cap., 50 uufd., 500 V.
C3	522 0256 000	Cap., 20 ufd., 50 V.
C4	516 0045 000	Cap., .0005 uf., 1 KV., $\pm$ 10%.
C5	522 0242 000	Cap., 25 ufd., 25 V.
C6	522 0160 000	Cap., 100 ufd., 3 V.
C7	522 0306 000	Cap., 1000 ufd., 25 V.
C8	506 0006 000	Cap., .25 ufd., 200 V.
C9	524 0100 000	Cap., 1000 ufd., 50 V.
C10	508 <del>0208</del> 000 0076	Cap., .005 ufd., 100 V.
CR1,CR2, CR3,CR4	384 0062 000	Silicon Rectifier
F1	398 0054 000	Fuse, 1 amp., 250 V.
L1	494 0135 000	Choke, RF, 5 uh
Q1,Q3	380 0014 000	Transistor, 2N1414
Q2	380 0013 000	Transistor, 2N1225
Q4	380 0011 000	Transistor, 2N214
Q5,Q6	380 0012 000	Transistor, 2N1183
Q7,Q8	380 0016 000	Transistor, 2N1539
R1	550 0218 000	Potentiometer, 2500 Ohm
R2	540 0043 000	Res., 560 Ohm, 1/2 W., 5%
R3	540 0100 000	Res., 130K Ohm, 1/2 W., 5%
R4	559 0002 000	Thermistor, 50K Ohm
R5	540 0091 000	Res., 56K Ohm, 1/2 W., 5%
R6	540 0039 000	Res., 390 Ohm, 1/2 W., 5%
R7	540 0073 000	Res., 10K Ohm, 1/2 W., 5%
R8	540 0049 000	Res., 1K Ohm, 1/2 W., 5%
R9	540 <del>0142</del> 000 8076	Res., 7.5K Ohm, 1/2 W., 5%
R10	540 0024 000	Res., 100 Ohm, 1/2 W., 5%
R11	540 0039 000	Res., 390 Ohm, 1/2 W., 5%
R12,R15	540 0041 000	Res., 470 Ohm, 1/2 W., 5%
R13,R16	540 0018 000	Res., 51 Ohm, 1/2 W., 5%
R14,R17	542 0703 000	Res., 1 Ohm, 1 W., 5%
R18	540 0009 000	Res., 22 Ohm, 1/2 W., 5%
R19	540 0089 000	Res., 47K Ohm, 1/2 W., 5%
R20,R21	540 0055 000	Res., 1.8K Ohm, 1/2 W., 5%
T1	478 0187 000	Transformer, Input
T2	472 0098 000	Transformer, Power
TB1	614 0218 000	Terminal Strip, 7 terminal
TB2	614 0213 000	Terminal Strip, 2 terminal
XQ1,XQ2, XQ3,XQ4	404 0066 000	Socket
XQ7,XQ8	404 0136 000	Socket

MODIFICATION OF THE GATES'

M-6108 TRANSISTOR MONITOR AMPLIFIER

FOR CURRENT LIMITING.

If the output of the M-6108 Monitor Amplifier should be accidentally shorted, or if oscillation in the amplifier should develop, excess current flow through the output stage could damage the 2N1539 output transistors or the emitter resistors in this stage.

A current limiting device has been incorporated in the amplifier to limit the output stage current under such conditions to a safe level, thus preventing damage to the amplifier. This device in no way affects the normal operation of the amplifier.

Refer to drawing 813 6261 001, the schematic of the monitor amplifier and drawing 813 7719 001, the schematic of the current limiter for a better understanding of the operation of this circuit. Transistors XQ9 and XQ10 are connected as a direct coupled amplifier and act to amplify the voltage drop across R17, the emitter resistance for XQ8, one of the output transistors. When the voltage drop across this resistor exceeds a certain predetermined level, (due to excess current flow in the output stage) XQ11 becomes saturated since its base is direct coupled to the collector of XQ10 of the voltage sensing amplifier. The collector of XQ11 is connected to the collector of XQ2. When XQ11 reaches saturation, the effective impedance between collector and emitter becomes very low. Therefore, the collector of XQ2 is effectively grounded through R26. This action pulls the center bus of the single-ended push-pull output stage down, limiting the output stage current to a safe value.

It should be remembered that a full 8 watts of program material can be handled safely by the amplifier. If this limit is exceeded, program peaks will cause the amplifier to go into current limiting as explained above. This is not a fault of the amplifier but simply a result of the current limiting device performing properly.

6/28/62

-1-

Modifications of  
M-6108 Monitor  
Amplifier

104	103	102	101	FIRST MADE FOR
QTY.	QTY.	QTY.	QTY.	GR. NO.

LIST OF PARTS

REFERENCE	PT. OR G.N.	FIN.	DESCRIPTION	MATL.
-----------	-------------	------	-------------	-------

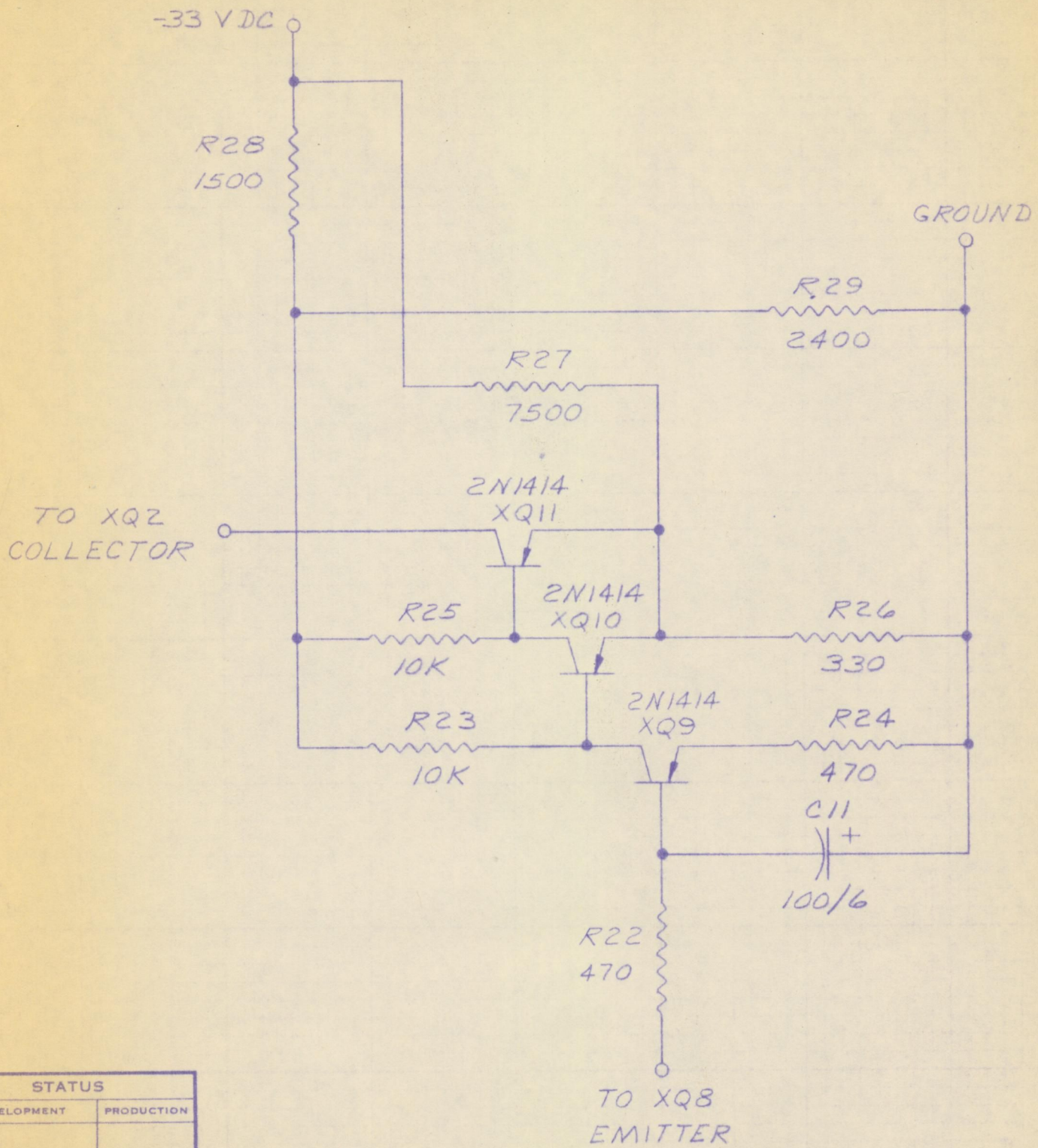

STATUS	
DEVELOPMENT	PRODUCTION
MECH. CHK.	
PROJ. ENG.	
PROV. INSTRUCTION BY	

www.SteamPoweredRadio.com

CH. BY <i>JL</i>	MTL.
DATE 6-29-62	
DR. BY <i>JM</i>	ENG. <i>JL</i>
DATE 6-29-62	FIN.

TITLE SCHEMATIC - CURRENT LIMITER  
TRANSISTOR MONITOR AMP.  
M-6108

UNLESS OTHERWISE SPECIFIED,  
ALL TOLERANCES PER GATES  
SPEC GSM102.  
813-7719-001



# GATES RADIO COMPANY

A Subsidiary of Harris-Intertype Corporation

QUINCY, ILLINOIS, 62302  
Tel. (Area Code 217) 222-8202

CONTRACT  
NO. LD-10165

## PROPOSAL AND ACCEPTANCE

FOR

\_\_\_\_\_ Radio Station KPDQ \_\_\_\_\_  
\_\_\_\_\_ 4903 N.E. Sandy Blvd. \_\_\_\_\_  
\_\_\_\_\_ Portland, Oregon 97213 \_\_\_\_\_  
\_\_\_\_\_  
\_\_\_\_\_

We are pleased to present this Proposal to supply the apparatus as itemized and priced in the attached schedule for your consideration and acceptance.

GATES RADIO COMPANY

Prepared by:

\_\_\_\_\_ Lewis J. Denes \_\_\_\_\_  
Name

\_\_\_\_\_ Sales Engineer \_\_\_\_\_  
Title

\_\_\_\_\_ *Lewis J. Denes* \_\_\_\_\_  
Signature

\_\_\_\_\_ <sup>oct.</sup> November 1, 1965 \_\_\_\_\_  
Date

Salesman Number 31 State Number \_\_\_\_\_



**GATES RADIO COMPANY**

A Subsidiary of Harris-Intertype Corporation

QUINCY, ILLINOIS, 62302  
Tel. (Area Code 217) 222-8202

**EQUIPMENT**

ITEM NO.	QTY.	STOCK NO.	DESCRIPTION	UNIT PRICE	TOTAL
<b>"STUDIO EQUIPMENT"</b>					
1	1	994-6158-001	<u>EXECUTIVE</u> , M-6158 ten channel stereo audio console.		3,995.00
2	1	994-5700-002	M-5700A, third prog. amp. for Executive.		150.00
3	2	994-6424-001	Deluxe intercom sub-station.	32.50	65.00
4	3	994-6143-002	M-6143A, stereo turntable assembly, complete.	558.00	1,674.00
5	2	994-6213-010	M-6213I, record/play unit, mono.	995.00	1,990.00
6	2	994-6211-007	M-6211F, playback unit, mono.	580.00	1,160.00
7	1	994-6219-001	M-6219, automatic switcher, mono.		139.50
8	1	994-6221-001	M-6221, remote control unit.		36.00
9	42	723-0045-000	A-300A, 40 sec. Fidelipac.	2.25	94.50
10	72	732-0046-000	A-300B, 70 sec. Fidelipac.	2.35	169.20
11	20	732-0049-000	A-300E, 5½ min. Fidelipac.	3.00	60.00
12	2	994-5986-001	M-5986, cartridge storage rack.	37.50	75.00
13	3		<u>MAGNECORD</u> , 1022RX (Relay Control) provision for full remote control. NOTE: This unit to be 3-3/4 - 7-1/2 IPS.	998.00	2,994.00
14	3	730-0831-000	Remote control box, Model A91E6786-2.	58.00	174.00
15	1	730-0425-000	A81D128-A, Transport case.		30.00
16	1	730-426 -000	A81D129-1, Electronics case.		30.00
17	1	720-0016-000	EV 666 microphone.		153.00
			<b>TOTAL: Studio Equipment \$ <u>12,989.20</u></b>		



**SHIPMENT AND PAYMENT ARRANGEMENTS**

1. Estimated time(s) of shipment:

ITEM NUMBER

ESTIMATED SHIPMENT DATE

2. Summary of items and payment arrangements:

Transmitting Equipment .....	\$	_____
Monitoring Equipment .....	\$	_____
Phasing Equipment & Accessories .....	\$	_____
Tuning Unit, Transmission Line .....	\$	_____
Antenna Equipment & Accessories .....	\$	_____
Studio Equipment .....	\$	<b>12,989.20</b>
Remote Control Equipment .....	\$	_____
<hr/>		
Total Equipment .....	\$	<b>12,989.20</b>
<hr/>		
EQUIPMENT PRICE .....	\$	<b>12,989.20</b>
Tax (description) .....	\$	_____
Total, including tax .....	\$	_____
Trade in allowance on .....	\$	_____
Total Price, less trade in .....	\$	<b>12,500.00</b>
Payable as follows: .....	\$	_____
Cash with order .....	\$	<b>1,000.00</b>
<hr/>		
Cash due upon receipt of construction permit .....	\$	_____
Balance due <b>Deferred payments, see below.</b>	\$	<b>11,500.00</b>

**1st. payment due Dec. 26, 1965**

If the above provides for payment in deferred installments, purchaser authorizes seller, in acknowledging this order, to calculate and state in its acknowledgement, the balance remaining unpaid to seller under this contract, the total amount of the finance charge payable on said balance, computed at 4 1/2 % per annum, the time balance inclusive of finance charge payable by purchaser, and the amount of each of the 24 substantially equal and consecutive monthly installments, the first of which installments will be due \_\_\_\_\_ month (s) after the anticipated date of shipment if the major item of equipment described herein, as determined by seller. All instruments on deferred transactions shall be executed prior to shipment.

ALL PRICES ARE NET, ARE F.O.B. QUINCY, ILLINOIS, ON EQUIPMENT MANUFACTURED BY SELLER AND F.O.B. SHIPPING POINT(S) OTHERWISE, AND ARE SUBJECT TO ADJUSTMENT AS HEREIN PROVIDED.

THE PROVISIONS OF THE REVERSE SIDE HEREOF ARE A PART OF THIS ORDER, AND UPON ACCEPTANCE OF THIS ORDER SHALL BE BINDING UPON SELLER AND PURCHASER.

This proposal and acceptance consisting of pages numbered 1 to 4, inclusive, is hereby accepted this 5th day of October, 19 65

**Payments will be made through bank draft, U.S. National Bank, Hollywood Branch, similar to their present contract.**

\_\_\_\_\_  
 (Purchaser's name, corporation or partnership)

\_\_\_\_\_  
 (Signature of owner, partner or officer -- state which)

