

# TECHNICAL MANUAL

SYSTEM SWITCHING CENTER  
AND  
NINE-SOURCE EXTENDER

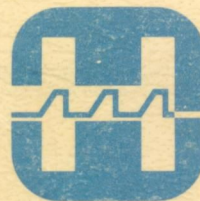

**HARRIS**  
COMMUNICATIONS AND  
INFORMATION HANDLING

## WARRANTY

Seller warrants new equipment manufactured by Harris Corporation, Gates Broadcast Equipment Division against defects in material or workmanship at the time for delivery thereof, that develop under normal use within a period of one year (6 months on moving parts) from the date of shipment, of which Purchaser gives Seller prompt written notice. Other manufacturers' equipment, if any, including electron tubes, and towers shall carry only such manufacturers' standard warranty.

Seller's sole responsibility for any breach of the foregoing provision of this contract, with respect to any equipment or parts not conforming to the warranty or the description herein contained, is at its option, (a) to repair or replace such equipment or parts upon the return thereof f.o.b. Seller's factory within the period aforesaid, or (b) to accept the return thereof f.o.b. Purchaser's point of installation, whereupon Seller shall either (1) issue a credit to Purchaser's account hereunder in an amount equal to an equitable portion of the total contract price, without interest, or (2) if the total contract price has been paid, refund to Purchaser an equitable portion thereof, without interest.

If the Equipment is described as used, it is sold as is and where is. If the contract covers equipment not owned by Seller at this date it is sold subject to Seller's acquisition of possession and title.

Seller assumes no responsibility for design characteristics of special equipment manufactured to specifications supplied by or on behalf of Purchaser.

Seller shall not be liable for any expense whether for repairs, replacements, material, service or otherwise, incurred by Purchaser or modifications made by Purchaser to the Equipment without prior written consent of Seller.

EXCEPT AS SET FORTH HEREIN, AND EXCEPT AS TO TITLE, THERE ARE NO WARRANTIES, OR ANY AFFIRMATIONS OF FACT OR PROMISES BY SELLER, WITH REFERENCE TO THE EQUIPMENT, OR TO MERCHANTABILITY, INFRINGEMENT, OR OTHERWISE, WHICH EXTEND BEYOND THE DESCRIPTION OF THE EQUIPMENT ON THE FACE HEREOF.

## RETURNS AND EXCHANGES

Do not return any merchandise without our written approval and Return Authorization. We will provide special shipping instructions and a code number that will assure proper handling and prompt issuance of credit. Please furnish complete details as to circumstances and reasons when requesting return of merchandise. Custom built equipment or merchandise specially ordered for you is not returnable. Where return is at the request of, or for the convenience of the customer, a restocking fee of 15% will be charged. All returned merchandise must be sent freight prepaid and properly insured by the customer. When writing to Harris Corporation, Gates Broadcast Equipment Division about your order, it will be helpful if you specify the Harris/Gates Factory Order Number or Invoice Number.

## WARRANTY ADJUSTMENTS

In the event of equipment failure during the warranty period, replacement or repair parts may be provided in accordance with the provisions of the Harris/Gates Warranty. In most cases you will be required to return the defective merchandise or part to Harris/Gates f.o.b. Quincy, Illinois for replacement or repair. Cost of repair parts or replacement merchandise will be billed to your account at the time of shipment and compensating credit will be issued to offset the charge when the defective items are returned.

## MODIFICATIONS

Harris/Gates reserves the right to modify the design and specifications of the equipment shown in this manual without notice or to withdraw any item from sale provided, however, that any modification shall not adversely affect the performance of the equipment so modified.

## DAMAGES AND RISK OF LOSS

Purchaser assumes all responsibility for and risk of loss of, or damage to, the Equipment upon delivery at Seller's shipping point, notwithstanding the fact that Seller may have selected the carrier.

In no event shall Seller be liable under any provision of this contract for loss of business or of anticipated profits by Purchaser, outlays by Purchaser in anticipation of business, other incidental or consequential damages on account of negligence.

Purchaser agrees to indemnify Seller against all claims, whether on account of negligence or otherwise, except those asserted by Seller's employees, arising out of or resulting from the erection, operation or use of the Equipment.

SYSTEM SWITCHING CENTER  
AND  
NINE-SOURCE EXTENDER



888 1143 001

Price: \$25.00

GATES RADIO COMPANY  
QUINCY, ILLINOIS

If You Didn't Get This From My Site,  
Then It Was Stolen From  
[www.SteamPoweredRadio.com](http://www.SteamPoweredRadio.com)

1143

## SAFETY NOTICE

WARNING: THE CURRENTS AND VOLTAGES IN THIS EQUIPMENT ARE DANGEROUS AND UNDER CERTAIN CONDITIONS, COULD BE FATAL.

This Manual is intended as general guidance for trained and qualified installation, operating, maintenance and service personnel who are familiar with and aware of the dangers inherent to handling potentially hazardous electrical and/or electronic circuits. It is not intended to contain a complete statement of all safety precautions which should be observed by personnel in using this or other electronic equipment.

THE INSTALLATION, OPERATION, MAINTENANCE AND SERVICING OF THIS EQUIPMENT INVOLVES RISKS TO BOTH PERSONNEL AND EQUIPMENT, AND MUST BE PERFORMED ONLY BY PROPERLY TRAINED AND EXPERIENCED PERSONNEL EXERCISING DUE CARE. PERSONNEL MUST FAMILIARIZE THEMSELVES WITH SAFETY REQUIREMENTS, SAFE HANDLING AND OPERATING PRACTICE, AND RELATED FIRST-AID PROCEDURES (E.G., FOR ELECTRICAL BURNS AND ELECTRICAL SHOCK).

Gates shall not be responsible for injury or damage resulting from improper installation, operation, maintenance or servicing, or from the use of improperly trained or inexperienced personnel in the performance of such tasks, or from the failure of persons engaged in such tasks to exercise due care.

As with all electronic equipment, care should be taken to avoid electrical shock in all circuits where substantial currents or voltages may be present, either thru design or short circuit. Caution should also be observed in lifting and hoisting equipment, especially regarding large structures, during installation.

## LIABILITY LIMITATION

The procedures outlined in this Manual are based on the information available at the time of publication and should permit the specified use with minimum risk. However, the manufacturer cannot assume liability with respect to technical application of the contents and shall, under no circumstances, be responsible for damage or injury (whether to person or property) resulting from its use.

The manufacturer is specifically not liable for any damage or injury arising out of failure to follow the instructions in this Manual or failure to exercise due care and caution during installation, operation, maintenance and service of this equipment.

## CAUTIONARY NOTICE

Always disconnect power before opening covers, doors, enclosures, gates, panels or shields. Always use grounding sticks and short out high voltage points before servicing. Never make internal adjustments, perform maintenance or service when alone or when tired.

Never remove, short-circuit or tamper with interlock switches on access covers, doors, enclosures, gates, panels or shields. Keep away from live circuits, know your equipment and don't take chances. Proper training of experienced personnel and observing the above guidelines will help assure safe and continued operation of this equipment.

SYSTEM SWITCHING CENTER  
AND  
NINE-SOURCE EXTENDER

TECHNICAL MANUAL 888-1143-001

SYSTEM SWITCHING CENTER	994-6880
NINE-SOURCE EXTENDER	994-6881
CHANNEL MODULE	994-6882-002
BOOSTER AMPLIFIER	994-6883
ALARM CIRCUIT CARD	994-6884
KEYSET	994-6885
GENERAL DESCRIPTION	SECTION 1.0
INSTALLATION	SECTION 2.0
OPERATION	SECTION 3.0
CIRCUIT DESCRIPTION	SECTION 4.0
PARTS LISTS	SECTION 5.0
SCHEMATIC DIAGRAMS	SECTION 6.0

1143

## SYSTEM SWITCHING CENTER

### 1.0 GENERAL DESCRIPTION

#### 1.1 GENERAL

1.1.1 The System Switching Center (SSC) is a central processing unit for radio automation systems. It contains power supplies, logic circuits, digital displays for SOURCE PRESET (next to run) and PROGRAM OUTPUT (source on air), system function controls (START, STOP, RUN, HOLD) and an AUDITION SELECTOR. Each source (numbered 1 thru 0) is served by its own plug-in Channel Module.

1.1.2 When more than ten sources are required in an automation system, a companion Nine Source Extender may be connected to the System Switching Center. This Extender (SSCX) accommodates up to nine additional Channel Modules (sources are then numbered 01 thru 10 in the SSC, and 11 thru 19 in the SSCX).

1.1.3 The SSC may be equipped with either or both of two accessories.

1.1.3.1 A 12-button Keypad may be mounted in an opening provided in the top center of the front panel. This Keypad permits manual selection of the SOURCE PRESET (to run next). In automation system operation, this provides added flexibility in handling abnormal situations, such as inserting Weather Bulletins into the program sequence.

1.1.3.2 An ALARM circuit card may be plugged into the printed circuit card enclosure area. This card monitors the circuit which starts each new source. If a source is not ready when the start pulse is delivered, an Alarm condition exists. Provision is made for automatic correction of this condition by generation of an advance pulse to the associated system programmer, which causes a new SOURCE PRESET selection. This action may be delayed by a period adjustable between 1 and 10 seconds.

#### 1.2 APPLICATION

1.2.1 The System Switching Center may be operated manually to provide a Semi-Automatic program switcher. Since provision is made for remote control and display of operating functions, the SSC need not be located at the operating position.

1.2.2 SOURCE PRESET selection may be provided by program sequence memory devices such as the KSP-10 System Programmer. In this application, the SSC causes the KSP-10 to advance to a new event each time a source is started, thus providing the SSC with fresh SOURCE PRESET selection data for up to ten sources (numbers 1-0).

1.2.3 A digital Clock and Time Selector (such as the TS-4) may be added to the above combination to permit clock controlled functions, such as system start in the morning, semi-hourly format adjustment to permit station I.D. announcements within the required intervals, etc. In this application the TS-4 is time programmed by the KSP-10 and generates output commands which are implemented by the SSC.

- 1.2.4 A Random Access Sub-Programmer, such as the RA-10 may be used with the SSC and as many as ten multiple cartridge playback units, such as the Gates G-24 Carousels.

**NOTE:** *If the total number of sources to be controlled is between 11 and 19 (inclusive) the SSCX will be necessary.*

In this application, one of the source numbers (usually 0) is a "call" for the Sub-Programmer, which then supplies the number of the SOURCE PRESET.

The RA-10 may be used with the KSP-10 to provide a flexible but straightforward dual memory program sequence control group. The KSP-10 provides the basic format sequence and the RA-10 provides the variable traffic events. The RA-10 may be used without a system programmer to provide programmed traffic events in a Semi-Automatic system (see 1.2.1).

### 1.3 PHYSICAL DESCRIPTION

- 1.3.1 The System Switching Center is a single unit intended for rack mounting. It occupies six increments vertically (10½ inches). The Nine Source Extender occupies four increments (7 inches) and usually mounts just below the SSC.

- 1.3.2 Connecting cables from the program sources (one each) terminate on printed circuit edge connectors at the rear of the unit.

- 1.3.3 Connections to other system components (such as the Audio Control Center and Program Logging System) are made via rear mounted plug and socket connectors.

- 1.3.4 Provision is made in the printed circuit card enclosure area for three interface cards. These cards serve as logic and signal level translators for such units as the KSP-10 System Programmer, the TS-4 Time Selector, and RA-10 Sub-Programmer. Each of these requires a unique interface card.

- 1.3.5 Connections between the KSP-10, the TS-4, the RA-10, and the SSC are made with multiple, controlled impedance, twisted pair cable, which is required for proper transmission of the high speed digital signals passing between these units.

### 1.4 SPECIFICATIONS

Input Power:	117/234 ±10% VAC, 50/60 Hz
Operating Temperature:	+10° C to +55° C (+50° F to +131° F)
Gain:	Unity
Response:	±1 dB, 30 to 15 kHz
Crosstalk (Between Input Channels):	70 dB below program
Noise:	-70 dBm
Input/Source Z:	600 ohm resistive, unbalanced
Load Z:	600/150 ohms, floating
Output Level:	+10 dBm max. at less than 1% THD, 30 Hz to 15 kHz

Source Units:

(Ten maximum, nineteen with Nine Source Extender - )

Gates Criterion 80, Compact Criterion, 855 Multiple Cartridge Handler, Reel-to-Reel Machines with Gates DCU-3 Detector Control Unit, G-24 Multiple Cartridge Handler.

Dimensions:

Height - 10.47 inches

Panel - EIA notch pattern

Width -

Panel - 19 inches

Enclosure - 17¼ inches (over hardware)

Depth -

(Behind Panel) - 12½ inches over cable connectors

## 2.0 INSTALLATION

- 2.1 Carefully unpack the System Switching Center, and remove all module retaining packing. See that all plug-in printed circuit cards are properly seated in their sockets.
- 2.2 Remove the top cover. Inspect the Numitron display tubes and see that they are firmly seated in the right-hand socket (as viewed from the front) in each display area.
- 2.3 If a Nine Source Extender is to be used with the SSC, unpack the two Numitron display tubes supplied with it and install them in the left-hand socket in each display area of the SSC.
- 2.4 If the 994-6885 Keypad option is to be provided, install it as follows:
- 2.4.1 Remove the blank plate from the SSC panel opening. Save the nuts and washers.
- 2.4.2 Mount the Keypad (with the connector stakes at the bottom) using the washers and nuts removed in step 2.4.1.
- 2.4.3 Push the cable connectors (J4, J5) onto the stakes so that wire number 34 is at the far left (as viewed from the front) and wire number 157 is at the far right.
- 2.5 If the unit is to be operated from a 234 Volt, 50/60 Hz power source, the power transformer primary windings connections should be connected as shown below.

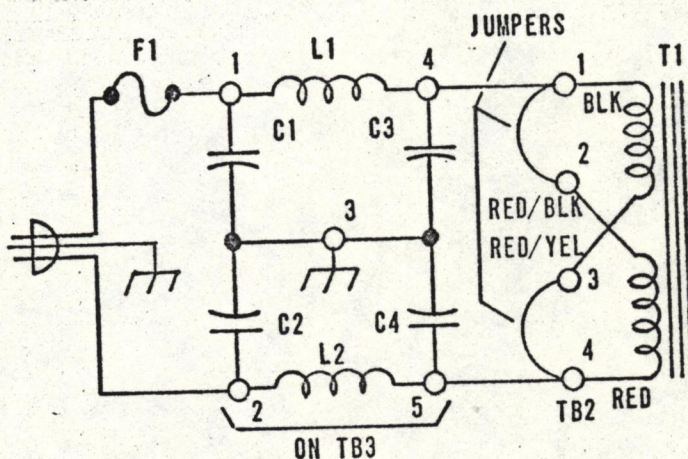

117 VOLT AC CONNECTIONS

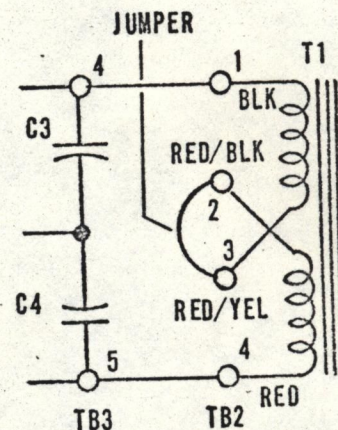

234 VOLT AC CONNECTIONS

- 2.6 Reinstall the top cover.
- 2.7 Mount the SSC in a standard 19" equipment rack, preferably with the bottom edge of the panel between 34" and 52" above the floor.
- 2.8 Install the SSCX (if used) just below the SSC. Connect the SSCX cable plug to J3 of the SSC.

- 2.9 If additional 994-6882 Channel Modules are to be installed, insert each printed circuit card assembly in an appropriate location in the lower card enclosure area.
- 2.10 If a Nine-Source Extender is used, remove the PRESET 1-0 circuit card from J12 of the SSC, and replace it with the PRESET 01-19 circuit card packed with the SSCX.
- 2.11 Assemble interconnecting cables (from the various program sources to the SSC) as shown in figures 6-1, 6-2, and 6-3.
- 2.12 Install the cables between the sources and the SSC, connecting each to the proper Channel Module by pressing the connector assembly socket over the Channel Module printed board plug, and secure it by pressing in on the black nylon latch buttons.
- 2.13 If the SSC is to be used with a KSP-10 System Programmer, a TS-4 Time Selector, or a RA-10 Random Access Sub-Programmer, or any combination of these units, appropriate Logic Interface printed circuit modules must be installed.
- These modules may be installed in any order in the three locations provided in the upper card enclosure area.
- 2.14 Interconnecting cables between the Logic Interface modules and their parent units must be fabricated from multiple controlled impedance twisted pair cable. (Schematics for these cables are in the appropriate technical manuals.)
- 2.15 Install the interface interconnecting cable by placing the lower end of the connector assembly mounting plate in the slot provided, swinging the connector over the printed board plug. Retain the upper end with the quarter-turn fastener.
- 2.16 If the 994-6884 ALARM circuit card option is to be used, connect the two circuit options as required (see Circuit Description) and install the card in the upper SSC circuit card enclosure area at J9.
- 2.17 Connect the a.c. power cord to an appropriate power source. The equipment is now ready for operation.
- 2.18 If a Remote Control device is provided, connect it to SSC connector J6.
- NOTE:** *Some of the circuits present at J6 are made available for special system applications and are not intended for use by any Remote Control equipment. DO NOT use these circuits without consulting the Gates Radio Company applications specialists.*
- 2.19 Program and Audition audio outputs appear on terminals of connector J1 (see page 2-6).
- Program output may be changed from 600 ohms to 150 ohms by moving the jumper on the Booster Amplifier circuit card.
- 2.20 Audition output (selected by the front panel AUDITION SELECTOR switch) is not isolated from the sources and must feed a bridging load, such as the AUXiliary input of a Gates Audio Control Center.

- 2.21 If a common circuit audio fade control (such as the Gates Motor Driven Fader) is to be included in the SSC Program Audio output circuit, its audio and control circuit connections are made to SSC connector J1.
- Audio output from the fader is then taken to the next audio unit (such as the Gates Audio Control Center).
- 2.22 In systems employing the Gates Fade-In equipment, control circuit connections for this unit are made to SSC connector J1.
- 2.23 Logging Circuit Output is available on SSC connector J2 (see page 2-7).
- 2.24 Outputs from the optional Alarm Circuit card are available on connector J2.
- 2.24.1 The ALARM 2 circuit is isolated from ground and should be limited to resistive loads, 117 volts, and 50 watts.
- 2.24.2 The ALARM 3 circuit is closed to control ground and should be limited to 45 volts, 100 mA non-inductive loads.

## SSC CONNECTOR J1 – OUTPUT

### TERMINAL

1	Control Circuit Common
2	Left Audio, Lo (Mono Out, Lo)
3	Left Audio, Hi (Mono Out, Hi)
4	Audio Shield Ground (Chassis)
5	Right Audio, Lo
6	Right Audio, Hi
7	Dead Roll Start
8	Fade In-Progress (EOM Inhibit)
9	Fade Start
10	Fade Complete
11	Transition (Fade Release)
12	
13	Left Audition Shield
14	Left Audition Lo
15	Left Audition Hi
16	Right Audition Shield
17	Right Audition Lo
18	Right Audition Hi
19	
20	Transition (Fade-In)
21	Sequence (Emerg Advance)
22	Start
23	EOM Lamp (Emerg Start)
24	+24 Volts (to Control Common)

## SSC CONNECTOR J2 – LOGGING & ALARM

### TERMINAL

1	Control Circuit Ground
2	Alarm 2
3	Alarm 2
4	Alarm 3 Closure to Control Ground
5	Logging Data Output
6	
7	
8	
9	
10	
11	
12	
13	
14	
15	

1143

SSC CONNECTOR J3  
NINE-SOURCE EXTENDER

1.	COMMON (0 V.)			26.	PROGRAM DISPLAY 5
2.	EOM			27.	"        "    6
3.	—			28.	"        "    7
4.	—			29.	"        "    8
5.	—			30.	"        "    9
6.	—			31.	—
7.	LOGGING			32.	SELECT 1
8.	PRESET BUSY 0 (10-19)			33.	SELECT 2
9.	PRESET HOLD 0 (10-19)			34.	SELECT 3
10.	PRESET DISPLAY 1			35.	SELECT 4
11.	"        "    2			36.	SELECT 5
12.	"        "    3			37.	SELECT 6
13.	"        "    4			38.	SELECT 7
14.	"        "    5			39.	SELECT 8
15.	"        "    6			40.	SELECT 9
16.	"        "    7			41.	—
17.	"        "    8			42.	START/READY
18.	"        "    9			43.	START/RUN
19.	—			44.	TRANSITION
20.	PROGRAM BUSY 0 (10-19)			45.	RIGHT AUDITION AUDIO
21.	PROGRAM HOLD			46.	LEFT AUDITION AUDIO
22.	PROGRAM DISPLAY 1			47.	RIGHT PROGRAM AUDIO
23.	"        "    2			48.	LEFT PROGRAM AUDIO
24.	"        "    3			49.	AUDIO SHIELD RETURN
25.	"        "    4			50.	+24 VOLTS

## SSC CONNECTOR J6

### REMOTE CONTROL

<ul style="list-style-type: none"> <li>* 1. DECADE SELECT 0</li> <li>2. GROUND (0 V.)</li> <li>* 3. +5 V</li> <li>* 4. SEQUENCE</li> <li>5. +24 V</li> <li>6. RESTORE SUB</li> <li>7. ALARM 3</li> <li>8. E-O-M LAMP</li> <li>9. HOLD LAMP</li> <li>10. READY</li> <li>11. RESTORE MAIN</li> <li>* 12. TRANSITION</li> <li>* 13. READ</li> <li>14. ADVANCE</li> <li>15. RUN/RUN LAMP</li> <li>16. START</li> <li>17. DEAD ROLL</li> <li>18. (n. c.)</li> </ul>	<div style="border-left: 1px solid black; border-right: 1px solid black; height: 400px; margin: 0 auto;"></div>	<ul style="list-style-type: none"> <li>19. FADE</li> <li>20. SKIP (B)</li> <li>* 21. DECADE SELECT 1</li> <li>22. (n. c.)</li> <li>23. (n. c.)</li> <li>24. DATA KEY 0</li> <li>25. " " 1</li> <li>26. " " 2</li> <li>27. " " 3</li> <li>28. " " 4</li> <li>29. " " 5</li> <li>30. " " 6</li> <li>31. " " 7</li> <li>32. " " 8</li> <li>33. " " 9</li> <li>* 34. SELECT COMMON</li> <li>35. HOLD</li> <li>36. STOP</li> </ul>
--	---	---

\* = Circuit not intended for Remote Control.

Do not make connections without consulting factory.

## 3.0 OPERATION

### 3.1 PRELIMINARY OPERATIONAL CHECKS

- 3.1.1 Check the operation of the Keypad (if provided) in ten source systems (SSC without SSCX) as follows:
- 3.1.1.1 As each Keypad source number button is pressed (for which a Channel Module is in place), the SOURCE PRESET display should show the corresponding number.
  - 3.1.1.2 Simultaneous operation of two or more buttons will produce no change in the number displayed.
  - 3.1.1.3 If the same button is operated successively, the display will be seen to blink off momentarily, as the appropriate Channel Module relay first restores and then reoperates.
  - 3.1.1.4 No selection should be possible where a Channel Module is not installed.
- 3.1.2 Check the operation of the Keypad (if provided) in nineteen source systems (SSC plus SSCX) as follows:
- 3.1.2.1 If the SOURCE PRESET display is dark, Keypad buttons 2 thru 9 are inoperative. If displaying a two digit number, the display will go dark if any button 2 thru 9 is pressed.
  - 3.1.2.2 Buttons 1 and 0 serve as prefix numbers. When pressed, the left hand Numitron (in the SOURCE PRESET display) will show the "tens" selection. The right hand Numitron will be dark, since no "units" selection has been made.
  - 3.1.2.3 After making a "tens" selection (1 or 0), pressing any Keypad number button will complete the selection and the "units" number will be displayed with the "tens" digit in the SOURCE PRESET display (if the selected Channel Module is in place).
  - 3.1.2.4 Rollover (two keys pressed so that one is still down when the second is pressed) while making the "tens" selection will result in a "last pressed" selection of the tens digit. Rollover from the "tens" selection to the "units" selection (other than 1 or 0) will work properly.
- 3.1.3 Reading a SOURCE PRESET selection from the main System Programmer (KSP-10, etc.) or Sub-Programmer (RA-10, etc.) may be checked as follows:
- 3.1.3.1 Load the desired source selection number into the Programmer display.
  - 3.1.3.2 Press the # button (for main) or \* button (for Sub) on the Keypad. The desired number will appear in the PRESET display window (when the button is released, if from the Sub-Programmer).
  - 3.1.3.3 If the SSC is not equipped with a Keypad, the main programmer load may be accomplished with the STOP switch pushbutton.
- 3.1.4 The "READY" condition sensor is checked as follows:
- 3.1.4.1 Make a SOURCE PRESET selection.

- 3.1.4.2 See that the lamp in the yellow (STOP) button is illuminated if the source is truly ready to run; i.e., tape is loaded and power is on, but tape is not moving. If tape is unloaded or playing or if power to the source is off, the READY will be dark.
- 3.1.4.3 Audio only sources, such as a network or a simulcast feed will always be "READY".
- 3.1.5 The Start Pulse Memory is checked as follows:
  - 3.1.5.1 Proceed as in 3.1.1, 3.1.2, or 3.1.3 to make a source selection.
  - 3.1.5.2 If an ALARM circuit card is present, unplug it for this test.
  - 3.1.5.3 Make the source non-ready by turning off power or unloading the tape.
  - 3.1.5.4 Press the red (START) button. It will illuminate and remain illuminated after the red button has been released and until the yellow (STOP) button has been pressed.
  - 3.1.5.5 If the READY condition returns while this START pulse is in storage, a START function will occur as in 3.1.6.
- 3.1.6 The source START function may be checked as follows:
  - 3.1.6.1 Select an operable source and load it with a tape containing an End-Of-Message (EOM) signal.
  - 3.1.6.2 Press and hold the red (START) button.
  - 3.1.6.3 The red and yellow buttons will both be illuminated and the selected (SOURCE PRESET) machine will start to run.
  - 3.1.6.4 If a System Programmer is connected and is in AUTO mode, it will advance one event.
  - 3.1.6.5 Release the red button. It will go dark. Also, the source number will now appear in the PROGRAM OUTPUT display window.
  - 3.1.6.6 If a number is visible in the NEXT window of the Programmer and the Programmer is not searching, this number will appear in the SOURCE PRESET window of the SSC.
- 3.1.7 The EOM circuit may be checked as follows:
  - 3.1.7.1 Start a tape as in 3.1.6.
  - 3.1.7.2 When the EOM signal is detected by the program source machine, the red (START) button will be illuminated for the duration of the EOM signal.
  - 3.1.7.3 At the end of the EOM signal (when the red button goes dark), the source number will disappear from the PROGRAM OUTPUT display window.
- 3.1.8 The RUN function of the SSC may be checked as follows:
  - 3.1.8.1 Press the green (RUN) button. It will illuminate. Press the yellow (STOP) button. The green button will go dark.
  - 3.1.8.2 Select a source as in 3.1.6.

- 3.1.8.3 Put the SSC in the RUN mode (press the green button).
- 3.1.8.4 Start the source (press the red button). The source will start.
- 3.1.8.5 Select a new source.
- 3.1.8.6 When the first source EOM is received, the new source will start and the red button will light.
- 3.1.8.7 When the EOM is complete, the PROGRAM OUTPUT display will change to show the new source number, the red button will go dark, and the SOURCE PRESET display will show a new number (if available) or go dark.
- 3.1.9 The HOLD function may be checked as follows (if a System Programmer is connected to the SSC):
  - 3.1.9.1 Select a source as in 3.1.6.
  - 3.1.9.2 Press the white (HOLD) button. The button will stay illuminated.
  - 3.1.9.3 Start the source (press the red button).
  - 3.1.9.4 When the red button is released, the white button will go dark.
  - 3.1.9.5 The Programmer will not have advanced and the SOURCE PRESET display will once again show the number in the Programmer NEXT display.

## 3.2 ROUTINE OPERATION IN AUTOMATION SYSTEMS

- 3.2.1 Turn on power for all automation system control and source equipment.
- 3.2.2 Prepare System Programmer (KSP-10, etc.) so that first event is in the NEXT display window. Programmer should be in AUTO mode.
- 3.2.3 Press yellow (STOP) button or # button (if Keypad is provided). First event will appear in SOURCE PRESET display window.
- 3.2.4 If the Time Selector is to start the system, load the time/function data into the Time Selector. The system will start itself when the chosen time occurs.
- 3.2.5 If the system is to be started manually, press the green (RUN) button when 3.2.3 has been done. Then press the red (START) button when the first event is to be put on air.

## 3.3 SEMI-AUTOMATIC OPERATION IN THE NON-AUTOMATION SYSTEMS

- 3.3.1 Select a source with the local Keypad (if provided) or the remote control Keypad (or equivalent button group).
- 3.3.2 If the yellow button lights, the source is READY.
- 3.3.3 Press the red (START) button. The source will start.
- 3.3.4 Make a new source selection.
- 3.3.5 If the new source is to be started before the old source program ends, it is necessary to hold the START button depressed as long as the old program is desired. Overlap is controlled by the START button.

3.3.6 While it is not necessary to use EOM signals on tape cartridges when the SSC is used in Semi-Automatic operation, two operating advantages develop from their use:

3.3.6.1 The EOM signal will light the red (START) button for its duration, serving as an alerting signal to the operator of the upcoming end of the program.

3.3.6.2 The end of the EOM signal will release the audio switching relay in the Channel Module, opening the path and reducing the possibility of undesirable sounds reaching the air.

3.4 **OPERATION IN SYSTEMS WITH MAIN AND SUB-PROGRAMMERS**

3.4.1 A typical configuration would include a KSP-10 (or 19) System Programmer (main) and an RA-10 Random Access Sub-Programmer.

3.4.2 Each requires an appropriate Logic Interface board to be installed in the SSC (see 2.13 thru 2.15).

3.4.3 The lower right Keypad button (#) serves as a "RESTORE MAIN" operator. When pressed, it "asks" the System Programmer to load the SOURCE PRESET (see 3.1.3.2 and 3.1.3.3).

3.4.4 If the number supplied by the System Programmer is the one to be recognized by the Sub-Programmer as a call for it to supply the SOURCE PRESET number the Sub-Programmer source number will appear when the button is released.

3.4.5 If the Sub-Programmer event does not include the "End-of-Cluster" function code (0), the SSC HOLD function will be set up concurrently with the appearance of the Sub-Programmer source number in the SSC SOURCE PRESET window.

3.4.6 The lower left Keypad button (\*) serves as a "RESTORE SUB" operator. When pressed, it "asks" the Sub-Programmer to load the SOURCE PRESET. If the "End-of-Cluster" function code is not a part of the current Sub-Programmer event, the HOLD function will be set up, too.

3.4.7 The Sub-Programmer will retain control of the sequence as long as its events do not contain "End-of-Cluster" code and the System Programmer is displaying the number which calls on the Sub-Programmer.

3.5 **OPERATION IN SYSTEMS AS A SWITCHER FOR SUB-PROGRAMMER**

3.5.1 An interface device is provided with the system to permit the SSC to work into an SC-48, SP-10/19, or SP-810/819 system as if it were a single source.

3.5.2 A Keypad is usually unnecessary and is not provided unless specifically required by the user.

3.5.3 System wiring is arranged so that the RA-10 Logic Interface recognition circuit is activated by the STOP button so that the Sub-Programmer will load the SOURCE PRESET when the STOP button is pressed and released. The HOLD function will be set up if the Sub-Programmer function code is not 0 (End-of-Cluster).

3.5.4 The START, RUN, STOP, and E-O-M circuits are controlled by the system interface (3.5.1).

## 4.0 CIRCUIT DESCRIPTION

### 4.1 POWER SUPPLY

- 4.1.1 The power supply circuits consist of transformer T1, fuse F1, series regulator transistor Q1, integrated circuit regulator U1 (all on the main chassis), and the power supply printed circuit board 992-3281.
- 4.1.2 The power transformer primary windings may be connected in series for 234 Volt a.c. lines or in parallel for the usual 117 Volt a.c. line. (See Section 2.5.)
- 4.1.3 T1 secondary number 2 is connected to rectifier diodes CR1 and CR2 on the printed board. The full wave output of these diodes is smoothed by capacitor C3 and delivered to the 5 Volt regulator U1. The output of U1 is fed to the SOURCE PRESET and PROGRAM OUTPUT display circuits and to J17, J18, and J19 for the Logic Interface circuit cards required by such system components as the KSP-10 System Programmer, the TS-4 Time Selector, and the RA-10 Sub-Programmer.
- 4.1.4 T1 secondary number 1 is connected to rectifier diodes CR3 and CR4 on the printed board. Capacitor C1 smooths this rectified voltage, which is fed to the emitter of regulator transistor Q1 on the main chassis.
- 4.1.5 Zener diode CR5 supplies a reference for the base of error voltage amplifier Q1 on the printed board. Resistor R1 and diode CR7 provide an emitter reference for this transistor, holding the emitter near the COMMON output circuit as long as the transistor needs less than the full current available from R1 (about 120 mA at normal output voltage).
- 4.1.6 Printed board transistor Q1 collector current is drawn from base of regulator transistor Q1 on the main chassis. Any difference between the COMMON output line (as seen by the emitter of printed board transistor Q1) and the reference voltage across CR5 (as seen at the base of the transistor) is amplified and fed to the chassis mounted regulator transistor, which adjusts the current flow from the UNREG line on its emitter to the COMMON on its collector, thus maintaining the +24 Volt output of the supply.
- 4.1.7 If the output current drawn from the power supply exceeds the product of the Beta of regulator transistor Q1 (on the main chassis) and the normal current in R1 on the printed board, the voltage drop across R1 will exceed the reference voltage of CR5, and CR7 will cease to conduct. At this point, the output current becomes limited and the output voltage falls as current increases.
- 4.1.8 When the output voltage falls below the reference voltage (CR5), diode CR6 begins to conduct, reducing the voltage across CR5. As this reference voltage drops, the current in R1 (and thus the base current of regulator transistor Q1 on the main chassis) drops, and the power supply output "folds back" to a short circuit current of about 70 mA, thus protecting all of the components in the power circuit.
- 4.1.9 Capacitor C2 provides some transient surge protection, adding to the stability of the regulator circuits.
- 4.1.10 Resistors R4 thru R7 provide lamp current limiting to extend the life of the front panel indicators.

## 4.2 CHANNEL MODULE

- 4.2.1 One Channel Module serves each program source in the automation system. It contains two relays and the required silicon controlled rectifiers (SCR's) to operate them.
- 4.2.2 Most of the Channel Module circuits to and from the SSC are multiple with other Channel Modules. The exceptions are the AUDITION audio circuits, the SELECT circuit, and PRESET and PROGRAM readout circuits.
- 4.2.3 When a particular channel is selected to be the next program source, its SELECT circuit is momentarily held near 0 Volts (COMMON). This turns on Q1, which in turn supplies current for the gate of SCR Q2. Q2 comes on and energizes K1.
- 4.2.4 Relay K1 sets up four circuits:
- 4.2.4.1 COMMON is connected to diodes CR6 and CR7, energizing the appropriate PRESET READOUT and PRESET BUSY (see SELECTOR CIRCUITS).
- 4.2.4.2 The TRANSITION circuit is connected to the base circuit of Q3 and the anode circuit of Q2.
- 4.2.4.3 The START/READY and START/RUN circuits of the source are connected to the corresponding busses (see START CIRCUIT).
- 4.2.5 At some later time, the TRANSITION circuit is held low (near 0 Volts) temporarily. At the beginning of this interval, transistor Q3 is turned on which in turn fires SCR Q4, energizing relay K2.
- 4.2.6 Simultaneously, CR2 conducts because its cathode voltage is nearer COMMON than is the cathode of SCR Q2. When CR2 conducts, SCR Q2 is starved and shuts off. Relay K1 remains energized, however, until the TRANSITION line returns to its high state.
- 4.2.7 When K2 operates, it closes six circuits.
- 4.2.7.1 The Left and Right audio inputs are connected to bridging resistors R11 and R12 and thus to the program audio busses which connect to the Booster Amplifier inputs.
- 4.2.7.2 The Source Logging circuit is connected to the Logging output via the common Logging bus.
- 4.2.7.3 COMMON is connected to diodes CR8 and CR9, energizing the appropriate PROGRAM READOUT and PROGRAM BUSY (see PROGRAM RELEASE CIRCUITS).
- 4.2.7.4 The source EOM line is connected to the EOM bus thru R13 and to the anode circuit of SCR Q4 via CR5.
- 4.2.7.5 The TRANSITION circuit is also connected to the anode of Q4, via CR3, after K1 restores.
- 4.2.8 An incoming EOM signal from the source is passed to the EOM bus (see MODE CONTROL) via R13, and during its presence, CR5 conducts, starving Q4. K2 remains operated until the end of the EOM signal.

4.2.9 A TRANSITION signal will also release K2 at its conclusion, since CR3 will conduct, starving Q4.

#### 4.3 **START CONTROL**

4.3.1 The selected source START/READY and START/RUN circuits are passed thru the active Channel Module to the Start Control printed circuit card.

4.3.2 Transistors Q7 and Q8 and their associated components constitute a sampling circuit which causes Q7 to be "on" if, and only if, a source (with "battery switching" control circuitry, such as Criterion 80 equipment) is loaded with tape, power on, but not running.

4.3.3 Transistor Q9 performs the same test for "ground switching" sources (such as the Criterion Compact series).

4.3.4 Transistors Q6, Q5, Q4, and their associated components are a "slow-on/fast-off" timing circuit, providing drive for the base of Q3 about one-half second after a "Ready" condition is sensed.

4.3.5 Transistor Q3 is the reference switch for K1.

4.3.5.1 If Q3 is on ("Ready" exists), a low (near COMMON) signal on the START circuit will energize K1.

4.3.5.2 If Q3 is off, a low on the START circuit will not energize K1, but will turn on the latch circuit consisting of Q1 and Q2.

4.3.5.3 This "stored" START signal will be retained until a Ready condition exists or until cancelled by a signal on the STOP circuit, which turns off Q2, releasing the latch.

4.3.6 When K1 operates, it closes the START/READY to the START/RUN, which causes the source tape transport to begin play. Also, K1 closes the TRANSITION circuit to COMMON, initiating the audio switching sequence in the Channel Module and the SEQUENCE chain in the Mode Control Circuitry (via CR11).

4.3.7 When the START/READY to START/RUN closure occurs, the Ready condition (which turns on Q6, Q5, and Q4) is lost. Resistor R8, however, provides an alternate base current path for Q3, keeping the circuit active as long as the START circuit remains low.

4.3.8 Diodes CR6 (prior to the arrival of the START signal) and CR5 (during TRANSITION) cause the READY circuit (and the yellow button illumination) to be activated.

4.3.9 Diode CR12 causes the SEQUENCE chain (in the Mode Control circuit) to be initiated when a SKIP command is received (from a Time Selector such as the TS-4).

#### 4.4 **MODE CONTROL**

4.4.1 The circuit consisting of K1, Q1, and their associated components form the RUN circuit. A low applied to the RUN/RUN LAMP circuit energizes K1. Transistor Q1, normally held on by base current through R2, CR2, holds K1 operated. A low on the STOP lead turns Q1 off, releasing K1.

- 4.4.2 Transistors Q5 and Q4 serve as an EOM current amplifier. An EOM signal from an "on-air" source comes thru R13 in the active Channel Module to the EOM bus and to the base circuit of Q5. The voltage drop across diodes CR12, CR13, and CR14 is insufficient to cause them to conduct if only one source is supplying an EOM signal.
- 4.4.3 If two sources supply EOM signals at the same time, the voltage drop across the three diodes is sufficient to cause conduction. This turns on Q6, which shunts the base circuit of Q5, turning it off. Thus two EOM signals are interpreted as no EOM signals. Thermistor R13 compensates for the change in forward voltage drop (on the diodes) with a change in temperature.
- 4.4.4 During a program fade-out (as generated by a companion unit such as the Gates Motor Driven Fader), the EOM INHIBIT circuit is held low, turning on Q6 and preventing recognition of any EOM signal.
- 4.4.5 The output of Q4 operates the EOM lamp, and, if K1 is operated (RUN mode active), the START circuit is activated.
- 4.4.6 Diode CR4 is arranged to allow a START signal (active or stored in the Start Control circuit) to operate the EOM lamp in the red (START) button.
- 4.4.7 Pressing the HOLD button (white) puts a low signal on the HOLD circuit. This turns on Q3, which turns on SCR Q2. Q2 energizes relay K4, which, in turn, provides a low to illuminate the lamp in the HOLD button.
- 4.4.8 K4 also prepares a release path, from the STOP circuit to the anode circuit of Q2 via diode CR11. When the STOP circuit is activated, CR11 conducts and CR10 and the SCR (Q2) are starved and turn off. When the STOP circuit is released, K4 restores.
- 4.4.9 When the SEQUENCE circuit is energized (see 4.3.6 and 4.3.9), relay K2 is energized.
- 4.4.9.1 When K2 operates, the RESTORE circuit is opened to prevent manual interference during a TRANSITION.
- 4.4.9.2 During the operated interval of K2, capacitor C1 is charged thru R3.
- 4.4.10 The SEQUENCE signal is repeated (when K2 operates) to the ADVANCE circuit (if K4 is not operated), and thus causes the System Programmer to move ahead one event.
- 4.4.11 If K4 is operated (HOLD is active), the ADVANCE circuit is not activated. Instead, the SEQUENCE signal is passed to the anode circuit of SCR Q2, starving it, which allows K4 to restore at the end of the SEQUENCE signal.
- 4.4.12 Typically, a System Programmer will hold the ADVANCE circuit low until it has completed its cycle. This causes K2 to remain operated (and the SEQUENCE line held low) until the Programmer releases the ADVANCE circuit.
- 4.4.13 When K2 restores, the charged capacitor, C1, is connected to the coil of relay K3, causing it to operate for about 0.1 second.
- 4.4.14 While K3 is operated, COMMON is extended on the READ circuit. This circuit goes thru the Programmer (or its interface equipment) and returns a source selection circuit closure to determine the next SOURCE PRESET.

## 4.5 PROGRAM DISPLAY

- 4.5.1 Integrated circuits U101, U102, and U103A constitute a decimal to BCD encoder, serving Channel Modules 1 thru 9 and 11 thru 19.
- 4.5.2 The BCD code is passed thru latch U106 and on to BCD-to-seven-segment decoder U104. U104 illuminates the proper segments of Numitron display tube V101.
- 4.5.3 In the event that no Channel Module program circuit relay is operated, the BCD code presented to U104 would display a "0". U104 has a zero suppression circuit, however, and the zero is not displayed unless the "0" Channel Module relay is operated and completing the circuit thru U103B, latch U107, to U104.
- 4.5.4 Q101 and Q102 are inverters serving the PROGRAM BUSY 10-19 and PROGRAM BUSY 01-09 circuits. Q101, thru latch U107, controls U105B, which illuminates the segments (of Numitron display tube V102) required to display a "1". Q102, thru latch U107, controls U105A and U105B, causing display of a "0".
- 4.5.5 During TRANSITION, two Channel Module program relays may be operated. The resulting display would often be ambiguous. Q103, operated from the TRANSITION circuit, controls the latches, U106 and U107, retaining the display of the source "on-air" before the TRANSITION until the TRANSITION is complete, at which time only one Channel Module relay is operated, and the latch is released, allowing the new source number to be displayed.

## 4.6 PRESET DISPLAY

- 4.6.1 The Preset Display circuitry is the same as the Program Display circuitry except that no latch is provided.

## 4.7 PROGRAM RELEASE

- 4.7.1 This circuit works in conjunction with common audio fade control equipment such as the Gates Motor Driven Fader.
- 4.7.2 Any operated Channel Module program relay maintains a low on one of the PROGRAM BUSY circuits. The FADE COMPLETE circuit is normally open, and therefore "high" (about +12 Volts).
- 4.7.3 During this time, Q3 is on (R4 and R9), Q2 is on (R4 and R8) and Q1 is off since no voltage exists across R5 (PROGRAM BUSY is low) or R6 (Q2 is on).
- 4.7.4 With Q3 on, Q4 is held off and R18 is allowed to turn on Q6. Q6 provides the holding circuit for all Channel Module program relays.
- 4.7.5 At the conclusion of a fade-out, a FADE COMPLETE pulse (low) is received.
- 4.7.6 During this interval, Q3 loses both sources of base current. The "latch" circuit consisting of Q1 and Q2 does not change state, since Q2 is on, holding Q1 off, and Q1 being off allows R3 and R7 to hold Q2 on.
- 4.7.7 Since Q1 and Q3 are now both off, Q4 is turned on by R16 and R14, and Q6 is turned off, releasing all Channel Module program relays. The PROGRAM BUSY circuit is no longer held low.

- 4.7.8 Q1 and Q3 are now turned on (R1, R5, and R10), which again turns Q4 off and Q6 on. Q2 is now turned off, allowing R17 to turn Q5 on, generating an EOM signal which goes to EOM lamp (in the red button) and to the Mode Control circuits. If the RUN mode is active, a new START sequence is initiated.
- 4.7.9 When TRANSITION energizes a new Channel Module program relay, the PROGRAM BUSY circuit again goes low. Q3 is again turned off, but Q1 and Q2 do not change state, and Q1 holds Q4 off so that Q6 remains on.
- 4.7.10 The TRANSITION signal is sent to the Motor Driven Fader, causing it to release, and terminating the FADE COMPLETE signal.
- 4.7.11 At the conclusion of the FADE COMPLETE signal, Q3 is again turned on, and Q1 and Q2 revert to their original state (Q1 off, Q2 on), turning off Q5.

## 4.8 SELECTOR CIRCUITS

- 4.8.1 The Selector Circuits employed in the SSC consist of the Selector Control circuit, the Selector Matrix, and either the Preset Control "1-0" (if no SSCX is used) or Preset Control "01-19".
- 4.8.2 The Selector Matrix serves as a button closure sensor, providing an output current at the SELECT INTERLOCK terminal proportional to the number of source select pushbuttons depressed (current thru even numbered resistors R2 thru R20) and also as a ten circuit switch. If the SELECT LOCKOUT line is held high (near +24 Volts), the low generated by pressing a source select button is lost across the corresponding odd-numbered resistor (R1-R19) and does not turn on transistor Q1 in the Channel Module.
- 4.8.3 The Selector Control circuit has a current sensing circuit similar to that of the EOM circuit in the Mode Control (see 4.4.2 and 4.4.3). If only one button is pressed, Q8 turns on, which turns on Q11.
- 4.8.4 If two or more buttons are pressed, Q7 turns on, turning on Q9 and inhibiting Q11. Also, Q10 is turned on, which pulls the SELECT LOCKOUT high, preventing a new selection. (See 4.8.2 above.)
- 4.8.5 Diodes CR12 and CR13 permit the TIME GATE circuit (not used in SSC) and the TRANSITION circuit to lock out the SELECT circuits.
- 4.8.6 When a normal selection is made (one button), Q11 generates a SELECT COMMON signal.
- 4.8.7 The Preset Control "1-0" circuit card employs a circuit much like the Program Release circuit (see 4.7) to cause the release of any operated Channel Module preset relay before a new selection can be made.
- 4.8.8 The SELECT COMMON and PRESET BUSY circuits are applied to the Preset Control "1-0" circuit, thus providing the required release of the PRESET HOLD circuits when a change in selection is made.
- 4.8.9 In the Preset Control "1-0", Channel Modules 1 thru 0 are treated as belonging to one "tens" group.
- 4.8.10 When an SSCX is used with the SSC, the Preset Control "1-0" circuit card is replaced with the Preset Control "01-19" circuit card. This card has the additional circuitry required to provide two-digit selection of source numbers.
- 4.8.11 Source selector buttons (DATA KEYS) 1, and 0 have a direct path to the Preset Control "01-19" card, and a new circuit, LOCKOUT AUX. is completed between Preset Control transistor Q11 collector and Selector Control transistor Q10 base.

- 4.8.12 The LOCKOUT AUX circuit keeps Q10 (Selector Control) turned on. Q10 keeps the SELECT LOCKOUT circuit high, so that none of the DATA KEY circuits may pass the Selector Matrix to the SELECT circuits of Channel Modules.
- 4.8.13 Pressing either 1 or 0 button does four things:
- 4.8.13.1 Turns on Selector Control transistors Q8 and Q11, generating the SELECT COMMON signal.
  - 4.8.13.2 Sets flip-flop Q4/Q7 (on the Preset Control "01-19" circuit card) through transistor switches Q8, Q9 and their associated components.
  - 4.8.13.3 Turns off transistor Q10.
  - 4.8.13.4 Energizes relay K1.
  - 4.8.13.5 When the button is released, K2 operates, with K1 and K2 being held by Q10.
- 4.8.14 The SELECT COMMON signal causes the release of any operated Channel Module preset relay (the Q1, Q2, Q3 circuit turns on both Q4 and Q7 until any operated relay restores, since Q4 turns off Q5 and Q7 turns off Q6).
- 4.8.15 The flip-flop (Q4, Q7) determines which tens group (01-09 or 10-19) may accept a selection, since only one or the other of Q5 or Q6 may be on at any time.
- 4.8.16 K1, when operated, extends the flip-flop output to the PRESET DISPLAY (D1 or D0) circuits to illuminate the proper tens digit display.
- 4.8.17 K2, when operated, turns off the LOCKOUT AUX transistor, Q11, and the flip-flop input switch transistors Q8 and Q9.
- 4.8.18 Second digit selection is now accomplished by pressing any of the appropriate buttons. When this is done (assuming only one button is pressed), the SELECT signal to the appropriate Channel Module causes the preset relay to operate in that module.
- 4.8.19 The SELECT COMMON signal which is generated at this time turns off Q10 (Preset Control "01-19"), which releases K1.
- 4.8.20 When the select button is released, K2 restores and Q11 is turned on, locking out all buttons except 1 or 0.
- 4.8.21 During the READ interval which follows the TRANSITION, SEQUENCE, and ADVANCE circuit operations (see 4.4), the System Programmer or Sub-Programmer will supply tens and units inputs simultaneously.
- 4.8.22 The tens input is received on either the DECADE SELECT 0 or DECADE SELECT 1 circuit. This input does four things:
- 4.8.22.1 The flip-flop is set directly (without operation of the SELECT COMMON circuit).
  - 4.8.22.2 Transistor switches Q8 and Q9 are turned off.
  - 4.8.22.3 Relay K2 is energized.
  - 4.8.22.4 LOCKOUT AUX transistor Q11 is turned off.

4.8.23 The units select input then acts in the usual way to cause the operation of the desired Channel Module preset relay.

4.8.24 At the end of this Programmer input signal, K2 restores and Q11 comes on, locking out units selection from the selector buttons.

#### 4.9 **BOOSTER AMPLIFIER**

4.9.1 The SSC Booster Amplifier is a conventional three-stage circuit with input and output transformers providing circuit isolation.

4.9.2 Transistor Q1 has some degenerative feedback in its emitter circuit, as well as r. f. protection in the form of capacitors C11 and C2.

4.9.3 Q2 drives the single-ended push-pull output stage, Q3, Q4.

4.9.4 R9 determines the no-signal output stage current, which is adjusted at the factory for minimum distortion vs. power dissipation.

4.9.5 C8 and R8 form a bootstrap current source for Q2 collector.

4.9.6 C9, R12, and R13 form an overall feedback loop, to the emitter of Q1.

#### 4.10 **ALARM CIRCUIT**

4.10.1 The optional Alarm Circuit card consists of an error condition sensor, an adjustable delay circuit with relay contact output, and a pulsed relay circuit with strappable options.

4.10.2 Q1 and Q2 are connected so that Q2 is on if a START signal is present and the READY signal is not.

4.10.3 Q3 (a unijunction transistor) and Q4 (a silicon Controlled Rectifier) make up a timing circuit which is adjustable from approximately 1 to 10 seconds.

4.10.4 At the end of the timing period, Q4 fires and K1 operates, closing the ALARM 3 circuit to COMMON, and closing the isolated ALARM 2 circuits.

4.10.5 Relay K2 is driven by Q5 which operates the relay during the charge interval of C2. The input to C2 may be wired so that K1 operates as soon as the error condition occurs (NORMAL) or after the delay determined by Q3 and Q4 (DELAYED).

4.10.6 K2 completes a circuit to COMMON which may be wired to ALARM 1 or to SEQUENCE.

4.10.7 A momentary signal delivered to the SEQUENCE circuit causes the System Programmer/Sub-Programmer to advance to the next event.

4.10.8 The ALARM circuits are available for use as the user requires. (See Section 2 - INSTALLATION.)

## PARTS LIST

## INDEX

PAGE	PARA.	ASSY. No.	COMPONENT
5-2	5.1	992-3280	System Switching Center (SSC) Main Assembly
5-3	5.2	992-3287	Selector Matrix Assembly (SSC)
5-3	5.3	992-3286	Program Display Component Board (SSC)
5-4	5.4	992-3335	Preset Display Component Board (SSC)
5-5	5.5	992-3301	Nine-Source Extender (SSCX) Main Assembly
5-5	5.6	992-3552	Channel Module Circuit Card
5-6	5.7	992-3290	Channel Module Cable Connector Assembly
5-7	5.8	994-6883	Booster Amplifier
5-8	5.9	994-6884	Alarm Circuit Card
5-9	5.10	994-6885	Keyset Assembly
5-10	5.11	992-3281	Power Supply Circuit Card
5-11	5.12	992-3777	Start Control Circuit Card w/Buffer
5-12	5.13	992-3283	Mode Control Circuit
5-13	5.14	992-3284	Preset Control "1-0" Circuit Card
5-14	5.15	992-3357	Preset Control "01-19" Circuit Card
5-15	5.16	992-3285	Program Release & Selector Control Circuit Card

## Mating Connectors

(For J1) 610 0530 000 Plug, 24 Circuit

(For J2) 610 0529 000 Plug, 15 Circuit

(For J6) 610 0531 000 Plug, 36 Circuit

354 0368 000 Terminal, crimp (for above  
connectors)

## SYSTEM SWITCHING CENTER (SSC) MAIN ASSEMBLY 992-3280

SYMBOL NO.	GATES PART NUMBER	DESCRIPTION
C1,C2,C3, C4	516-0082-000	Capacitor, Disc., .01 uf. 1 kv
DS1,DS2, DS3,DS4	396-0169-000	Lamp, 28V, .04A, Type 387
F1	398-0053-000	Fuse, 0.8 Amp, Slo-Blo
J1	612-0524-000	Receptacle, 24 circuit
J2	612-0523-000	Receptacle, 15 circuit
J3	612-0492-000	Receptacle, 50 circuit
J4	915-4634-001	Receptacle, 5 circuit
J5	915-4659-001	Receptacle, 8 circuit
J6	612-0513-000	Receptacle, 36 circuit
	354-0369-000	Crimp terminal for J1,J2,J6
	354-0371-000	Crimp terminal for J4,J5
J7,J8,J9, J10,J11,J12, J13,J14	612-0521-000	Connector, Printed Circuit 18 Circuit, Single Readout
J15-1 thru J15-10	612-0520-000	Connector, Printed Circuit 22 Circuit, Single Readout
J17,J18, J19	612-0533-000	Connector, Printed Circuit 36 Circuit, Double Readout
L1,L2	494-0256-000	Choke, 33 uh, 0.85A
Q1	380-0043-000	Transistor, 2N3055
R1,R2	540-0044-000	Resistor, 620 ohm, 1/2W, 5%
S1 (START)	604-0470-000 598-0169-000	Switch, Momentary, SPST, N. O. Switch Cap., Red
S2 (STOP)	604-0470-000 598-0171-000	Switch, Momentary, SPST, N. O. Switch Cap., Yellow
S3 (RUN)	604-0470-000 598-0170-000	Switch, Momentary, SPST, N. O. Switch Cap., Green
S4 (HOLD)	604-0470-000 598-0179-000	Switch, Momentary SPST, N. O. Switch Cap., White
S5	914-8507-006 650-0128-000	Switch, Rotary (Modif.) Knob, Black (for S5)

SYMBOL NO.	GATES PART NUMBER	DESCRIPTION
T1	472 0719 000	Transformer, Power
TB1	614 0024 000	Terminal Strip, 2 Term.
TB2	614 0160 000	Terminal Strip, 4 Term.
TB3	614 0149 000	Terminal Strip, 5 Term.
TB4	614 0162 000	Terminal Strip, 6 Term.
U1	382 0143 000	Regulator, Integrated Circuit, 5 V. 5 A, M1VR-42050-055
V101,V102, V201,V202	378 0043 000	Tube, Display
XF1	402 0023 000	Fuseholder (for F1)
XQ1	404 0136 000	Socket, Transistor
XU1	404 0136 000	Socket, Transistor

## 5.2

### SELECTOR MATRIX ASSEMBLY (SSC) (992-3287)

CR1 thru CR10	384 0357 000	Diode, 1N4004
R1,R3, R5,R7, R9,R11, R13,R15, R17,R19 R2,R4, R6,R8, R10,R12, R14,R16, R18,R20	540 0055 000	Resistor, 1.8 K Ohm, 1/2W, 5%
	540 0079 000	Resistor, 18 K Ohm, 1/2W, 5%

## 5.3

### PROGRAM DISPLAY COMPONENT BOARD (SSC) (992-3286)

C101	526 0042 000	Cap., 33 uF, 6V, Tantalum
C102	526 0055 000	Cap., 2.0 uF, 20V, 10% Tantalum
CR101, CR102 CR103, CR104, CR105, CR106	386 0093 000	Diode, Zener, 1N4728A
	384 0357 000	Rectifier, Silicon 1N4004
Q101, Q102, Q103	380 0125 000	Transistor, Silicon NPN, 2N4401

(continued on next page)

SYMBOL NO.	GATES PART NUMBER	DESCRIPTION
R101, R104, R107	540 0912 000	Res., 1 K Ohm, 1/4W, 5%
R102, R103, R105, R106, R108, R109	540 0928 000	Res., 4.7 K Ohm, 1/4W, 5%
U101	382 0083 000	Integrated Circuit, Signetics N7430A
U102	382 0082 000	Integrated Circuit, Signetics N7420A
U103	382 0070 000	Integrated Circuit, Signetics N7400A
U104	382 0077 000	Integrated Circuit, Signetics N8T04B
U106,		
U107	382 0075 000	Integrated Circuit, Signetics N8280A
U105	382 0126 000	Integrated Circuit, TI SN75454P
XV101, XV102	404 0059 000	Socket, Tube
XU101, XU102, XU103, XU106,		
XU107	404 0305 000	Socket, IC, 14 Pin 583-527-1 AMP
XU104	404 0306 000	Socket, IC, 16 Pin 583-529-1 AMP
XU105	404 0308 000	Socket, IC, 8 Pin 583-640-1 AMP

#### 5.4

#### PRESET DISPLAY COMPONENT BOARD (SSC) (992-3335)

C201	526 0042 000	Cap., 33 uF, 6 V, Tantalum
CR201, CR202	386 0093 000	Diode, Zener, 1N4728A
Q201, Q202	380 0125 000	Transistor, Silicon NPN 2N4401
R201, R204	540 0912 000	Res., 1K Ohm, 1/4W, 5%
R202, R203, R205, R206	540 0928 000	Res., 4.7 k Ohm, 1/4W, 5%
U201	382 0083 000	Integrated Circuit, Signetics N7430A
U202	382 0082 000	Integrated Circuit, Signetics N7420A
U203	382 0070 000	Integrated Circuit, Signetics N7400A

(continued on next page)

SYMBOL NO.	GATES PART NUMBER	DESCRIPTION
U204	382 0077 000	Integrated Circuit, Signetics N8T04B
U205	382 0126 000	Integrated Circuit, TI SN75454P
XV201, XV202 XU201, XU202, XU203 XU204 XU205	404 0059 000  404 0305 000 404 0306 000 404 0308 000	Socket, Tube  Socket, IC, 14 Pin 583-527-1 AMP Socket, IC, 16 Pin 583-529-1 AMP Socket, IC, 8 Pin, 583-640-1 AMP

5.5 **NINE-SOURCE EXTENDER (SSCX) MAIN ASSEMBLY (992-3301)**

J15-11 thru J15-19	612 0520 000	Connector, Printed Circuit, 22 Circuit, Single Readout
P1	610 0486 000	Plug, 50 Circuit, P/O Cable
S1	914 8507 006 650 0128 000	Switch, Rotary, 3P11T, Non-Shorting Knob, Black (for S1)

5.6 **CHANNEL MODULE CIRCUIT CARD (992-3552)**

C1,C2	522 0185 000	Cap., 100 uFd, 6 V. Elect.
CR1 thru CR10	384 0357 000	Diode, 1N4004
K1,K2	572 0158 000	Relay, 4 PDT, 24 V, A.E. Co. PD-1400-A18
Q1,Q3	380 0145 000	Transistor, Silicon, PNP, Motorola MPS404A
Q2,Q4	384 0262 000	Rectifier, Silicon, Cont. GE Type C6F
R1,R2	540 0050 000	Res., 1.1 K Ohm, ½ W, 5%
R3,R7	540 0031 000	Res., 180 Ohm, ½ W, 5%
R4,R8	540 0055 000	Res., 1.8 K Ohm, ½ W, 5%
R5,R9	540 0057 000	Res., 2.2 K Ohm, ½ W, 5%
R6,R10	540 0073 000	Res., 10 K Ohm, ½ W, 5%

(continued on next page)

SYMBOL NO.	GATES PART NUMBER	DESCRIPTION
R11,R12	540 0066 000	Res., 5.1 K Ohm, ½ W, 5%
R13	540 0079 000	Res., 18 K Ohm, ½ W, 5%
R14,R16	540 0909 000	Res., 750 Ohm, ¼ W, 5%
R15,R17	540 0907 000	Res., 620 Ohm, ¼ W, 5%

5.7

**CHANNEL MODULE CABLE CONNECTOR ASSEMBLY (992-3290)**

J16(\*)            612 0490 000            Connector, Printed Circuit,  
12 Circuit, Single Readout

\* Corresponds to channel (source) number;  
e.g., J16-4 serves source No. 4.

1143

SYMBOL NO.	GATES PART NUMBER	DESCRIPTION
C1,C7	522 0178 000	Cap., 25 uFd, 6 V, Elect.
C2	500 0807 000	Cap., 18 pF, 500 V, Mica
C3	522 0164 000	Cap., 250 uFd, 3 V, Elect.
C4	522 0242 000	Cap., 25 uFd, 25V, Elect.
C5	522 0376 000	Cap., 1100 uFd, 50 V, Elect.
C6	500 0822 000	Cap., 75 pF, 500 V, Mica
C8	522 0243 000	Cap., 35 uFd, 25V, Elect.
C9	508 0373 000	Cap., .33 uFd, 75 V, paper
C10	522 0505 000	Cap., 220 uFd, 25V, Elect.
C11	516 0043 000	Cap., 470 pF, 1 kV, Disc.
C12	500 0891 000	Cap., 100 pF, 500 V, Mica
Q1,Q2	380 0092 000	Transistor, Silicon NPN, TN323
Q3	380 0042 000	Transistor, Silicon NPN, 2N697
Q4	380 0044 000	Transistor, Silicon PNP, 40319
R1	540 1131 000	Res., 30 K Ohm, 1/2W, 5%, low noise
R2	540 1106 000	Res., 6.2 K Ohm, 1/2W, 5%, low noise
R3	540 1107 000	Res., 20 K Ohm, 1/2W, 5%, low noise
R4	540 1148 000	Res., 75 Ohm, 1/2W, 5%, low noise
R5	540 0042 000	Res., 510 Ohm, 1/2W, 5%
R6	540 0072 000	Res., 9.1 K Ohm, 1/2W, 5%
R7,R11	540 0049 000	Res., 1 K Ohm, 1/2W, 5%
R8	540 0060 000	Res., 3 K Ohm, 1/2W, 5%
R9	540 0045 000	Res., 680 Ohm, 1/2W, 5%
R10	540 1102 000	Res., 100 Ohm, 1/2W, 5%
R12	540 1194 000	Res., 13 K Ohm, 1/2W, 5%
R13	540 1105 000	Res., 5.1 K Ohm, 1/2W, 5%
R14,R15	540 0001 000	Res., 10 Ohm, 1/2W, 5%
R16	540 0018 000	Res., 51 Ohm, 1/2W, 5%
R17	540 0025 000	Res., 100 Ohm, 1/2W, 5%
R18	550 0359 000	Potentiometer, 10 K Ohm
T1	478 0285 000	Transformer, Input
T2	478 0314 000	Transformer, Output
Z1,Z2	414 0087 000	Ferrite Bead

## ALARM CIRCUIT CARD (994-6884)

SYMBOL NO.	GATES PART NUMBER	DESCRIPTION
C1	522 0246 000	Cap., 100 uFd, 25 V, Elect.
C2	522 0233 000	Cap., 2 uFd, 25 V, Elect.
CR1,CR2, CR3	384 0357 000	Diode, 1N4004
K1,K2	574 0210 000	Relay, 4 PDT, 24 V, Parelco R40-E1-Z4-V800
Q1	380 0145 000	Transistor, Silicon PNP Motorola MPS404A
Q2	380 0044 000	Transistor, Silicon PNP RCA 40319
Q3	380 0141 000	Transistor, Unijunction 2N4870
Q4	384 0261 000	Rectifier, Silicon Cont. 2N5061
Q5	380 0143 000	Transistor, Silicon NPN RCA 40311
R1,R5, R10	540 0073 000	Res., 10 K Ohm, ½ W, 5%
R2,R3	540 0063 000	Res., 3.9 K Ohm, ½ W, 5%
R4	540 0055 000	Res., 1.8 K Ohm, ½ W, 5%
R6	550 0392 000	Res., Var, 100 K Ohm, IRC X-201-R 104B or equivalent
R7	540 0035 000	Res., 270 Ohm, ½ W, 5%
R8	540 0013 000	Res., 33 Ohm, ½ W, 5%
R9	540 0071 000	Res., 8.2 K Ohm, ½ W, 5%
XK1,XK2	404 0272 000	Socket, Relay, w/Spring Parelco 9XR40-1

5.10

**KEYSET ASSEMBLY (994-6885)**

<u>SYMBOL NO.</u>	<u>GATES PART NUMBER</u>	<u>DESCRIPTION</u>
	604 0490 000	Pushbutton Keypad, A.E. Co. Type 1200 PD-84970-A
	610 0532 000	Plug, 5 Circuit, Molex 09-56-1052
	610 0533 000	Plug, 8 Circuit, Molex 09-56-1082

1143

## POWER SUPPLY CIRCUIT CARD (992-3281)

SYMBOL NO.	GATES PART NUMBER	DESCRIPTION
C1	522 0376 000	Cap., 1100 uFd, 50 V, Elect.
C2	522 0414 000	Cap., 500 uFd, 50 V, Elect.
C3	522 0429 000	Cap., 2200 uFd, 25 V, Elect.
CR1,CR2, CR6,CR7	384 0357 000	Diode, 1.0 A, 400 P.I.V., 1N4004
CR3,CR4	384 0286 000	Diode, 3.0 A, 200 P.I.V., MOT 1N4721
CR5	386 0156 000	Diode, Zener, 1 W, 24 V, 10% 1N3029A
Q1	380 0066 000	Transistor, Silicon PNP, MOT 2N3740
R1	542 1133 000	Res., WW, 200 Ohm, 5 W.
R2,R3	540 0049 000	Res., 1 K Ohm, ½ W, 5%
R4,R5, R6,R7	540 0025 000	Res., 100 Ohms, ½ W, 5%

## START CONTROL CIRCUIT CARD (992-3777)

SYMBOL NO.	GATES PART NUMBER	DESCRIPTION
C1	522 0232 000	Cap., 1 uFd, 25 V, Elect.
C2	522 0244 000	Cap., 50 uFd, 25 V, Elect.
CR1, CR2, CR5, CR6, CR7, CR8, CR11, CR12	384 0357 000	Diode, 1N4004
CR3	386 0083 000	Diode, Zener, 1N4742A
CR9, CR10	386 0137 000	Diode, Zener, 1N4746A
K1	574 0210 000	Relay, 4PDT, 24V, Parelco R40-E1-Z4-V800
Q1, Q3, Q4, Q6	380 0126 000	Transistor, Silicon NPN, 2N4403
Q2, Q5, Q10, Q11	380 0125 000	Transistor, Silicon NPN, 2N4401
Q7, Q8, Q9	380 0115 000	Transistor, Silicon NPN, 2N5088
Q12	380 0169 000	Transistor, Silicon NPN, 2N5190
R1, R5, R6, R14, R21	540 0055 000	Res., 1.8K Ohm, 1/2W, 5%
R2, R3, R16, R19	540 0080 000	Res., 20K Ohm, 1/2W, 5%
R4, R11	540 0053 000	Res., 1.5K Ohm, 1/2W, 5%
R7, R8, R9, R12, R13, R15, R17, R18,	540 0063 000	Res., 3.9K Ohm, 1/2W, 5%
R20	540 0073 000	Res., 10K Ohm, 1/2W, 5%
R10	540 0332 000	Res., 1K Ohm, 1W, 5%
R22	540 0049 000	Res., 1K Ohm, 1/2W, 5%
R23, R24	540 0031 000	Res., 180 Ohm, 1/2W, 5%
R25	540 0031 000	Res., 180 Ohm, 1/2W, 5%
XK1	404 0272 000	Socket, Relay

## MODE CONTROL CIRCUIT CARD (992-3283)

SYMBOL NO.	GATES PART NUMBER	DESCRIPTION
C1	522 0242 000	Cap., 25 uFd, 25 V, Elect.
C2	522 0185 000	Cap., 100 uFd, 6 V, Elect.
C3	508 0363 000	Cap., .047 uFd, 200 V, Paper
CR1, CR3 thru CR9, CR11 thru CR15	384 0357 000	Diode 1N4004
CR2,CR10	386 0093 000	Diode, Zener, 1N4728A
K1,K3	574 0180 000	Relay, 2 PST, 24 V, A.E. Co. PD-1302-A11A
K2,K4	574 0210 000	Relay, 4 PDT, 24 V, Parelco R40-E1-Z4-V800
Q1,Q4	380 0143 000	Transistor, Silicon NPN, RCA 40311
Q2	384 0261 000	Rectifier, Silicon Cont. 2N5061
Q3,Q5, Q6	380 0145 000	Transistor, Silicon PNP Motorola MPS404A
R1,R8, R9,R15	540 0063 000	Res., 3.9 K Ohm, ½ W, 5%
R2,R6, R11,R14	540 0055 000	Res., 1.8 K Ohm, ½ W, 5%
R3	540 0017 000	Res., 47 Ohm, ½ W, 5%
R4,R7	540 0073 000	Res., 10 K Ohm, ½ W, 5%
R5	540 0031 000	Res., 180 Ohm, ½ W, 5%
R10	540 0057 000	Res., 2.2 K Ohm, ½ W, 5%
R12	540 0080 000	Res., 20 K Ohm, ½ W, 5%
R13	559 0004 000	Thermistor, 10 K Ohm, @ 25° C.
R16	540 0065 000	Res., 4.7 K Ohm, ½ W, 5%
XK2,XK4	404 0272 000	Socket, Relay

## PRESET CONTROL "1-0" CIRCUIT CARD (992-3284)

SYMBOL NO.	GATES PART NUMBER	DESCRIPTION
CR1,CR2, CR3,CR4, CR5	384 0357 000	Diode, 1N4004
Q1 thru Q5	380 0143 000	Transistor, Silicon NPN, RCA 40311
R1,R4, R16, R17	540 0055 000	Res., 1.8 K Ohm, ½ W, 5%
R2,R3, R5 thru R14	540 0063 000	Res., 3.9 K Ohm, ½ W, 5%
R15	540 0051 000	Res., 1.2 K Ohm, ½ W, 5%

Warning, disconnect primary power prior to servicing.

## PRESET CONTROL "01-19" CIRCUIT CARD (992-3357)

SYMBOL NO.	GATES PART NUMBER	DESCRIPTION
C1,C2	526 0042 000	Cap., 33 uF, 100 V Ceramic
CR1 thru CR9, CR11 thru CR22,CR24 thru CR30,CR32 thru CR34	384 0357 000	Diode, 1N4004
CR10,CR23, CR31	386 0081 000	Diode, Zener, 1N4729A
K1	574 0216 000	Relay, Reed, 3PST, N.O. 24 V.
K2	574 0217 000	Relay, Reed, 2PST, N.O. 1PST, N.C. 24 V.
Q1 thru Q11	380 0125 000	Transistor, Silicon, 2N4401
R1,R4, R14,R16, R18,R29, R32	540 0055 000	Res., 1.8K Ohm, $\frac{1}{2}$ W. 5%
R2,R3, R5 thru R13,R30	540 0063 000	Res., 3.9K Ohm, $\frac{1}{2}$ W. 5%
R15,R17	540 0060 000	Res., 3K Ohm, $\frac{1}{2}$ W, 5%
R19 thru R24,R31	540 0073 000	Res., 10K Ohm, $\frac{1}{2}$ W. 5%
R25 thru R28	540 0080 000	Res., 20K Ohm, $\frac{1}{2}$ W. 5%

## PROGRAM RELEASE &amp; SELECTOR CONTROL CIRCUIT CARD (992-3285)

SYMBOL NO.	GATES PART NUMBER	DESCRIPTION
C1	508 0363 000	Cap., .047 uFd, 200 V, Paper
CR1,CR2, CR3,CR5, CR6,CR7, CR8,CR9, CR10,CR11, CR12,CR13, CR14,CR16 CR4,CR15	384 0357 000 386 0093 000	Diode, 1N4004 Diode, Zener, 1N4728A
Q1 thru Q6,Q11 Q7,Q8	380 0143 000 380 0145 000	Transistor, Silicon NPN, RCA 40311 Transistor, Silicon PNP Motorola MPS404A
Q9 Q10	380 0115 000 380 0044 000	Transistor, Silicon NPN, 2N5088 Transistor, Silicon PNP, RCA 40319
R1,R4 R16,R17, R18,R22, R24,R28, R29 R2,R3, R5 thru R14,R19, R20,R26, R27,R30 R15 R21 R23 R25 R31	540 0055 000   540 0063 000 540 0051 000 559 0004 000 540 0080 000 540 0057 000 540 0067 000	Res., 1.8 K Ohm, ½ W, 5%   Res., 3.9 K Ohm, ½ W, 5% Res., 1.2 K Ohm, ½ W, 5% Thermistor, 10 K Ohm, @ 25° C. Res., 20 K Ohm, ½ W, 5% Res., 2.2 K Ohm, ½ W, 5% Res., 5.6 K Ohm, ½ W, 5%

## SCHEMATIC DIAGRAMS

## INDEX

FIGURE	DESCRIPTION	DWG. NO.
6-1	SOURCE CABLE, CRITERION 80, 855, CSU, etc.	827-9795-001
6-2	SOURCE CABLE, CRITERION COMPACT, etc.	827-9796-001
6-3	SOURCE CABLE, NETWORK, STUDIO, etc.	827-9797-001
	SCHEMATIC – SSC CONTROL CIRCUIT	842-7040-002
	SCHEMATIC – SSCX CONTROL CIRCUIT	838-6247-001
	SCHEMATIC – SSC & SSCX AUDIO CONTROL CIRCUIT	842-7041-001
	SCHEMATIC – POWER SUPPLY	838-5630-001
	SCHEMATIC – START CONTROL	838 9211 001
	SCHEMATIC – MODE CONTROL	838-5632-001
	SCHEMATIC – PRESET CONTROL 1–0	838-5633-001
	SCHEMATIC – PROGRAM RELEASE AND SELECTOR CONTROL	848-5634-001
	SCHEMATIC – PROGRAM DISPLAY	838-5635-001
	SCHEMATIC – SELECTOR MATRIX	838-5636-001
	SCHEMATIC – CHANNEL MODULE	838-6425-001
	SCHEMATIC – BOOSTER AMPLIFIER	838-5638-001
	SCHEMATIC – ALARM CIRCUIT	838-5639-001
	SCHEMATIC – PRESET DISPLAY	838-5770-001
	SCHEMATIC – PRESET CONTROL 1–19	838-5956-001

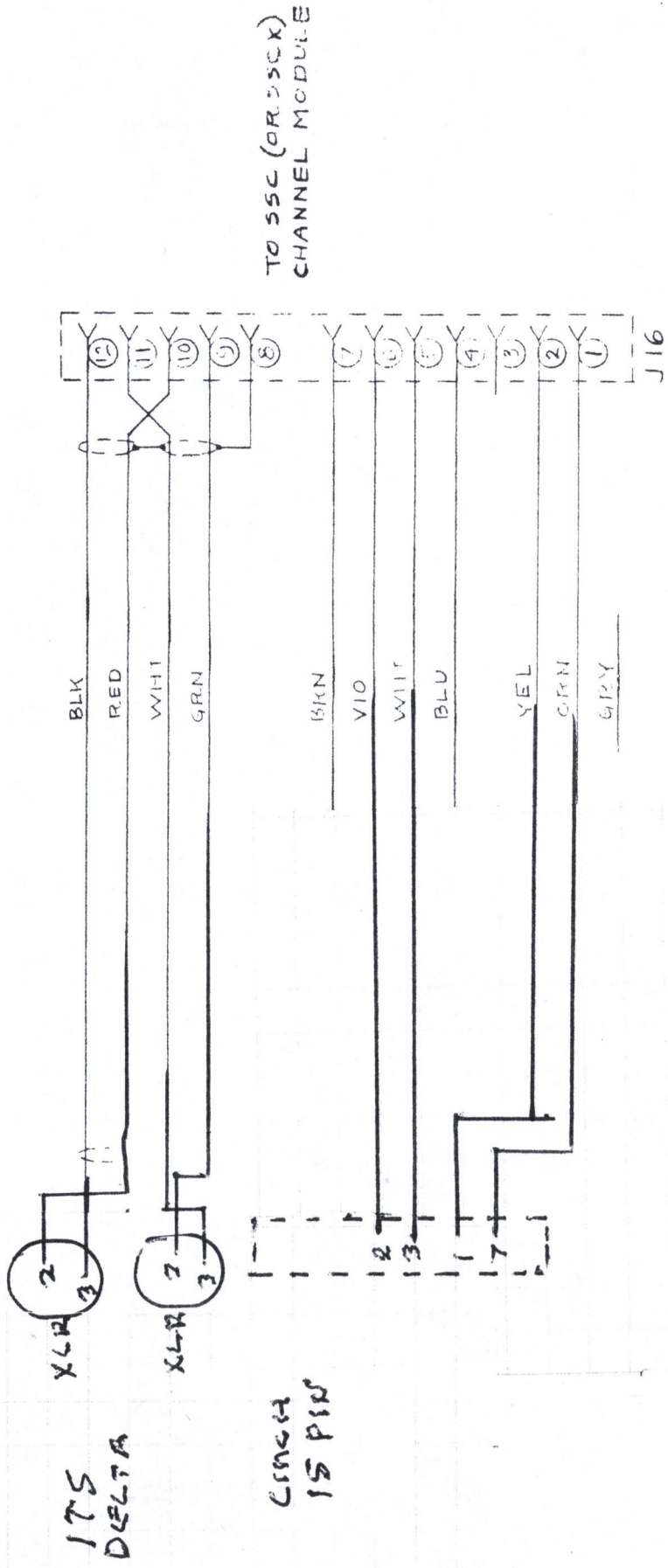

(CINCH 50-12A-20)  
PART OF CHANNEL MODULE  
CABLE CONNECTOR ASSEMBLY  
921-3290-001

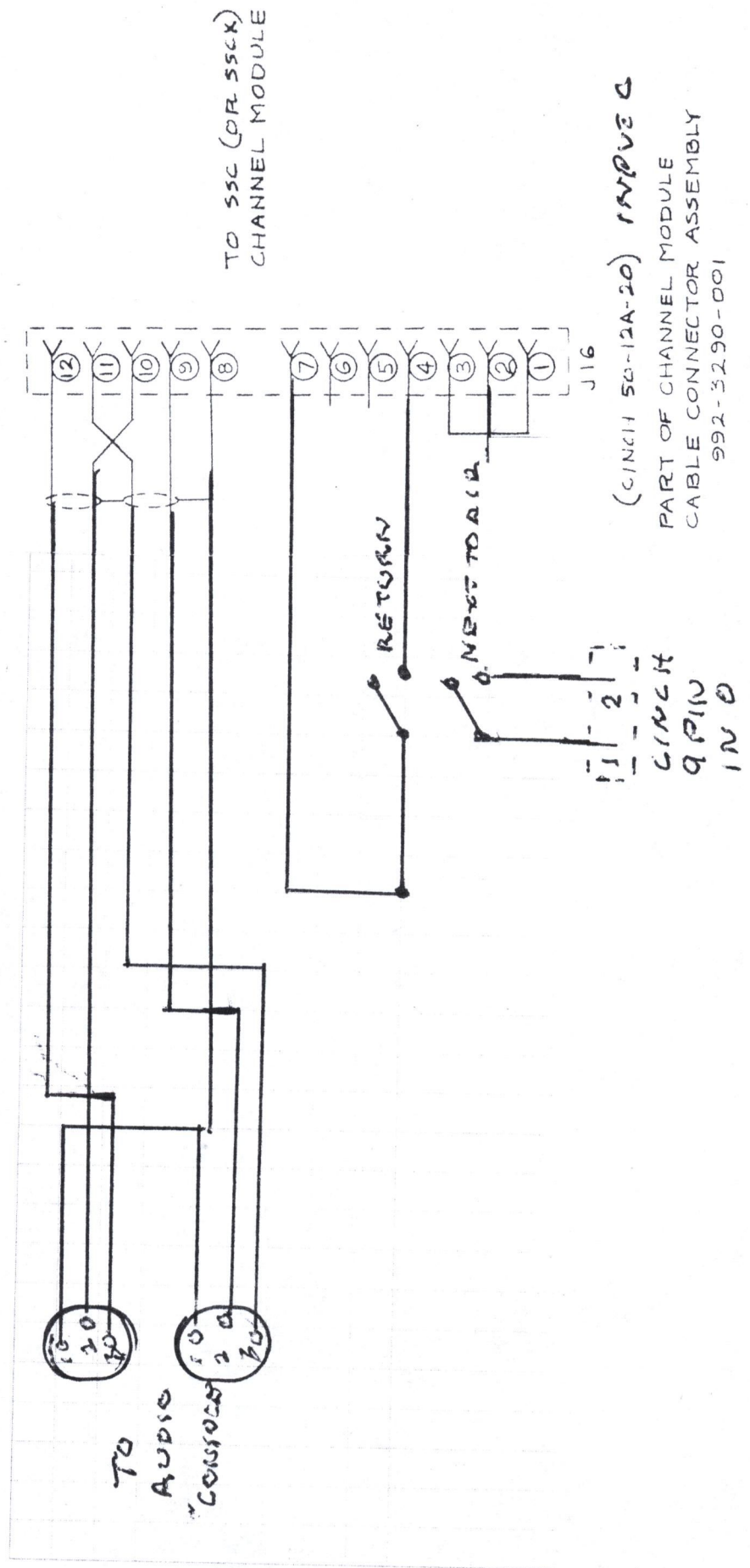

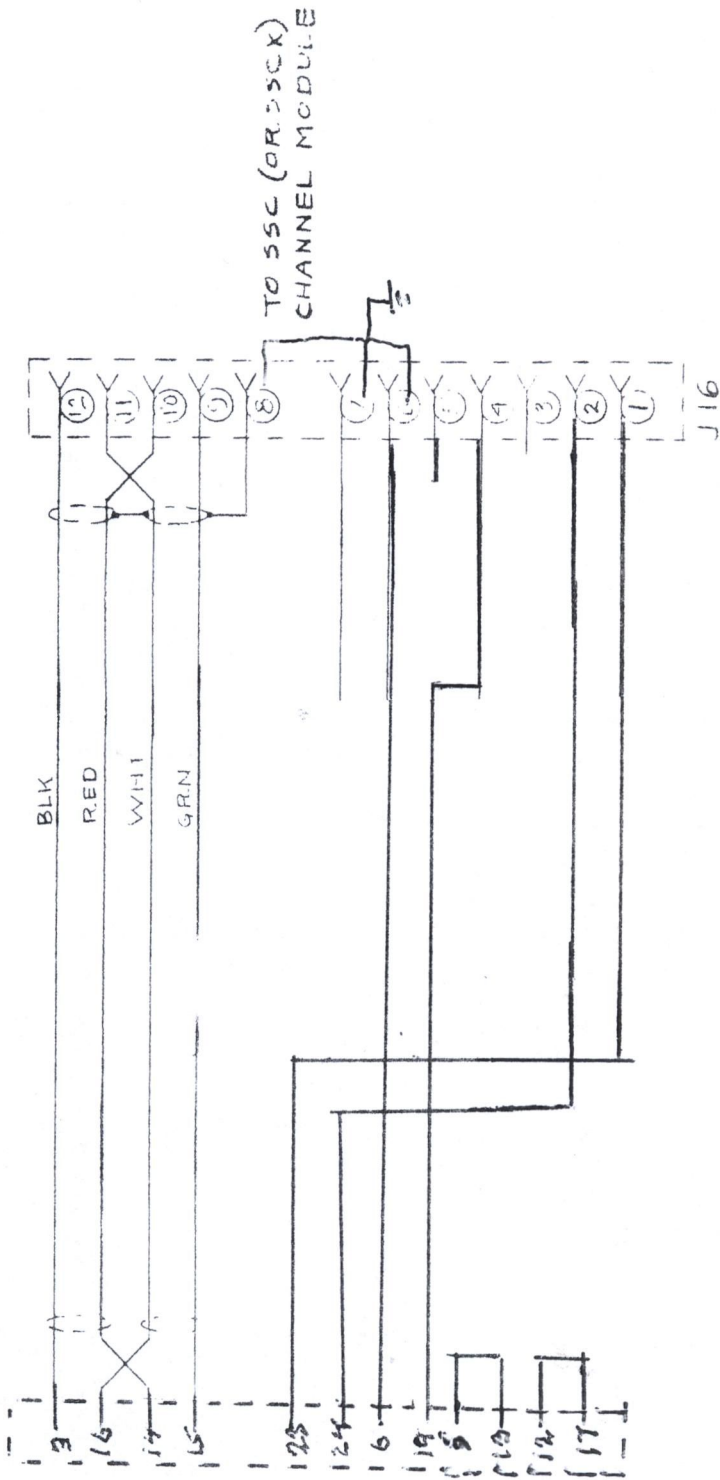

(CINCH 50-12A-20)  
 PART OF CHANNEL MODULE  
 CABLE CONNECTOR ASSEMBLY  
 302 3290-001

CINCH  
 25 PIG

ARS1000  
 PLAY

J16

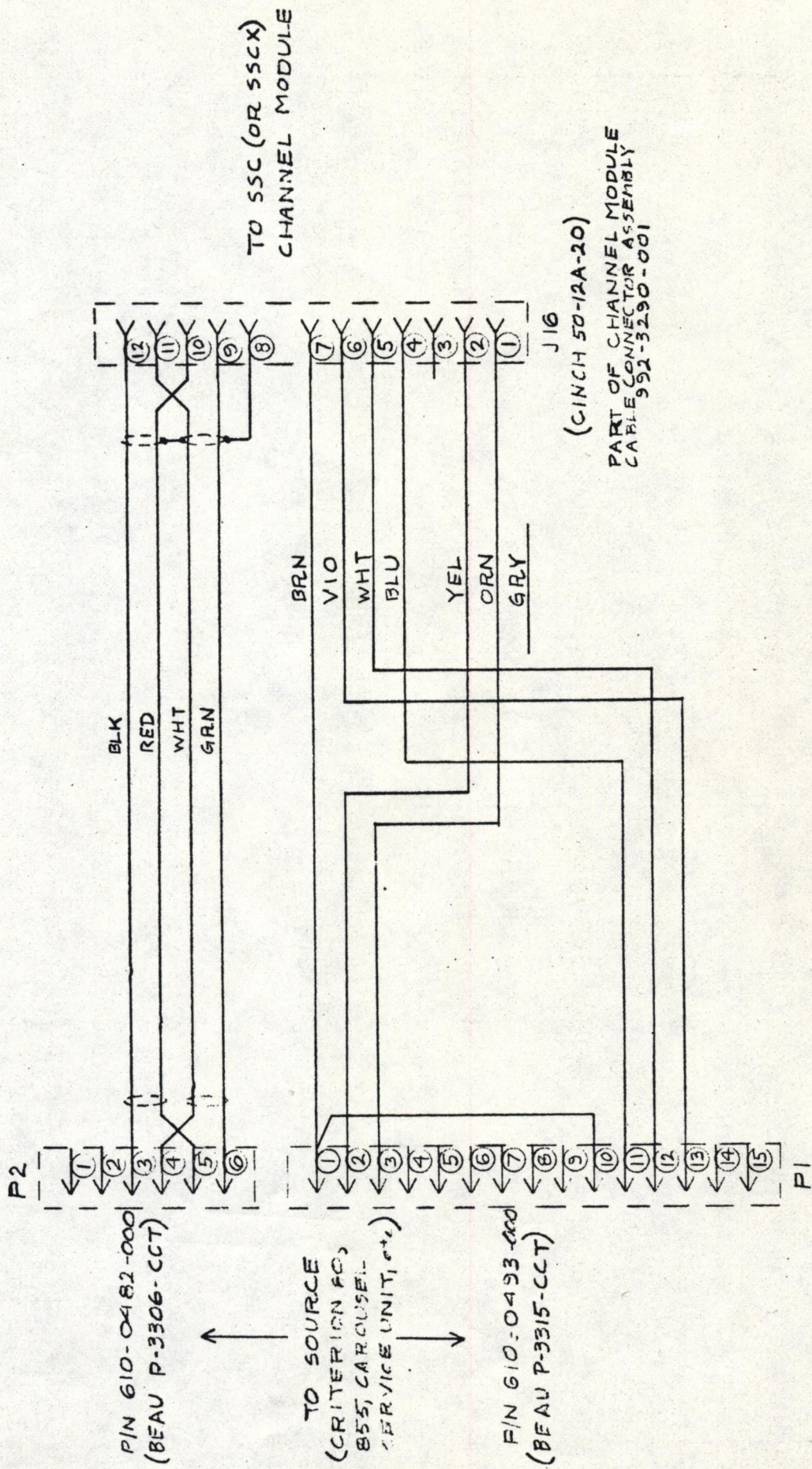

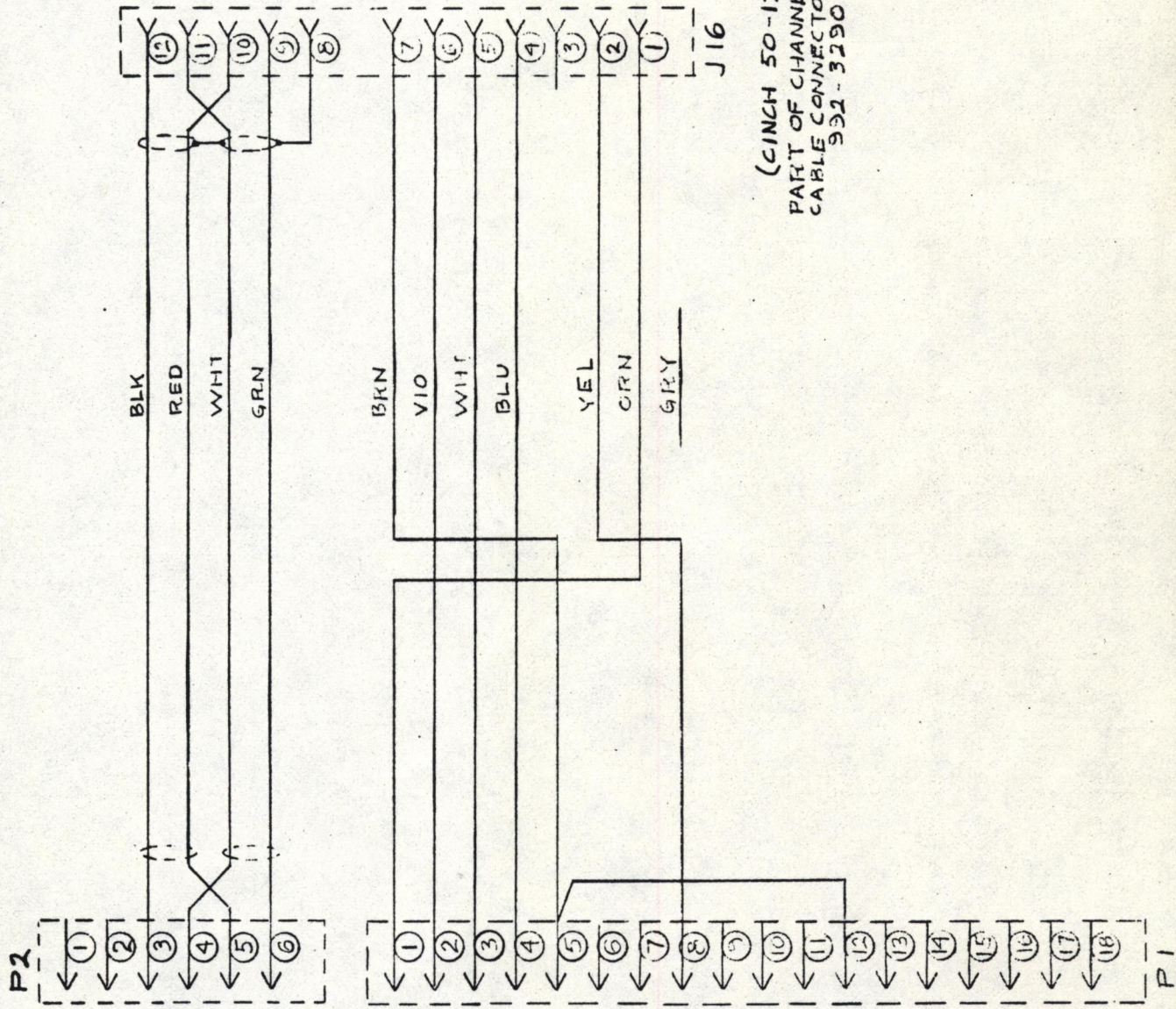

TO SSC (OR SSCX)  
CHANNEL MODULE

(CINCH 50-12A-20)  
PART OF CHANNEL MODULE  
CABLE CONNECTOR ASSEMBLY  
992-3290-001

P/N 610-0482-000  
(BEAU P-33C6-(CT))

TO SOURCE  
(COMPACT OR  
MIDI SERIES)

(BEAU P-3316 (CT))  
P/N 610-0516-000

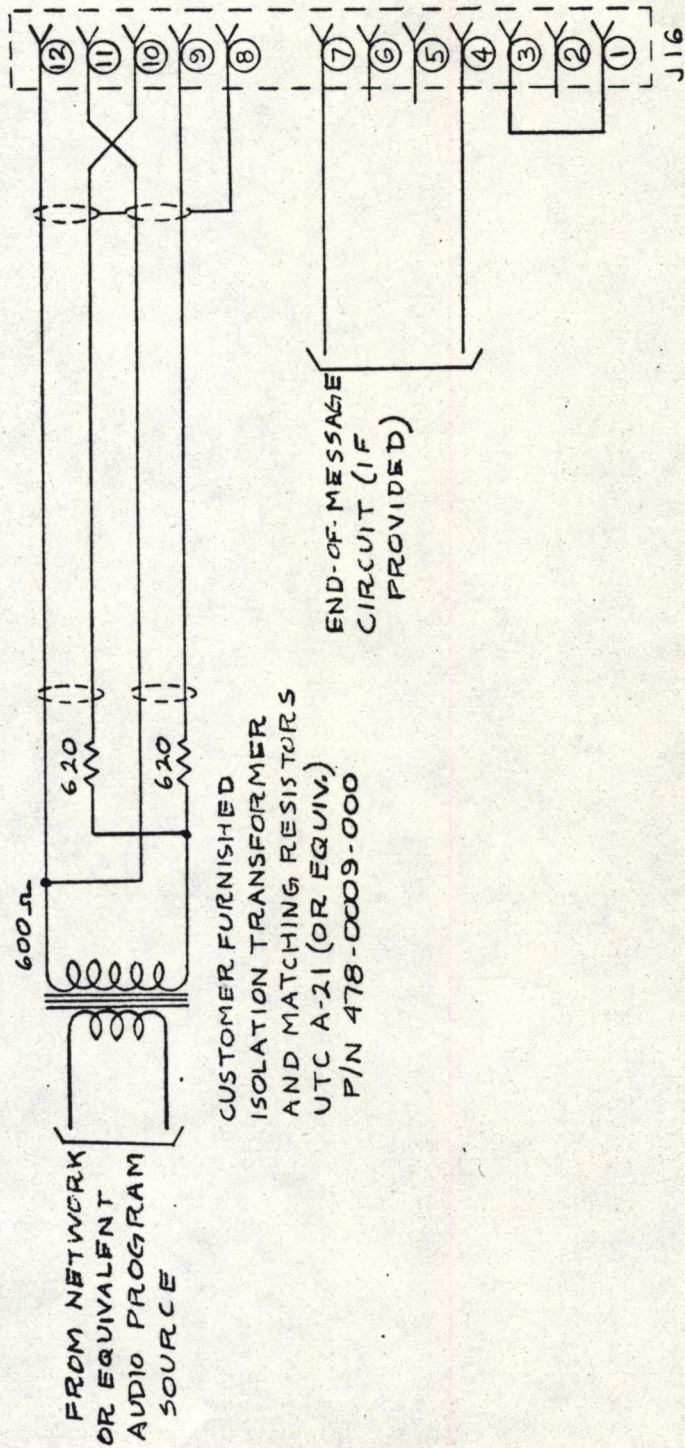

TO SSC (OR SSCX)  
CHANNEL MODULE

(CINCH 50-12A-20)  
PART OF CHANNEL MODULE  
CABLE CONNECTOR ASSEMBLY  
992-3290-001

CUSTOMER FURNISHED  
ISOLATION TRANSFORMER  
AND MATCHING RESISTORS  
UTC A-21 (OR EQUIV.)  
P/N 478-0009-000

FROM NETWORK  
OR EQUIVALENT  
AUDIO PROGRAM  
SOURCE

LTR.	DATE	REVISION	BY	CHK
A	8-72	REVISE PER ECN	W.S.	W.F.
B	1-74	REVISED FOR CLASSIFICATION	W.S.	W.F.
C	9-12	REVISED NUMBERS ON SOME COMPONENTS	W.S.	W.F.

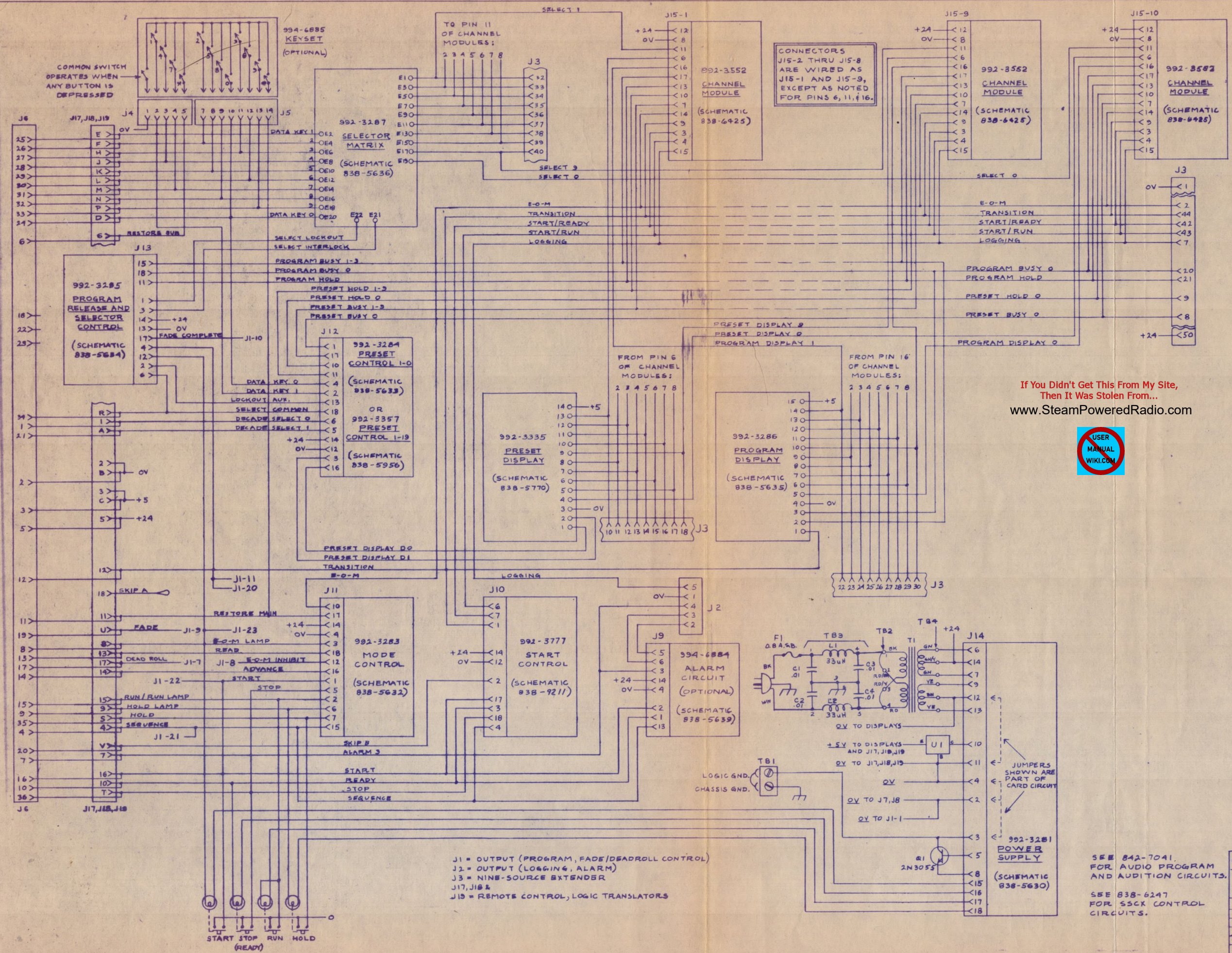

If You Didn't Get This From My Site,  
Then It Was Stolen From...  
[www.SteamPoweredRadio.com](http://www.SteamPoweredRadio.com)



J1 = OUTPUT (PROGRAM, FADE/DEADROLL CONTROL)  
J2 = OUTPUT (LOGGING, ALARM)  
J3 = NINE-SOURCE EXTENDER  
J17, J18 & J19 = REMOTE CONTROL, LOGIC TRANSLATORS

SEE 842-7041 FOR AUDIO PROGRAM AND ADDITION CIRCUITS.  
SEE 838-6247 FOR SSK CONTROL CIRCUITS.

QTY.	PART NO.	ITEM	PART NUMBER	DESCRIPTION
				GATES RADIO COMPANY QUINCY, ILLINOIS
				DATE: 29 AUG 72 BY: W. STEPHENSON MFG: 18 JUN 72
				SCALE: 1:1
				REF. DWG. NO. 842 7040 002

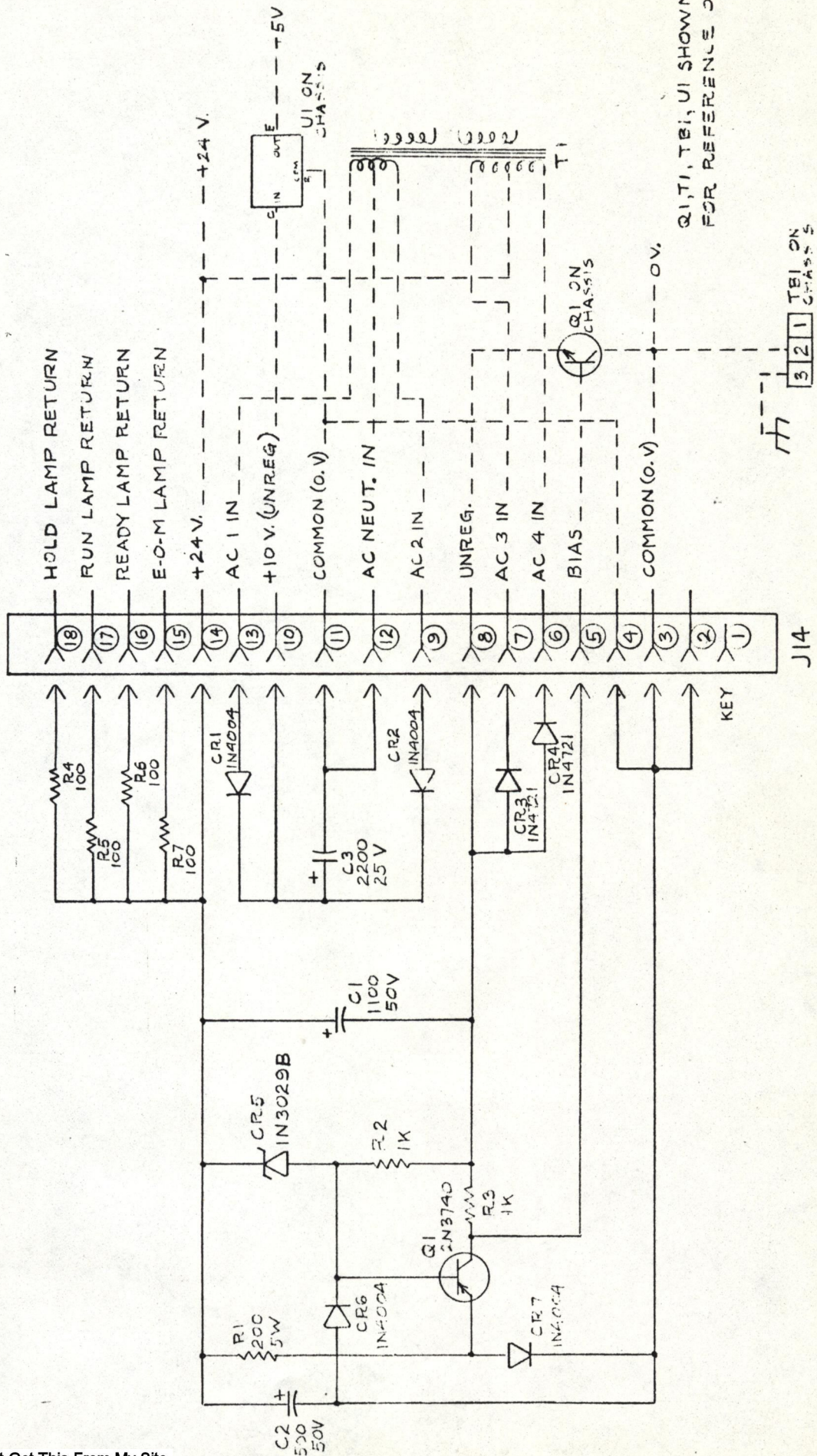

Q1, T1, UI SHOWN FOR REFERENCE ONLY.

If You Didn't Get This From My Site,  
Then It Was Stolen From  
[www.SteamPoweredRadio.com](http://www.SteamPoweredRadio.com)

NO.	DATE	REVISION	DFTM	ENG	ECH
A	2/20/73	J10-6,7 CKTS REVISED			
B	3-27-74	R16 & R19 WERE 3.9K			

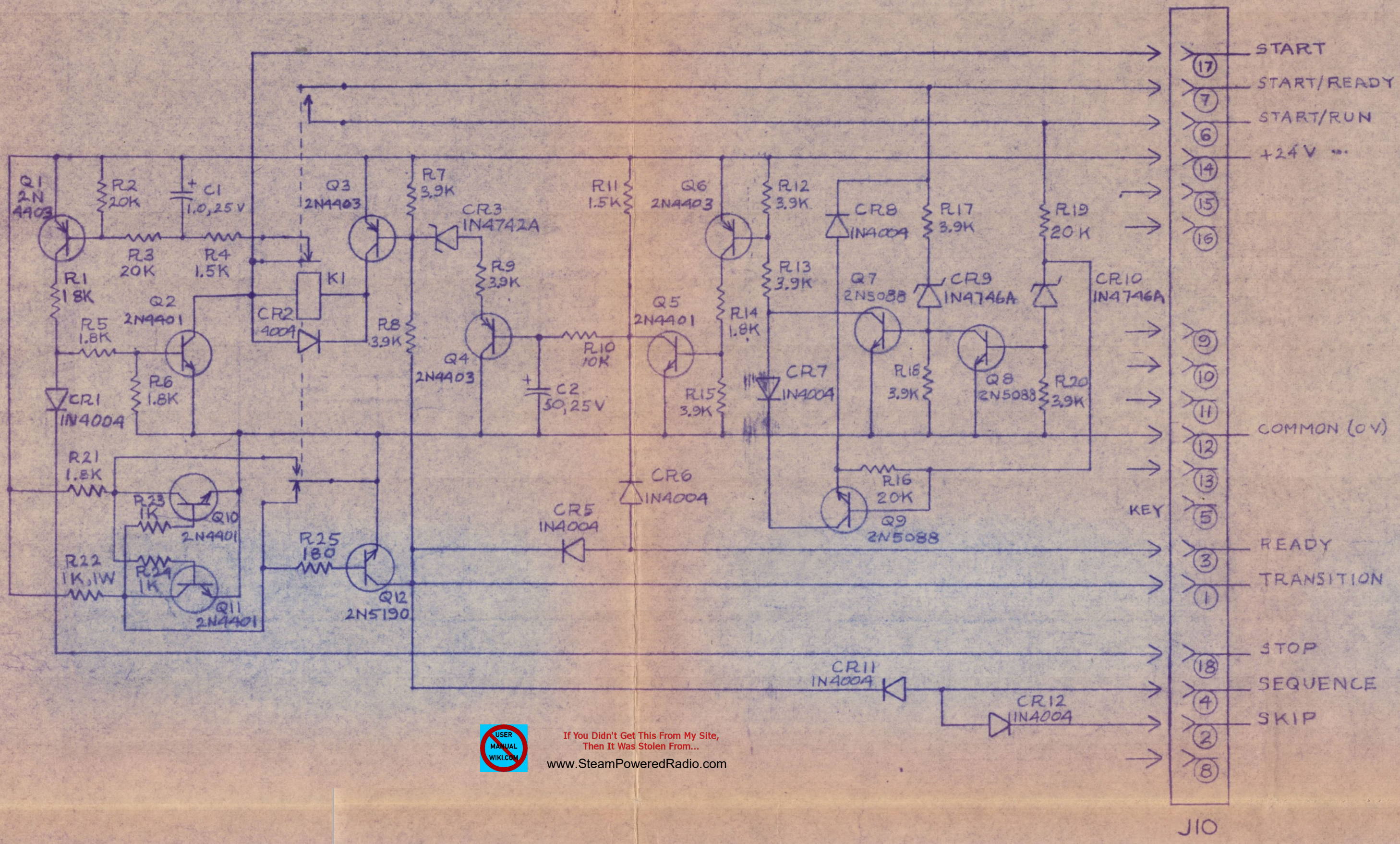

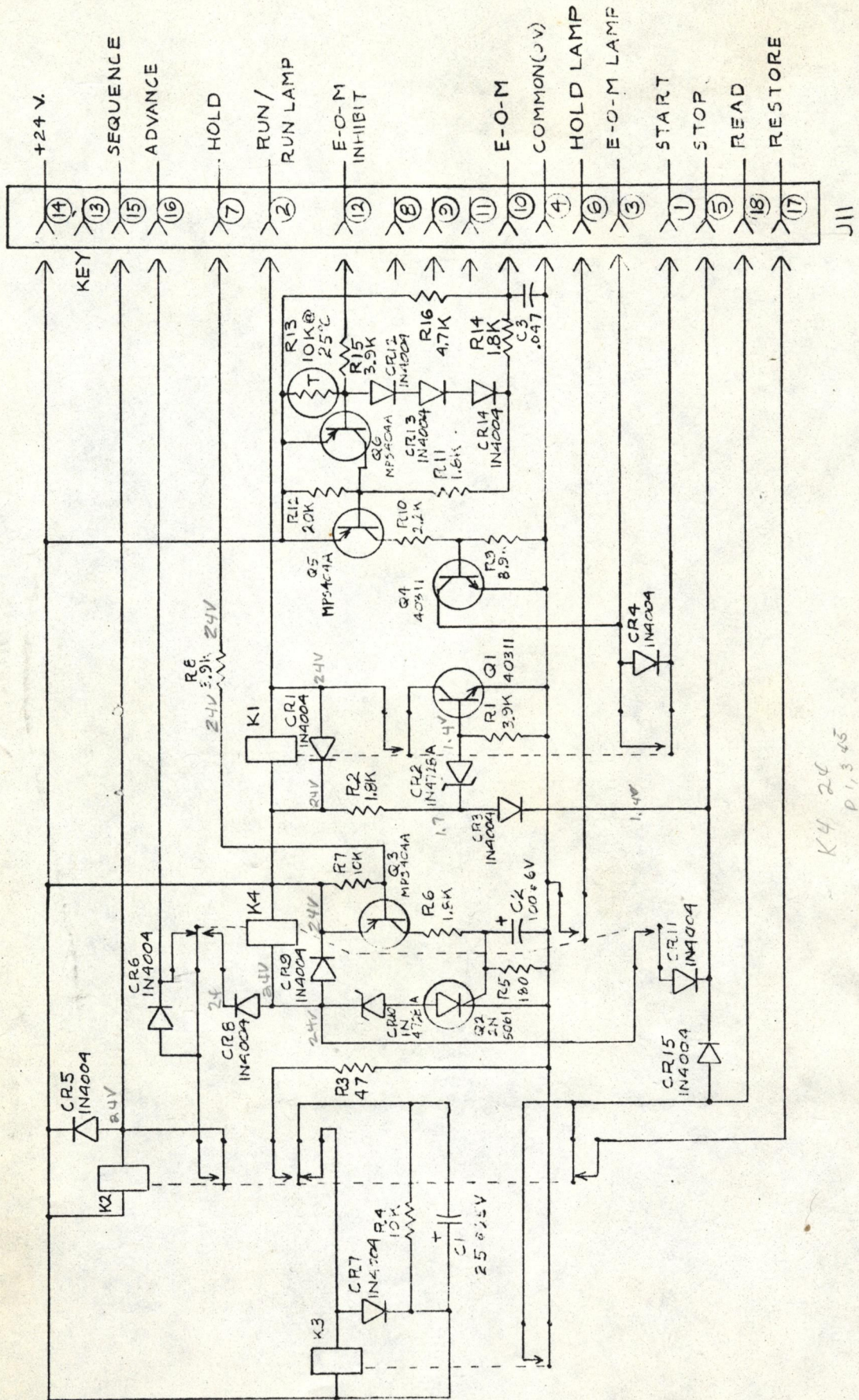

 If You Didn't Get This From My Site,  
 Then It Was Stolen From...  
[www.SteamPoweredRadio.com](http://www.SteamPoweredRadio.com)

QTY.	ITEM	PART NUMBER	DESCRIPTION
<small>TOL. UNLESS NOTED            FRACTIONS ± 1/64            DECIMALS ± .005            ANGLES ± 1°            FOLD DIMENSIONS ± 1/32            ALL VINDICATES 125 MICRO INCH.</small>			<b>GATES RADIO COMPANY</b> QUINCY, ILLINOIS
<small>HARRIS            INTERTYPE            CORPORATION</small>			
<small>6 FEB 73            G.W. STEPHENSON JR.</small>		<b>TITLE START CONTROL            WITH BUFFER</b>	
<small>3/15/73</small>		<b>SYSTEM SWITCHING CENTER</b>	
<small>992-3777-001            USED ON            994-6880-001</small>		<small>FIN.</small>	<small>DWG. NO.            8389211001</small>

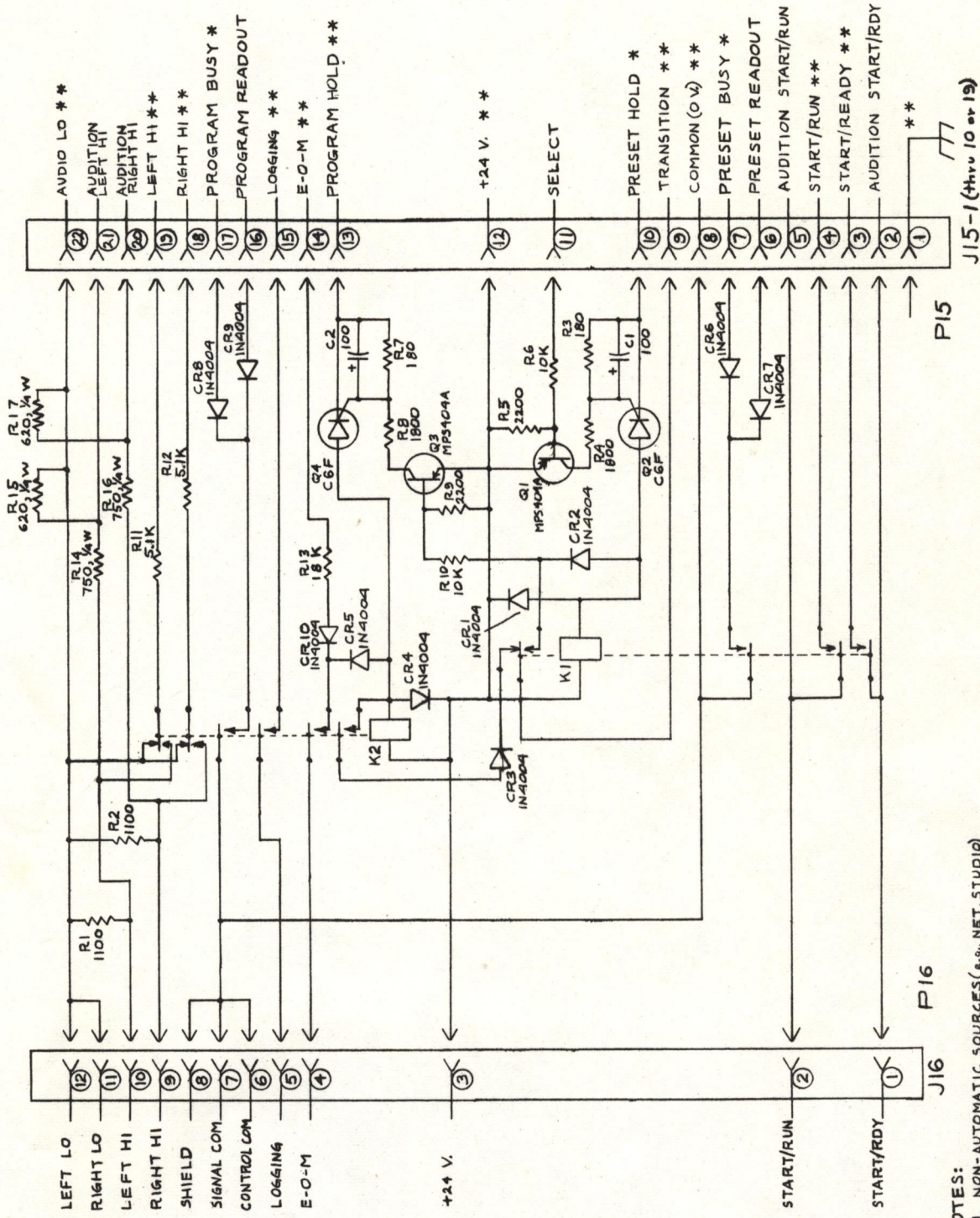

K4 24  
P1,3 45



J15-1 (thru 10 or 19)

NOTES:

1. NON-AUTOMATIC SOURCES (e.g., NET, STUDIO) REQUIRE A STRAP BETWEEN J1-1 AND J1-3 AND NO OTHER CONNECTIONS MAY BE MADE TO J1-1, -2, OR -3. (SEE FIG 6-3)
2. \* DENOTES CIRCUITS COMMON TO ALL CHANNEL MODULES IN A GROUP; e.g., 1-3 or 10-19.
3. \*\* DENOTES CIRCUITS COMMON TO ALL CHANNEL MODULES (01-19).



LTR.	DATE	REVISION	ENG	DFTM	ECN
A	9 SEP 71	REVISED AND REDRAWN	GWS	-	-
B	7-25-74	C101 WAS 0.1	WJH	B	16032

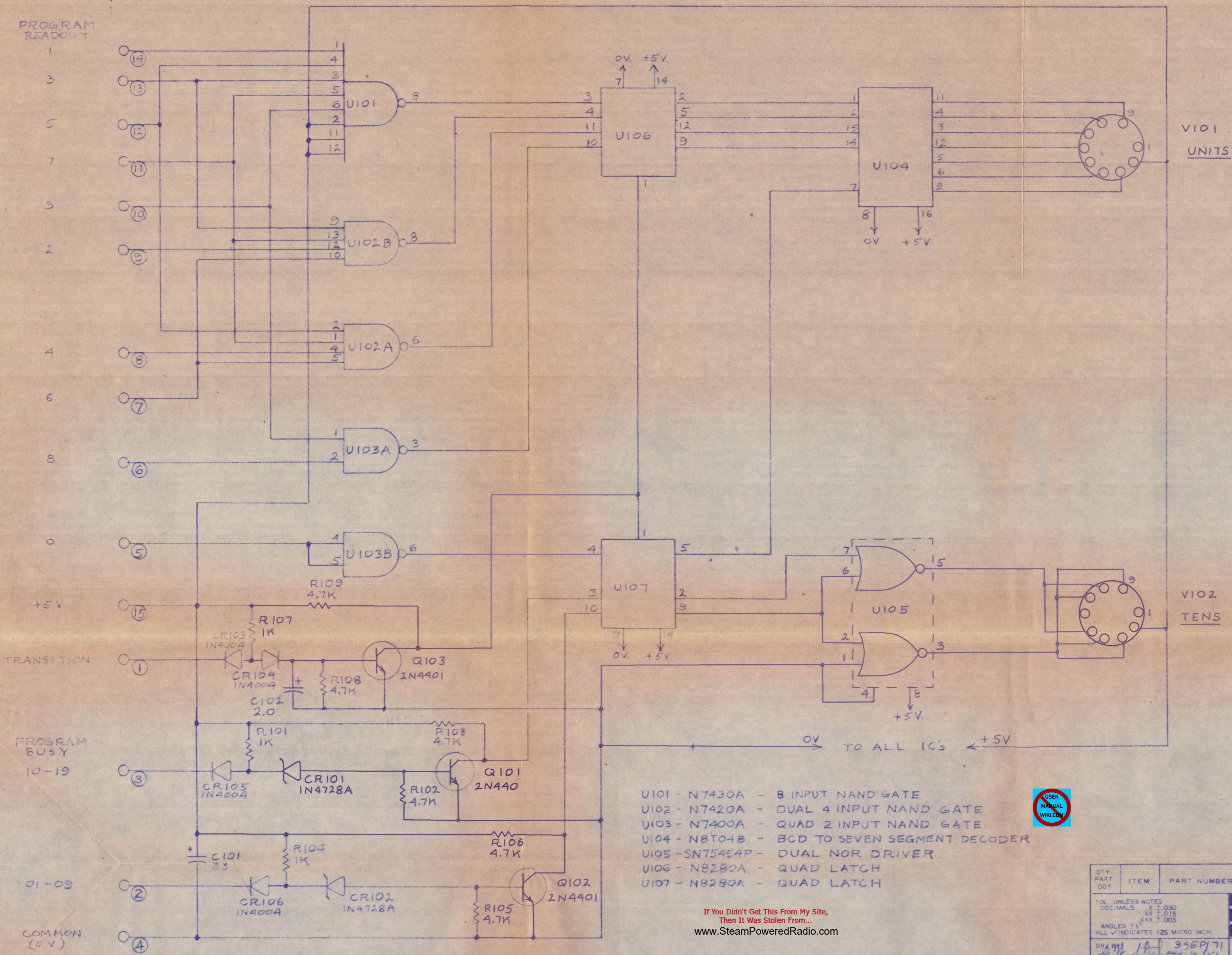

- U101 - N7430A - 8 INPUT NAND GATE
- U102 - N7420A - DUAL 4 INPUT NAND GATE
- U103 - N7400A - QUAD 2 INPUT NAND GATE
- U104 - N8T04B - BCD TO SEVEN SEGMENT DECODER
- U105 - SN75454P - DUAL NOR DRIVER
- U106 - N8280A - QUAD LATCH
- U107 - N8280A - QUAD LATCH



If You Didn't Get This From My Site,  
Then It Was Stolen From...  
[www.SteamPoweredRadio.com](http://www.SteamPoweredRadio.com)

QTY. PART 001	ITEM	PART NUMBER	DESCRIPTION
			<b>HARRIS</b> <b>INTERTYPE</b> <b>CORPORATION</b>
			<b>GATES RADIO COMPANY</b> QUINCY, ILLINOIS
TOL. UNLESS NOTED DECIMALS .X ± .030 .XX ± .015 .XXX ± .005 ANGLES ± 1° ALL ✓ INDICATES 125 MICRO INCH.		TITLE <b>PROGRAM DISPLAY SYSTEM SWITCHING CENTER</b>	
DRA BY <i>WJH</i> 9 SEP 71 CHKD. <i>WJH</i>		REF. DWG. _____ SCALE _____	
M.F.E. _____ PROJ. ENG. <i>WJH</i> 5/19/72 MFG. <i>WJH</i> 5-9-72		DWG. NO. <b>838-5635-001</b>	
NEXT ASSY. <b>992-3286-001</b> USED ON <b>994-6880-001</b>		MAT'L. _____ FIN. _____	

LTR.	DATE	REVISION	DFTM	ECN
4	10/11/72	ADDED U206	SR	
B	1/25/74	C201 WAS 0.1		16032

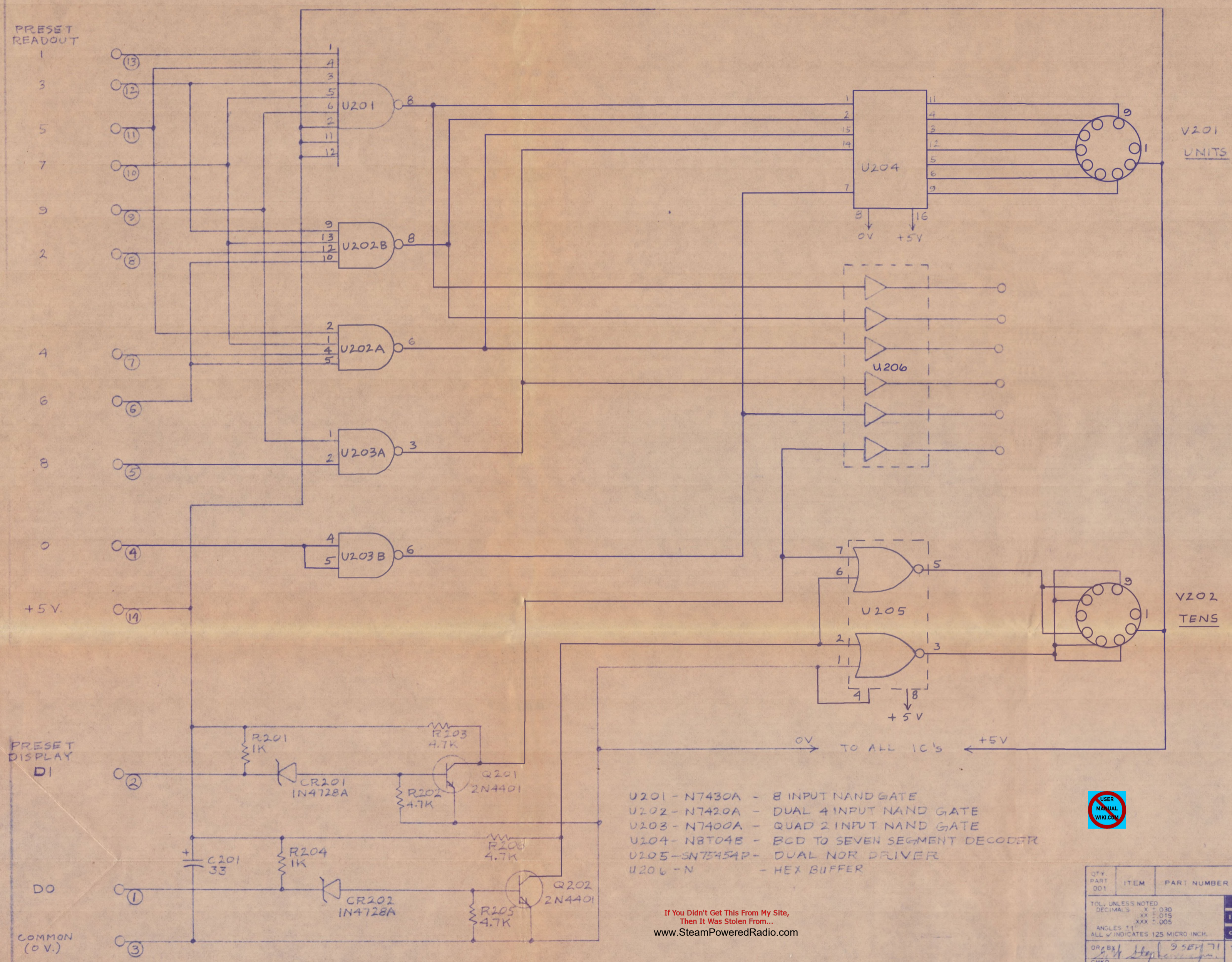

- U201 - N7430A - 8 INPUT NAND GATE
- U202 - N7420A - DUAL 4 INPUT NAND GATE
- U203 - N7400A - QUAD 2 INPUT NAND GATE
- U204 - N8T04B - BCD TO SEVEN SEGMENT DECODER
- U205 - SN75454P - DUAL NOR DRIVER
- U206 - N - HEX BUFFER

If You Didn't Get This From My Site,  
Then It Was Stolen From...  
[www.SteamPoweredRadio.com](http://www.SteamPoweredRadio.com)

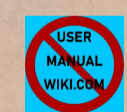

QTY	PART	ITEM	PART NUMBER	DESCRIPTION
TOL. UNLESS NOTED DECIMALS: XX .030 XX .015 XXX .005 ANGLES: 1:1 ALL √ INDICATES 125 MICRO INCH.				<b>HARRIS</b> <b>INTERTYPE</b> <b>CORPORATION</b> <b>GATES RADIO COMPANY</b> <b>QUINCY, ILLINOIS</b>
DR. BY: [Signature] 9 SEP 71 CHKD: [Signature] M.E. PRO. BY: [Signature] 5/9/72 MFG. [Signature] 5-9-72				TITLE <b>PRESET DISPLAY SYSTEM SWITCHING CENTER</b>
NEXT ASSY			REF. DWG.	SCALE
392-3335-001 USED ON 391-6860-001			MAT'L.	FIN.
			DWG. NO.	658-5770-001

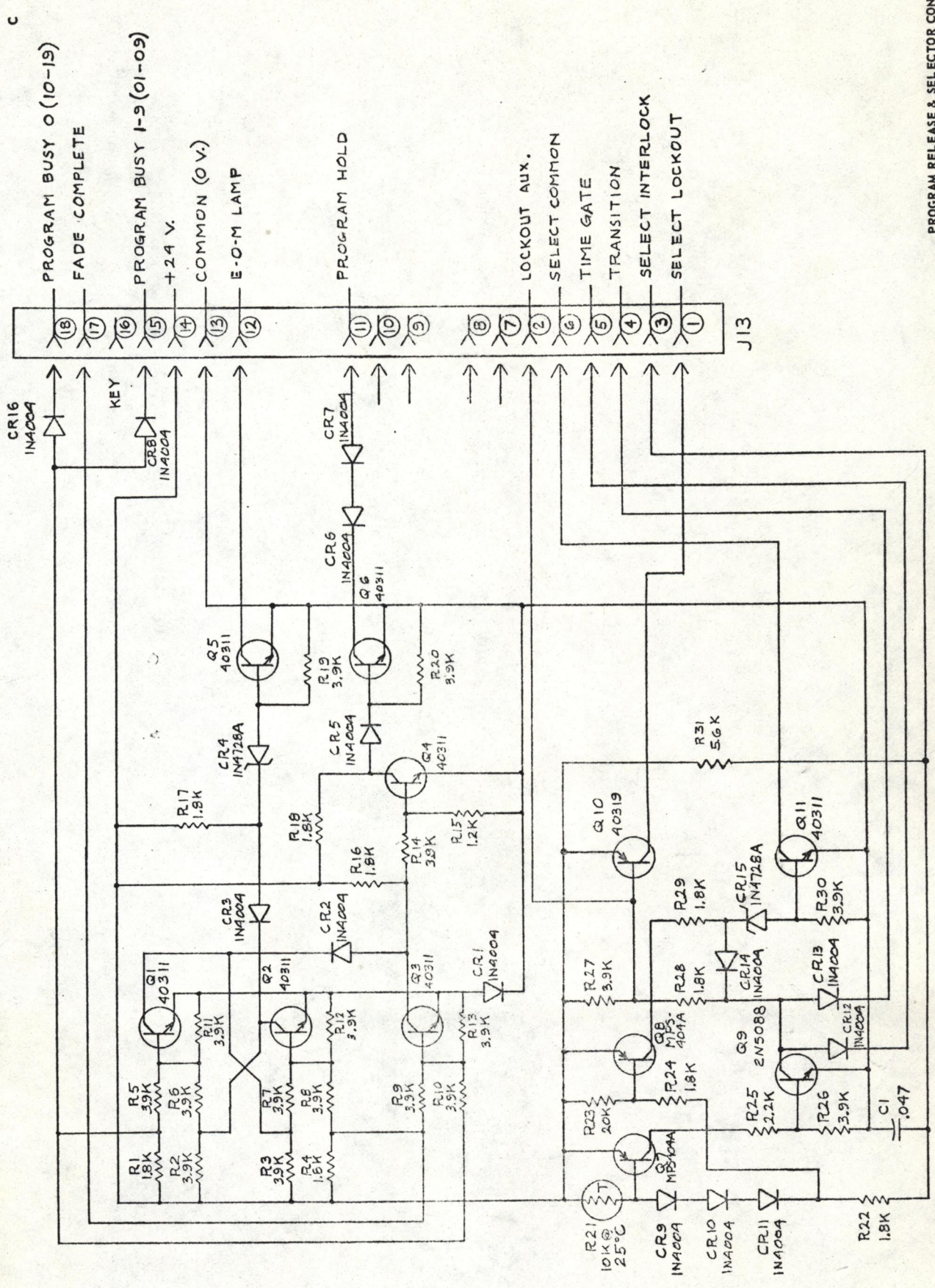

If You Didn't Get This From My Site,  
Then It Was Stolen From  
www.SteamPoweredRadio.com

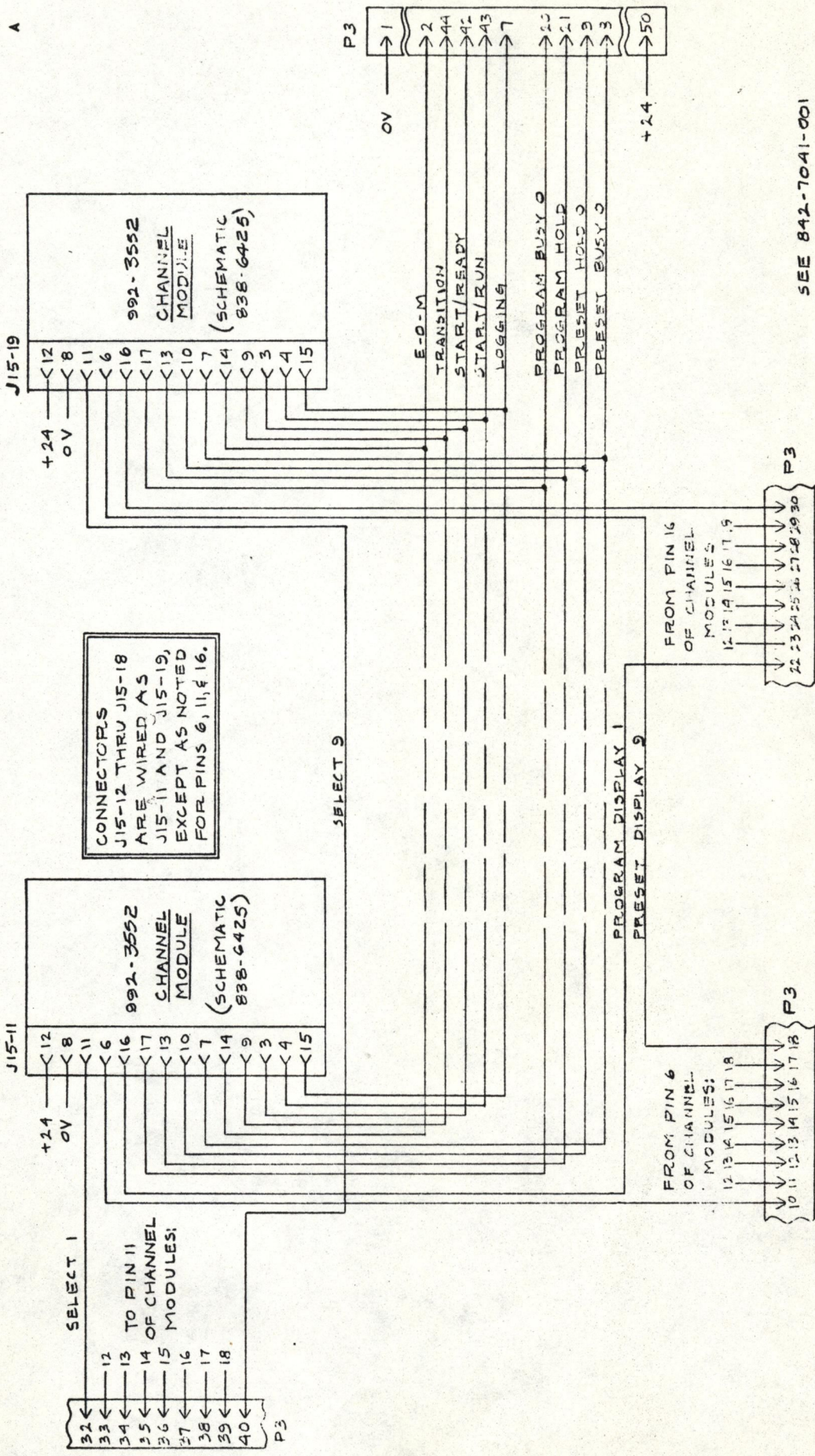

SEE 842-7041-001  
 FOR AUDIO PROGRAM  
 AND ADDITION CIRCUITS.

SEE 842-7040-001  
 FOR SSC CONTROL  
 CIRCUITS.

P3 = TO SYSTEM SWITCHING  
 CENTER, J3

CONTROL CIRCUIT  
 NINE-SOURCE EXTENDER  
 (SSCX)  
 838 6247 001

GATES RADIO COMPANY - QUINCY, ILLINOIS  
 A DIVISION OF HARRIS-INTERTYPE CORPORATION

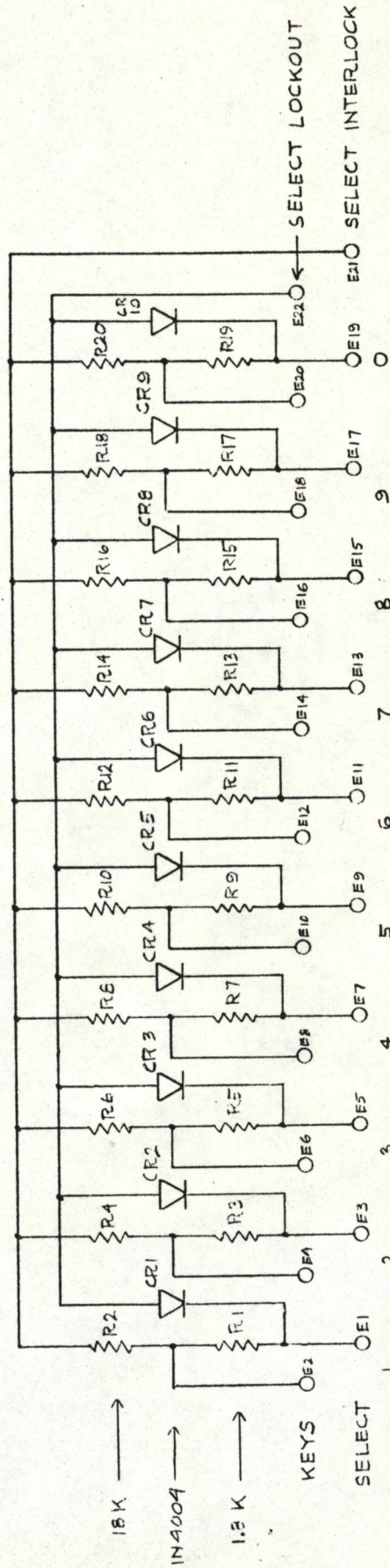

18 K →  
 IN4004 →  
 1.5 K →  
 KEYS  
 SELECT

If You Didn't Get This From My Site,  
 Then It Was Stolen From  
[www.SteamPoweredRadio.com](http://www.SteamPoweredRadio.com)

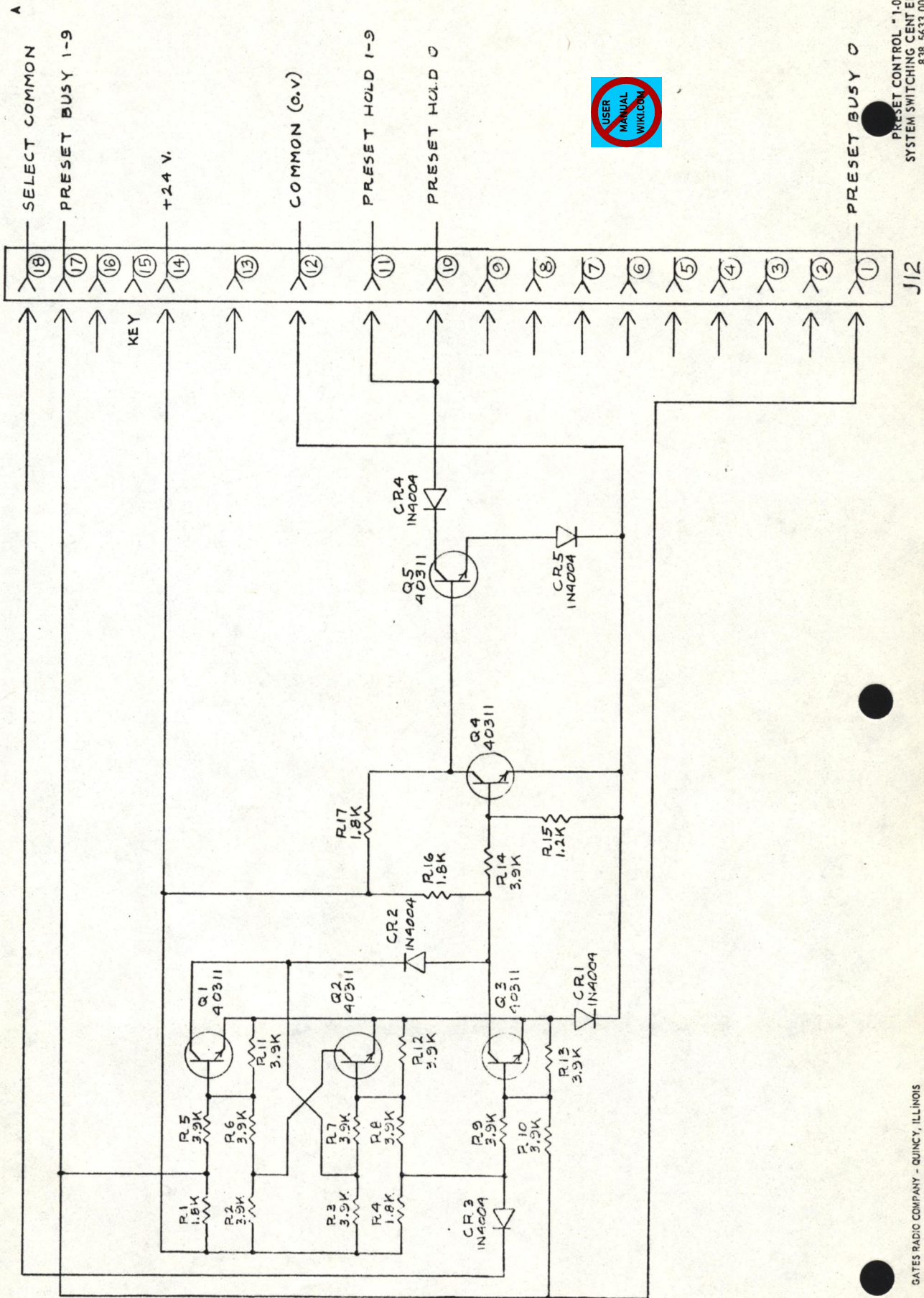

NO	DATE	REVISION	DFTM	ENG	ECH
A	3/27/72	CR31 REVERSED, CR34 ADDED			14077
B	3/27/72	CHG VALUE C1 & C2			14798
C	4/3/73	CR10 WAS IN4004 CR23, CR31 WERE IN4728A			15128



If You Didn't Get This From My Site,  
Then It Was Stolen From...  
www.SteamPoweredRadio.com

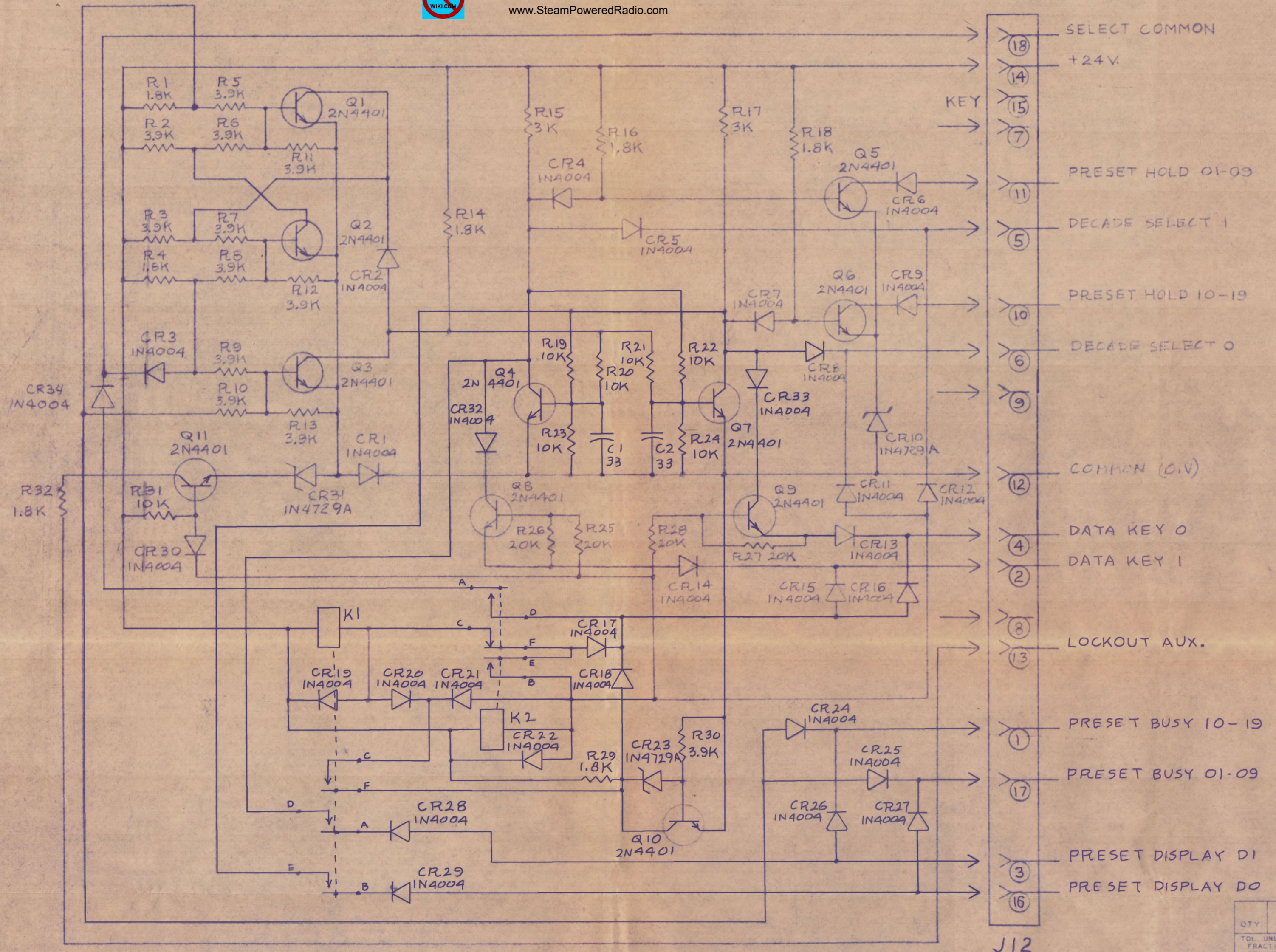

J12

QTY	ITEM	PART NUMBER	DESCRIPTION
			<b>GATES RADIO COMPANY</b> QUINCY, ILLINOIS
			TITLE PRESET CONTROL "1-19" SYSTEM SWITCHING CENTER
			SCALE
992-3357-001		MATL.	FIN.
994-6881-001		DWG. NO. 838-5956-001	

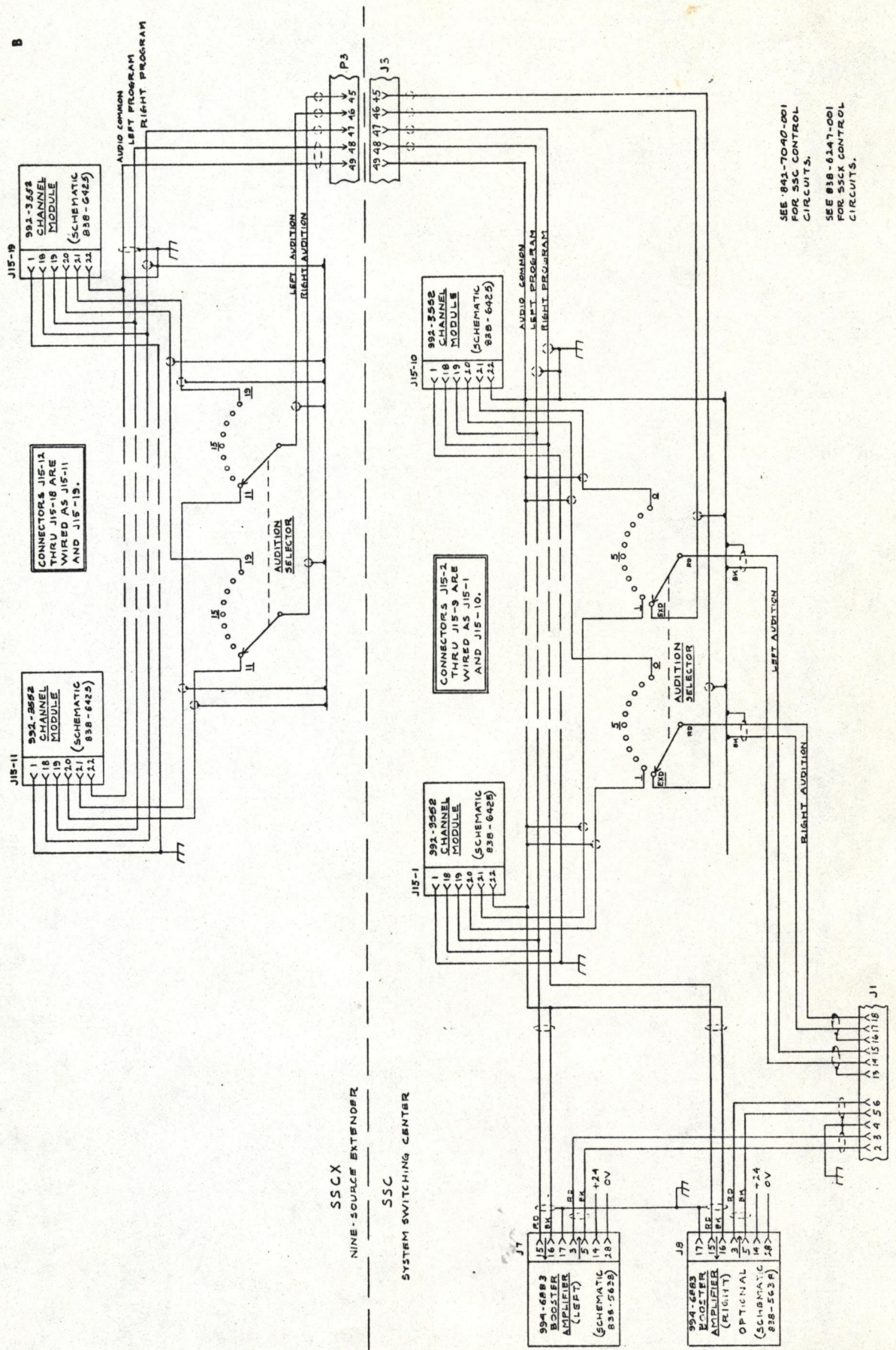

SEE 842-7040-001  
FOR SSC CONTROL  
CIRCUITS.

SEE 838-6247-001  
FOR SSCX CONTROL  
CIRCUITS.

AUDIO CIRCUITS  
SYSTEM SWITCHING CENTER  
AND NINE-SOURCE EXTENDER  
842 7041 001

GATES RADIO COMPANY - QUINCY, ILLINOIS  
A DIVISION OF HARRIS-INTERTYPE CORPORATION

If You Didn't Get This From My Site,  
Then It Was Stolen From  
www.SteamPoweredRadio.com

NO	DATE	REVISION	DFTM	ENG	ECN
A	8-25-71	C11 ADDED			
B	3/17/72	C12 ADDED			
C	9-27-72	C16 VALUE P4-C9-R12			
D	4-7-74	C10 WAS 250UF			

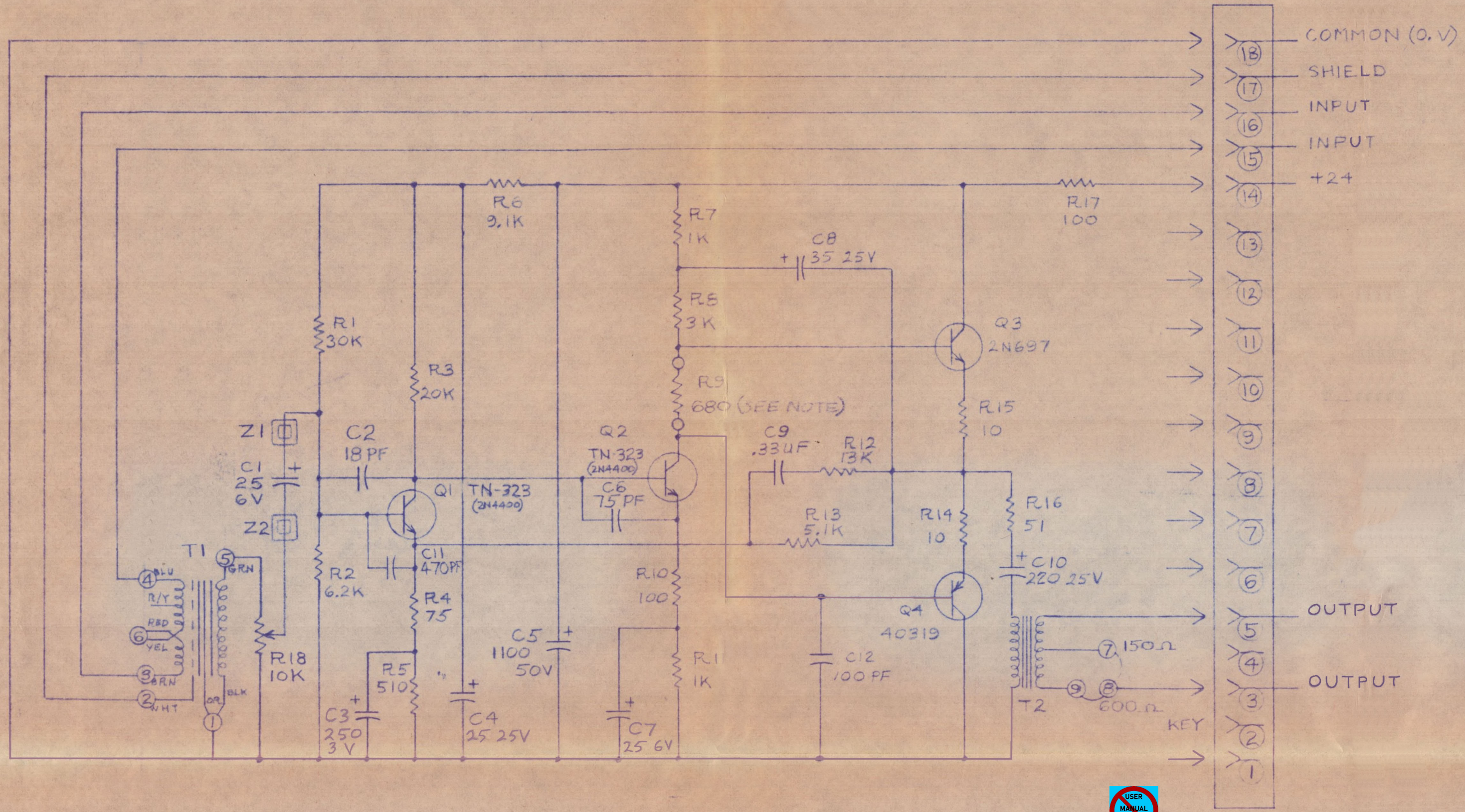

If You Didn't Get This From My Site,  
Then It Was Stolen From...  
www.SteamPoweredRadio.com



J7 (LEFT)  
J8 (RIGHT)

NOTE: R9 SELECTED IN TEST. FINAL VALUE MAY DIFFER FROM VALUE SHOWN.

QTY	ITEM	PART NUMBER	DESCRIPTION
TOL. UNLESS NOTED FRACTIONS ± 1/64 DECIMALS ± .005 ANGLES ± 1° FOLDED DIMENSION ± 1/32" ALL DIMENSIONS 125 MICRO INCH.			<b>HARRIS</b> <b>INTERTYPE</b> <b>CORPORATION</b> <b>GATES RADIO COMPANY</b> QUINCY, ILLINOIS
DR. BY: <i>[Signature]</i> 30 JUN 71 CHKD.: M.E.: PROJ. ENGR: <i>[Signature]</i> 30 JUN 71 NEG. <i>[Signature]</i> 5-9-72			
TITLE: <b>BOOSTER AMPLIFIER SYSTEM SWITCHING CENTER</b>			SCALE:
DWG. NO. <b>838 5638 001</b>			FIN.

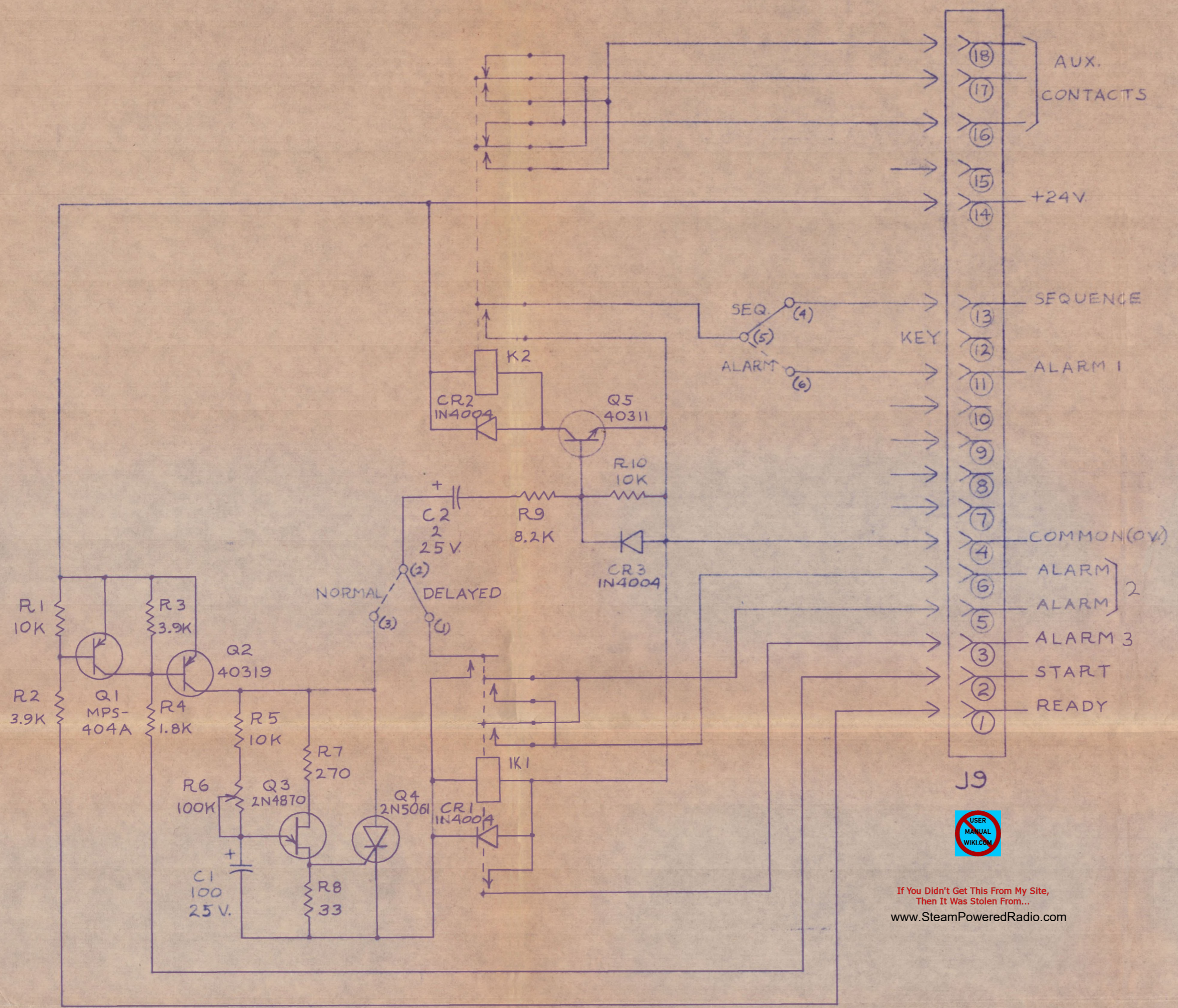

If You Didn't Get This From My Site,  
Then It Was Stolen From...  
[www.SteamPoweredRadio.com](http://www.SteamPoweredRadio.com)

QTY	ITEM	PART NUMBER	DESCRIPTION
TOL. UNLESS NOTED FRACTIONS ± 1/64 DECIMALS ± .005 ANGLES ± 1° FOLD DIMENSIONS ± 1/32 ALL DIMENSIONS UNLESS OTHERWISE SPECIFIED			<b>HARRIS</b> <b>INTERTYPE</b> <b>GATES RADIO COMPANY</b> <b>QUINCY, ILLINOIS</b>
DFTM: 29 JUN 71 PROJ. ENG: [Signature] MFG: [Signature]			
TITLE <b>ALARM CIRCUITS</b> <b>SYSTEM SWITCHING CENTER</b>			SCALE DWG. NO. <b>838 5639 001</b>
NEXT ASSY: 994-6884-001 USER ON:			



---

**HARRIS CORPORATION** Gates Broadcast Equipment Division  
123 Hampshire Street, Quincy, Illinois 62301