

Technics by Panasonic

DIRECT DRIVE TURNTABLE
WITH QUARTZ PHASE LOCKED CONTROL



SP-10MKII

OPERATING INSTRUCTIONS



Read these instructions completely, before operating this set.

If You Didn't Get This From My Site,
Then It Was Stolen From...

www.SteamPoweredRadio.Com

A unique turntable which sets the standard for **DIRECT DRIVE TURNTABLES!**

Thank you for buying the SP-10MKII direct-drive turntable. While following the original design of the SP-10 which was introduced to the audio world in June 1969 the performance of the SP-10MKII has been further perfected. The excellent performance and reliability of the SP-10 are widely recognized now and it is being used by a large number of the world's professional broadcasters. In developing the SP-10MKII we sought performance surpassing even the maximum retrievable sound from a record. The know-how obtained in the development of the SP-10 and suggestions from professional and general users resulted in the superior performance design of the SP-10MKII by meeting the most critical demands of professionals and audiophiles alike who desire quality sound in their appreciation of music.

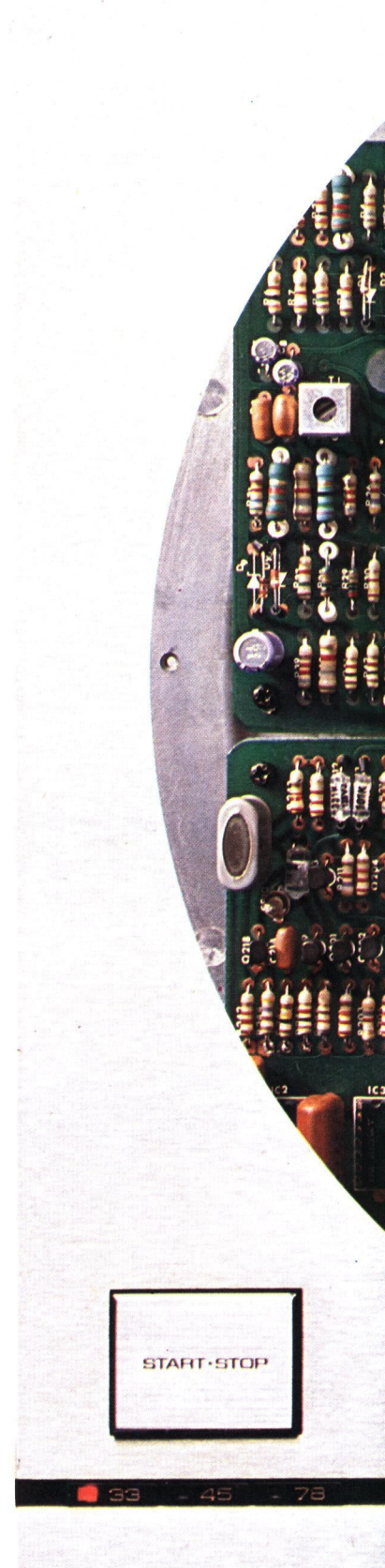

“WARNING: TO PREVENT FIRE OR SHOCK HAZARD, DO NOT EXPOSE THIS APPLIANCE TO RAIN OR MOISTURE.”

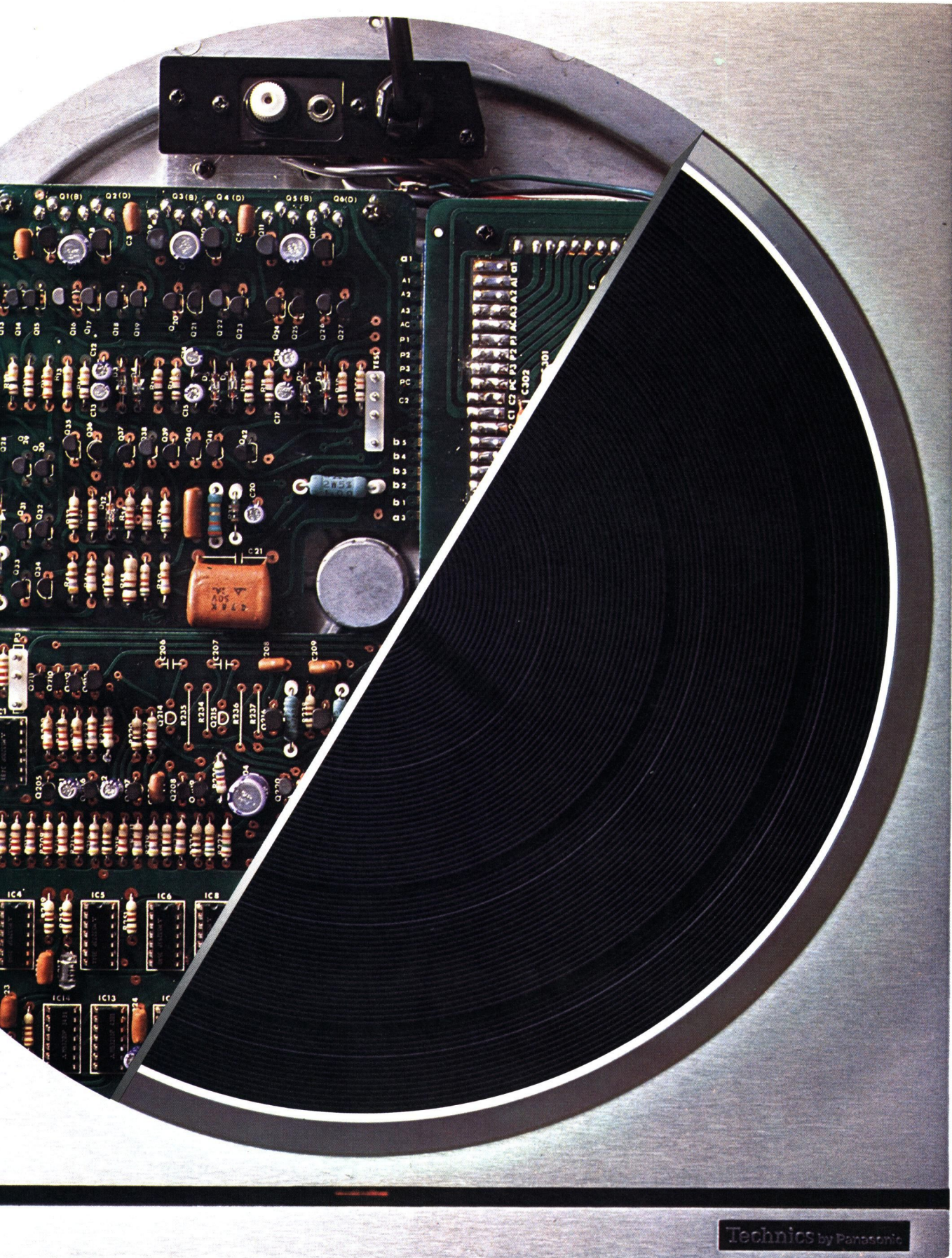

PARTS IDENTIFICATION

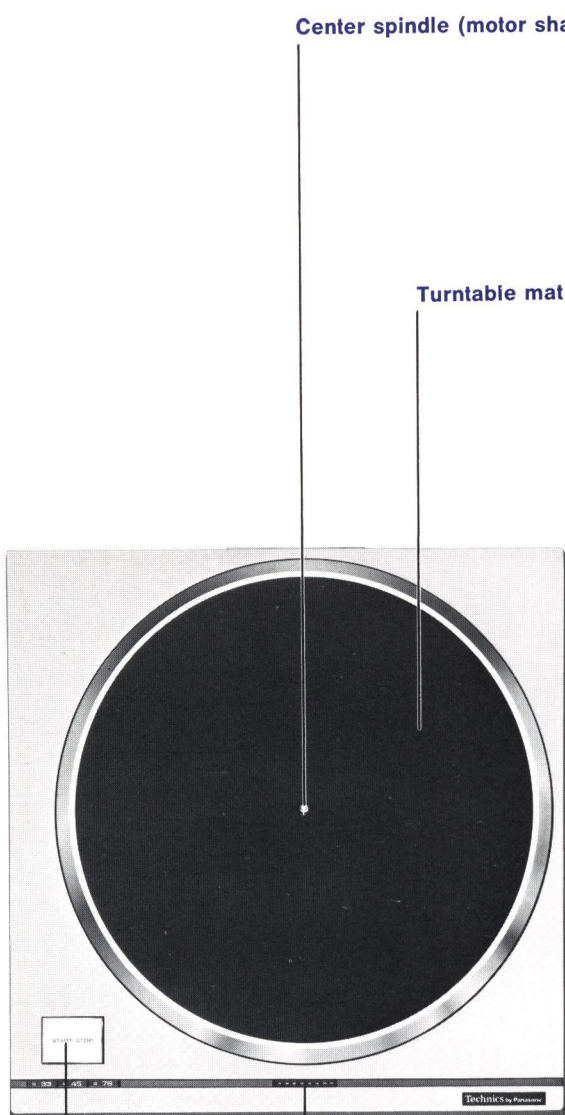

Center spindle (motor shaft)

Turntable mat

Start/stop switch

Stroboscope

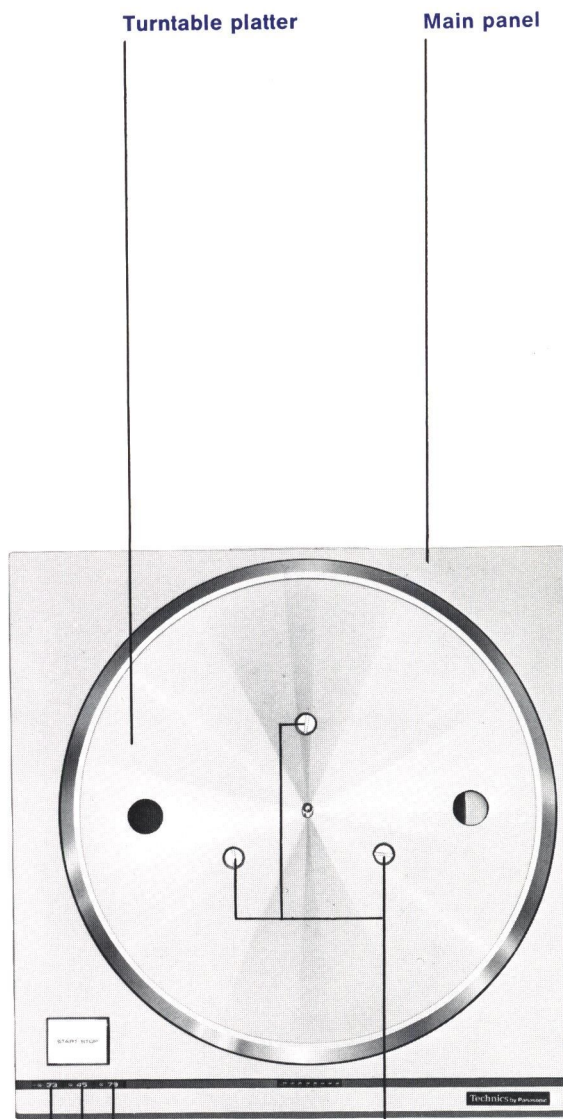

Turntable platter

Main panel

Speed selectors

Turntable platter screws

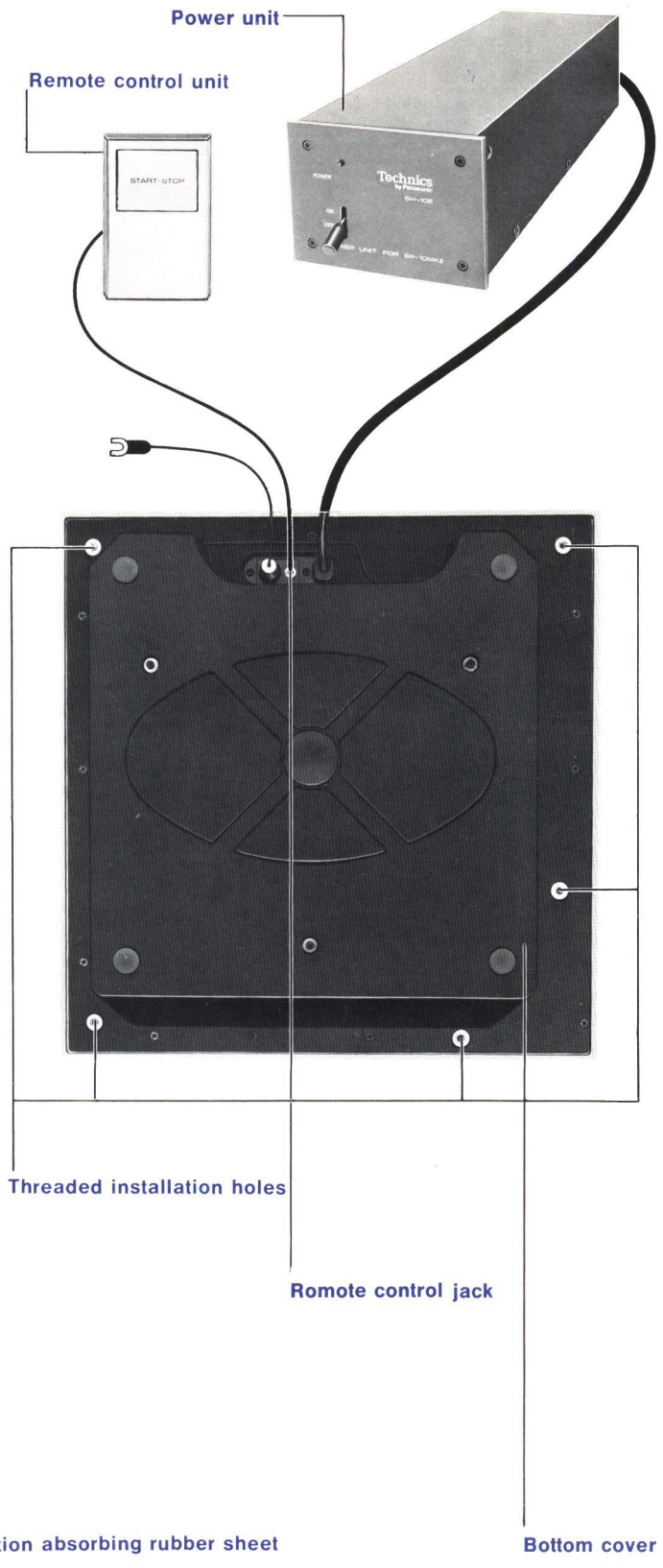
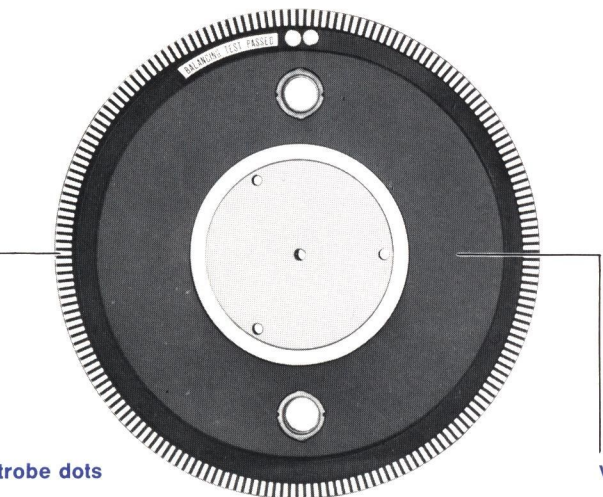
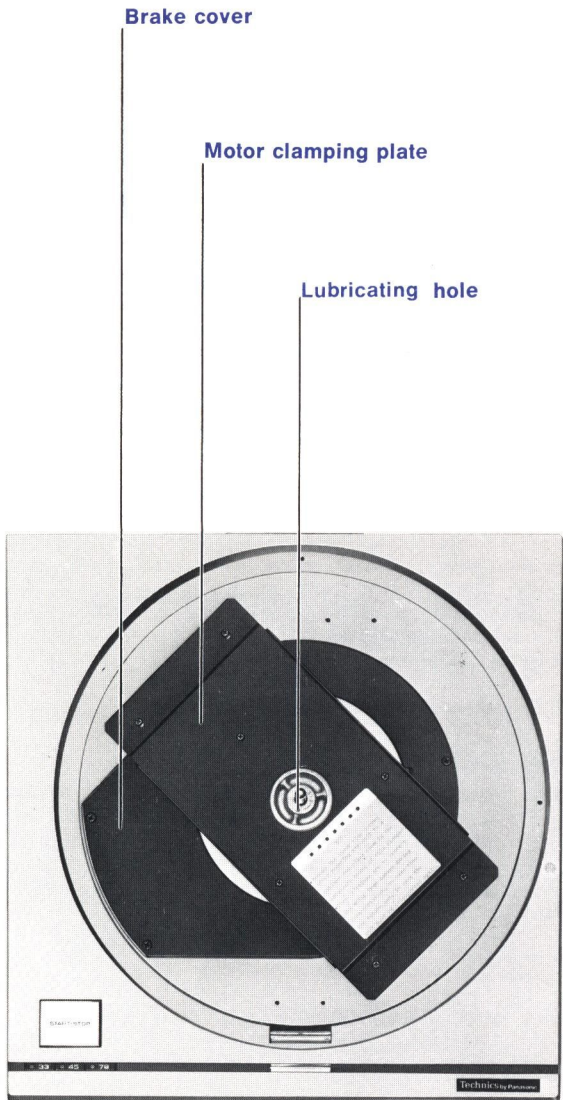

BEFORE USE

1 CHECK TO MAKE SURE YOUR TURNTABLE PACKAGE CONTAINS ALL PARTS LISTED BELOW

Turntable unit	1	Washers	5
Turntable platter	1	Power unit (SH-10E)	1
Turntable mat	1	Remote control unit	
Turntable platter screws	3	(SH-10R)	1
Installation screws		45 r.p.m. adaptor	1
(M5 × 43)	5	Special oil	1
(M5 × 35)	5		

2 APPLY TWO OR THREE DROPS OF OIL TO THE MOTOR SHAFT

Open the tip of the oil vial with a needle and apply two or three drops of oil to the motor shaft.

NOTE:

If oil has leaked out around the rotor of the motor during transportation, wipe it with a lint free cloth.

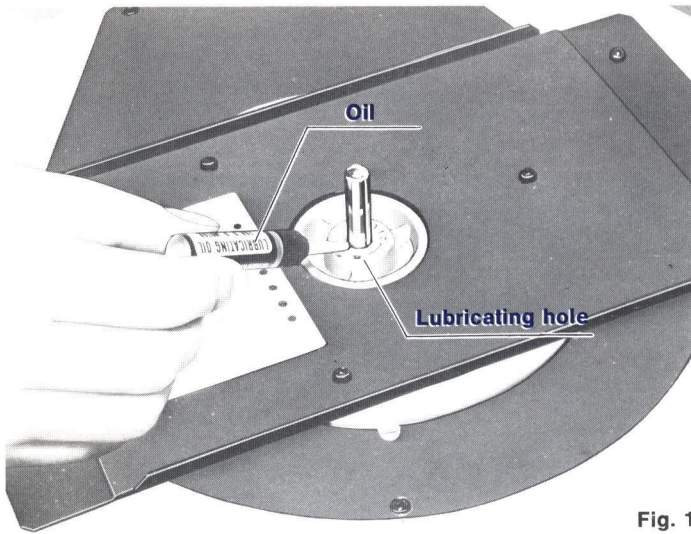

Fig. 1

3 TO PREVENT DAMAGE TO YOUR UNIT DO NOT CONNECT THE AC POWER PLUG TO THE AC SOCKET UNTIL ASSEMBLY HAS BEEN COMPLETED! NEVER CONNECT THE AC POWER PLUG OR TURN ON THE POWER SWITCH UNLESS THE TURNTABLE PLATTER IS ON THE CENTER SPINDLE

ASSEMBLY AND SET-UP

(BUILDING YOUR OWN BASE OR CABINET FOR THIS MODEL)
The starting torque of this model is 6kg · cm (5.2lbs. in.). Thus the turntable platter which is heavy(2.9kg 6.4lbs.) and large (32cm 12-19/32 inches) can be started and stopped quickly. For this reason we recommend that you use durable and heavy material. The thickness of the base should be 3cm(1-11/64inch).

NOTE:
Use durable and stable insulators(legs). Figure 2 shows an example of cabinet construction.

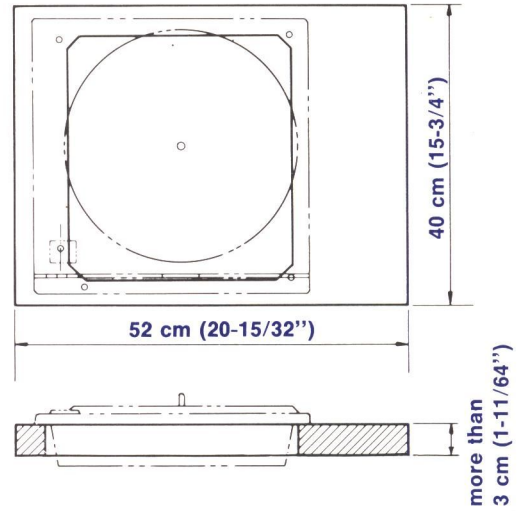

One example of cabinet construction

Fig. 2

1 DRILL AND CUT OUT THE BASE ACCORDING TO THE INSTALLATION DIAGRAM

The installation diagram is drawn in 1/1 actual size.

As paper has a tendency to stretch we suggest that you check the diagram before using it as a template. Also check dimensions for printing errors. Check the tonearm mounting position for proper alignment (follow the tonearm manufacturer's specifications). Also make sure to allow sufficient clearance for power connector and output terminals of the tonearm.

2 INSTALL THE UNIT IN THE CABINET

Two kinds of screws are included in the carton. Use the proper length of screw according to the thickness of the cabinet which you use. When you install the unit in the cabinet place protective material, on top of the unit to protect the center spindle from external damage. A soft cloth placed on the panel surface will protect it from scratches.

3 REMOVE THE MOTOR CLAMPING PLATE AND SCREWS

After installation of the unit in the cabinet remove the seven blue screws and motor clamping plate.

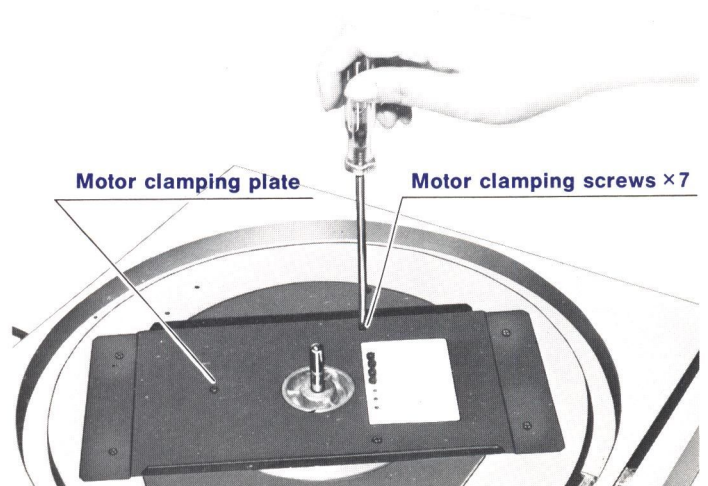

Fig. 3

PLACEMENT

NOTE:

To protect the very delicate and important parts of the motor (spindle, motorshaft etc.) from external damage during transportation protective fittings have been installed. Be sure to remove these fittings carefully and save them for future use in case you again need to transport the unit.

4 SECURING THE TURNTABLE PLATTER

Place the turntable platter on the spindle aligning the holes in the platter with the rotor screw holes by eye. Slightly lifting the turntable platter will make it easier to align the holes. Using the three screws supplied, firmly tighten the turntable platter and put the turntable mat on it.

NOTE:

The turntable platter must be tightened at all three points to assure proper operation.

- 1 Use the unit in a horizontal position and at a stable location, where there is little or no vibration.
- 2 Use the unit as far away from the speakers as possible and isolate the unit from sound radiating from them. If the speakers are placed too near the unit, sound vibrations may be transmitted to the unit or the tonearm and result in "HOWLING" feedback.
- 3 Do not place the unit where it is exposed to direct sunlight, dust, moisture or heat. Also keep it away from heating equipment.

CONNECTION

CONNECTING EACH POINT

Plug the DC connector of the turntable unit into the socket of the power unit. It will lock with a clicking sound.

Plug the power unit into an AC voltage outlet of an amplifier. Using a switched outlet will assure that the power unit will be turned off when the amplifier is turned off.

Connect the ground wire to GND or the chassis of an amplifier.

NOTE:

The SP-10MKII is designed to be used with 120 volt AC power. Although it includes a voltage regulating circuit, it should be used with the specified AC voltage in order to retain its rated performance.

Push the connector lock-pin when you want to remove the DC connector. (Fig. 6)

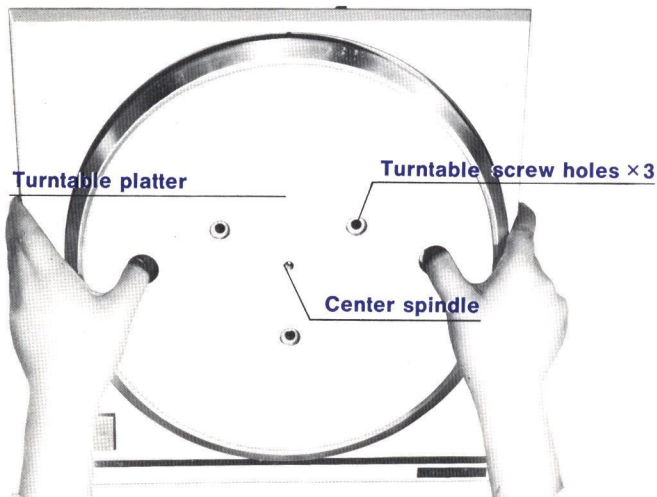

Fig. 4

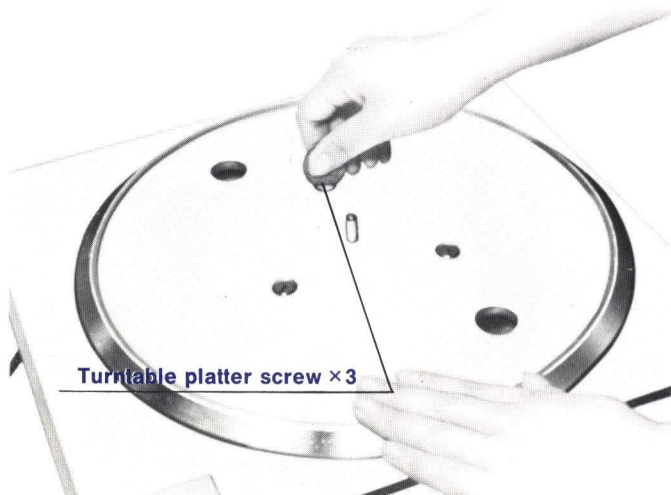

Fig. 5

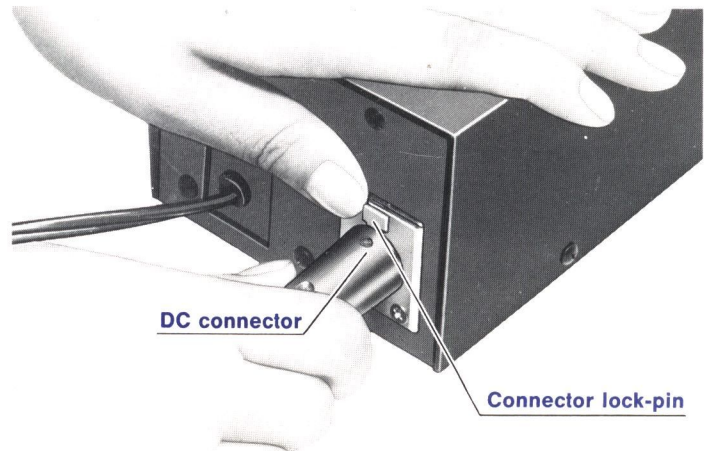

Fig. 6

OPERATING PROCEDURE

1 Turn on the switch of the power unit. The pilot lamp of the power unit, the speed change switch for 33-1/3 r.p.m. and the stroboscope will all light up.

2 Push the speed change switch lightly for the speed of the record you wish to play. The LED (light-emitting diode) lamp will go on signaling the speed selected.

3 Push the start/stop switch. The turntable platter will begin to rotate and reach its constant rotation speed within about 0.25 sec. (or a platter rotation of 25° at 33-1/3 r.p.m.)

4 In order to stop the rotation of the turntable platter push the start/stop switch lightly. Electrical and mechanical breaking systems bring the turntable platter to a complete stop within about 0.3 sec. (or a platter rotation of 30° at 33-1/3 r.p.m.)

NOTE:

When not in use for long periods of time turn the switch of the power unit off.

If the power of the turntable is turned off before actuating the start/stop switch, the braking system will not work. In this case the turntable platter will continue rotating for some time by its own inertia. When the power is turned on again the speed change switch will automatically reset at 33-1/3 r.p.m.

The remote control unit can operate the start/stop switch but it cannot turn the power on and off.

Power unit (SH-10E)



Turntable (SP-10MKII)



Remote control unit (SH-10R)

OPERATING FUNDAMENTALS OF THE SP-10MKII

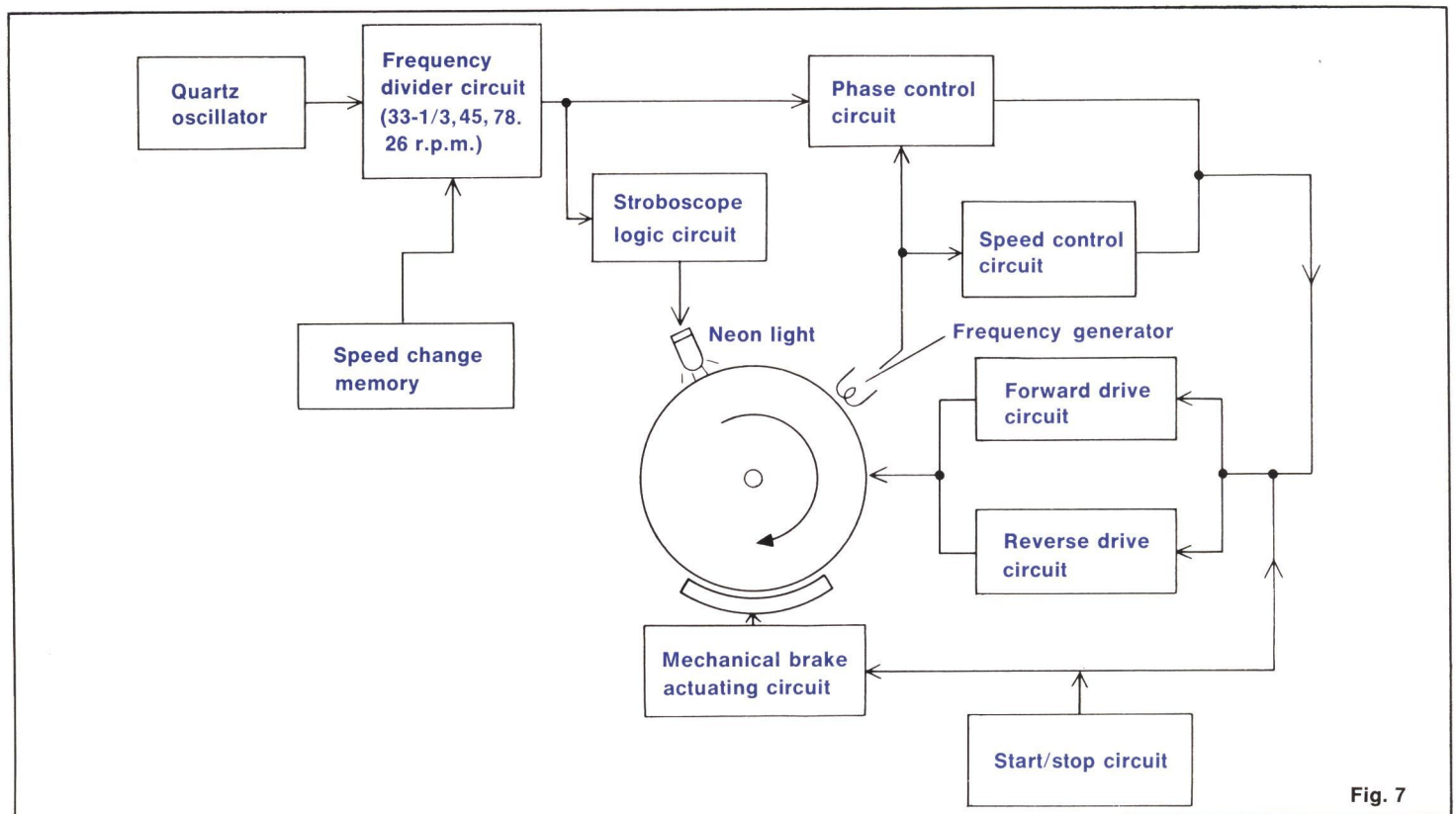

Fig. 7

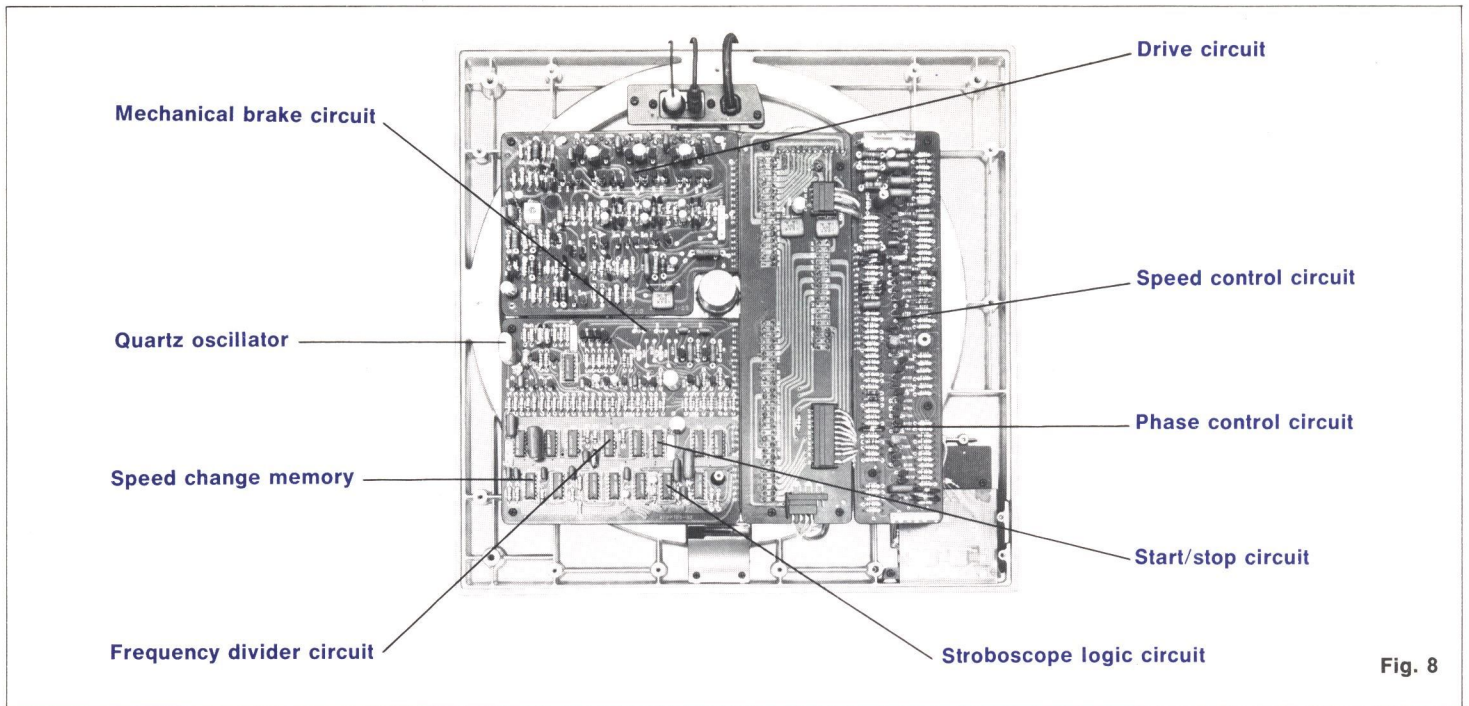

Fig. 8

The stable and highly accurate rotation of the SP-10MKII is obtained with analog-digital circuitry using the latest electronic technology.

QUARTZ GENERATED REFERENCE SIGNAL

The quartz reference signal generator provides a reference signal which controls the action of the SP-10MKII. The oscillation of a quartz crystal is used. This oscillation is stable, highly accurate and not affected by temperature and other changes. The signal generated by the reference signal generator is split by the frequency divider into the appropriate frequency according to the speed selected. The frequency divider is controlled by pushing the speed selector on the front panel of the turntable. The selected speed information is stored in the speed change digital memory.

STROBOSCOPE LOGIC CIRCUIT

The stroboscope lights up the 190 stripes engraved on the platter rim. A neon lamp flashes according to instructive pulses from the stroboscope logic circuit. The circuit shapes digitally the signals from the frequency divider. This provides a sharp strobe image which is independent of external power source frequency.

FREQUENCY GENERATOR

A frequency generator is integrated with the platter drive motor. Its electromagnetic structure using a push-pull design cancels external induction. It converts the platter rotation speed into a frequency. The output of the frequency generator is fed to the speed and the phase control circuits.

SPEED CONTROL CIRCUIT

The speed control circuit includes a sample-hold circuit, which converts the output of the frequency generator into an electrical voltage. This is the control voltage which maintains the platter rotation speed.

PHASE CONTROL CIRCUIT

The phase control circuit detects a phase difference between a reference signal and a frequency generator signal and generates a control voltage. This circuit makes it possible to lock the rotation of the turntable platter to a reference signal. It improves considerably speed stability and speed control characteristics for various load conditions when compared with the conventional direct-drive motor having only speed control as shown in Figure 9.

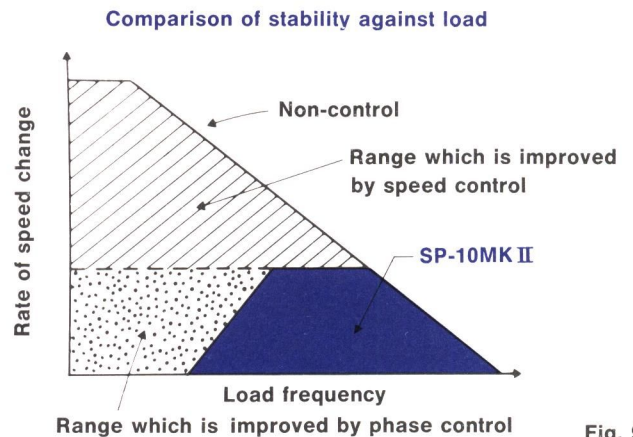

Fig. 9

DRIVE CIRCUIT

Two control signals are composed and applied to the drive circuit to maintain a forward motor-rotation. The drive circuit supplies full-wave drive current, doubling current efficiency. It supplies drive current in both directions for a symmetrical rotation in either a forward or reverse direction. The drive circuit rotates the turntable platter with quick response and large starting torque.

START/STOP CIRCUIT

When the unit is started by the switch on the front panel or by remote control unit, the start/stop circuit activates the forward drive. When the unit is switched off, the start/stop circuit activates the reverse drive and the mechanical brake actuating-circuits to perform a quick stop action.

MECHANICAL BRAKE ACTUATING-CIRCUIT

The mechanical brake actuating-circuit operates a solenoid plunger which pushes a brake shoe against the platter. Working in conjunction with the reverse drive current, the mechanical brake can bring the platter to a complete stop quickly and smoothly. A half-braking force is maintained after the platter has stopped making it easy to accomplish accurate cueing of a record.

FEATURES

① QUARTZ CONTROLLED ROTATION ACCURACY (Fig. 10)

The SP-10MKII utilizes the oscillation of a quartz crystal as a reference signal or source. This oscillation is not affected by temperature change, power fluctuations. By synchronizing the rotation of the turntable platter accurately to the reference signal, speed drift of the SP-10MKII is held within $\pm 0.002\%$. This means that for a record with a playing time of 30 min. total playing time variation can amount to no more than 0.036 sec. This stable and accurate rotation sets a new standard of precision.

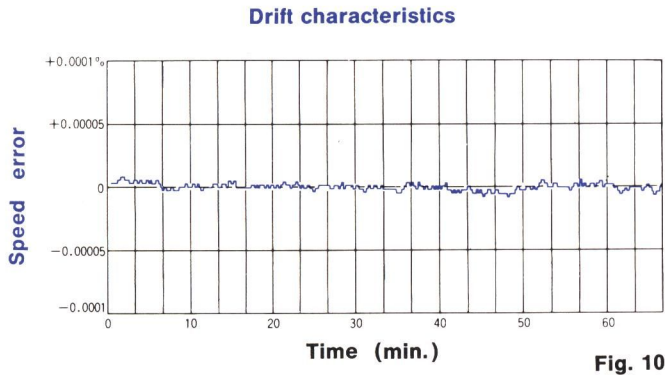

The accuracy under normal operating conditions such as in a listening room is about $\pm 0.00001\%$ as shown in Fig. 10.

② INSTANT STARTING FOR ACCURATE CUEING (Fig. 11) (a build-up time of only 0.25 sec. at 33-1/3 r.p.m.)

In the professional broadcasting world where accuracy is measured in seconds immediate cueing is an important ability of a turntable. The SP-10MKII platter is 32 cm (12-19/32") in diameter and has a moment of inertia of 380 kg-cm² (130 lbs. in²). It can be brought to a rated 33-1/3 r.p.m. within 0.25 sec. A half-braking force is applied to the turntable platter after it is stopped and permits easy cueing of a record. Such fast starting minimizes unpleasant out of pitch music.

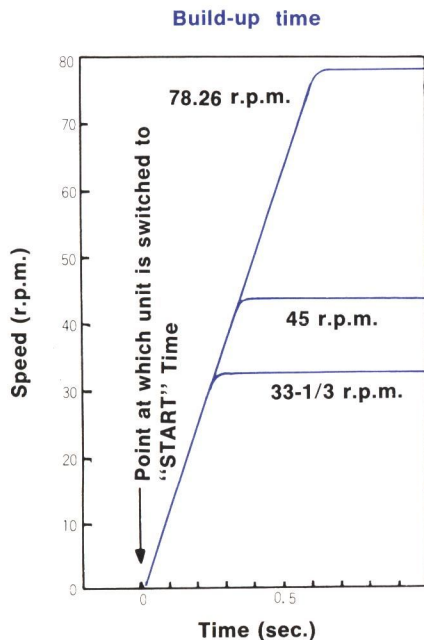

If You Didn't Get This From My Site,

Then It Was Stolen From...

www.SteamPoweredRadio.Com

③ INTEGRATED ELECTRICAL AND MECHANICAL BRAKING (Fig. 12) (a complete stop within 0.3 sec.)

For professional use requiring frequent record changes, instant stopping is a must. The electrical braking system uses reverse rotation of the DC servo motor to slow down the rotation and in combination with the mechanical braking system brings the turntable platter smoothly to a complete stop within 0.3 sec.

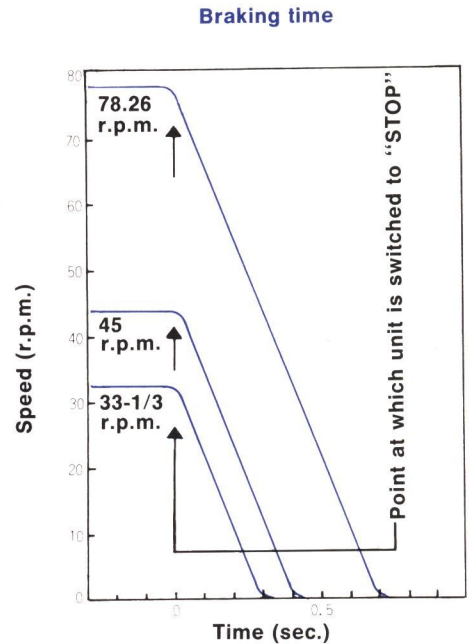

④ INSTANT SPEED CHANGE (Fig. 13) (a build-up time of only 0.4 sec.)

The SP-10MKII operates at the professionally used speeds of 33-1/3 45 and 78.26 r.p.m. The speed is changed electrically and the switch incorporates an LED indicator. A large torque and an electrical braking system make it possible to change to any of the 3 speeds in a fraction of a second.

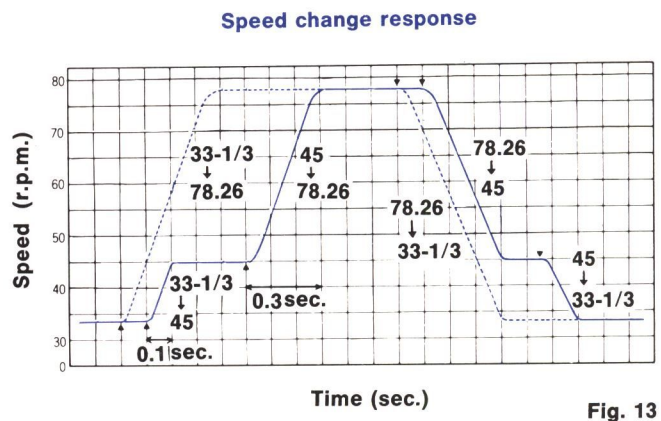

⑤ STABLE LOAD CHARACTERISTICS (Fig. 14)
(normal rotation with up to 1 kg tracking force.)

The quartz phase-locked control system and the DC servo motor with large torque can maintain each rated speed of the turntable even with a load torque of up to 5 kg-cm (4.3 lbs. in). If 500 tone-arms of 2 gr. tracking force were placed on a record at the same time the turntable would still maintain each rated speed.

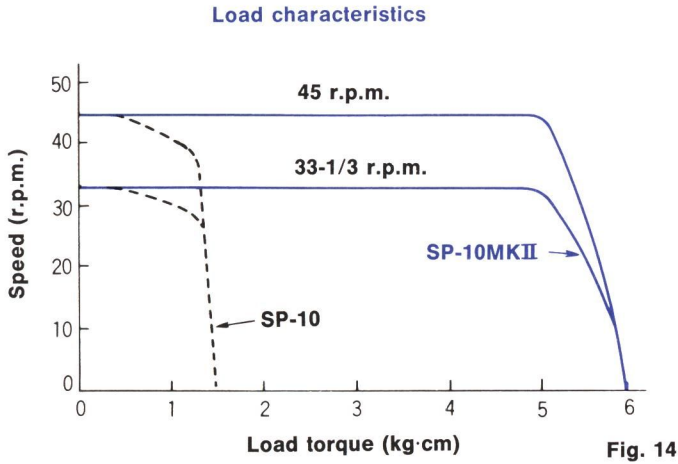

Fig. 14

⑥ BRIGHT CLEAR AND ACCURATE QUARTZ CONTROLLED STROBOSCOPE (Fig. 15)

If commercial AC power were used for the stroboscope its accuracy would be influenced by power frequency fluctuations of about 0.2%. In the SP-10MKII the stroboscope neon lamp is lighted using the reference signal of the quartz oscillator which maintains stable oscillation. Thus a different set of marking stripes is not necessary for different commercial power line frequencies or different speeds. Wave shaping by the strobe-logic circuit makes the stroboscope bright and clear.

Fluctuation in commercial power line frequency (60 Hz)

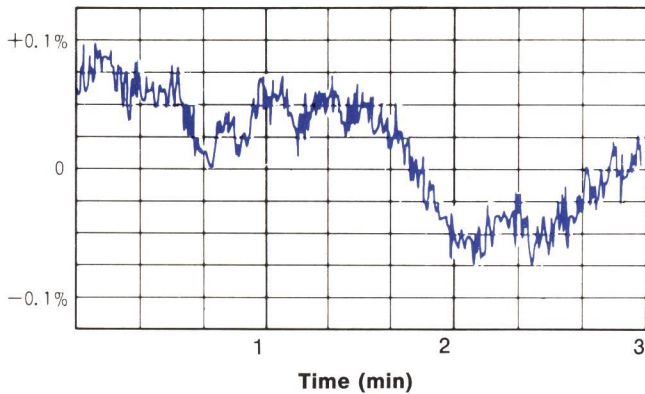

Fig. 15

⑦ RUMBLE AND WOW & FLUTTER CHARACTERISTICS EXCEED THE RECORDS CAPABILITIES (Fig. 16 and 17)

Technics developed the SP-10 which was introduced to the audio world in June of 1969. The excellent rumble and wow & flutter characteristics of the Technics DC servo motor have been appreciated by the public. This technology has been further refined. The SP-10MKII has rumble of -50 dB (DIN 45539A), -70 dB (DIN 45539 B) and wow & flutter of 0.025% W.R.M.S. (JIS C5521). These characteristics exceed the maximum performance capabilities of any record presently on the market.

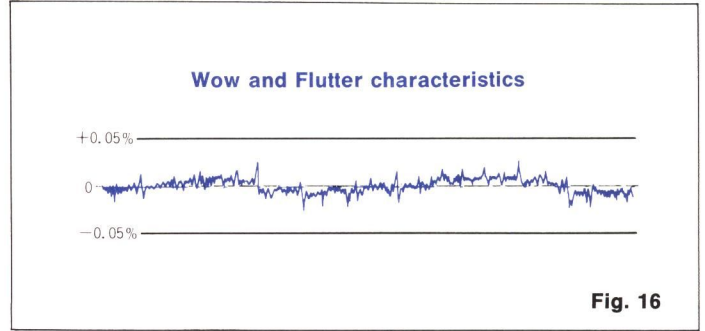

Fig. 16

Frequency spectrum of rumble

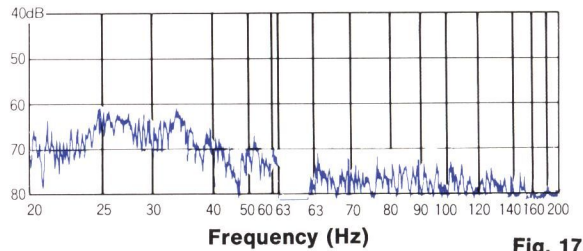

Fig. 17

NOTE:

The rumble characteristics were measured using an original lacquer disc having the same groove shape as a standard record (grooved at a 45/45 degree angle).

⑧ PLAYER SYSTEM ADAPTS TO YOUR REQUIREMENTS

(a new standard of precision and excellence in performance for the user.)

According to your requirements a superior player system can be built around this high-performance turntable which has set a new standard of precision. The function of the system can be enlarged through the use of the remote control unit which is included. This hand held unit permits instant start/stop operation.

SPECIFICATIONS

Type	Direct-drive quartz phase locked turntable	Speed fluctuation with load changes	0% within 5 kg·cm (4.3 lbs·in)
Turntable platter	Aluminum diecasting, diameter 32 cm (12-19/32 inches) weight 2.9 kg (6.4 lbs.), moment of inertia 380 kg·cm ² (130 lbs·in ²)	Speed drift	Within ±0.002%
Motor	Brushless (electronic rectification) DC motor	Wow & Flutter	0.025% W.R.M.S. (JIS C5521) ±0.035% Weighted, zero-to-peak (DIN45507)
Platter speeds	33-1/3, 45 and 78.26 r.p.m.	Rumble	-50 dB (DIN 45539A) -70 dB (DIN 45539B)
Starting torque	6 kg·cm (5.2 lbs·in)	Power supply	120 V, AC 50 or 60 Hz
Build-up time	0.25 sec. (25° rotation) to 33-1/3 r.p.m.	Power consumption	20W
Braking time	0.3 sec. (30° rotation) from 33-1/3 r.p.m. to standstill	Dimensions	10.25 × 36.85 × 36.85 cm (H × W × D) (turntable only) 4-1/64 × 14-31/64 × 14-31/64 inches
		Weight	9.5 kg (20.9 lbs.) (turntable only)

Matsushita Electric Corp. of America
1 Panasonic Way, Secaucus, New Jersey, 07094.
Matsushita Electric of Hawaii, Inc.
320 Waiakamilo Road, Honolulu, Hawaii 96817
Matsushita Electric of Canada Ltd.
40 Ronson Drive, Rexdale, Ont, M9W 1B5 Canada

Installation diagram for SP-10MKII 1/1mm (inch)



Please Note:
 This One To One Scan Was Made By
 Scanning The Original On A 121x17 Scanner
 And Then Piecing* The Individual Parts Together.
 Due To Errors In Scanning, Assembly And Your
 Printer, I Cannot Guarantee That It Is The Same
 Size As The Original. Please Use The Dimensional
 Data In The Drawing To Align Your Mounting Holes.

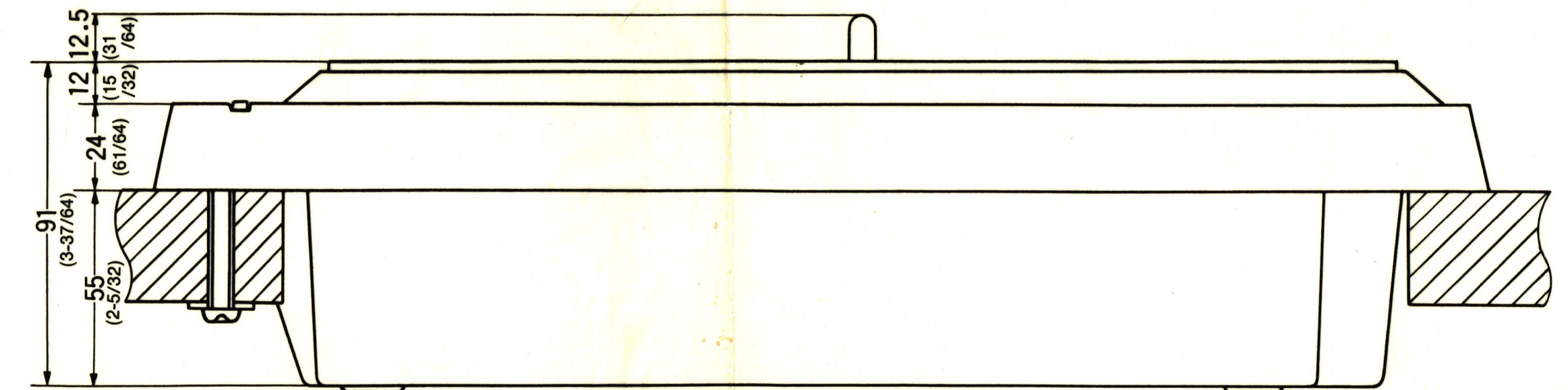
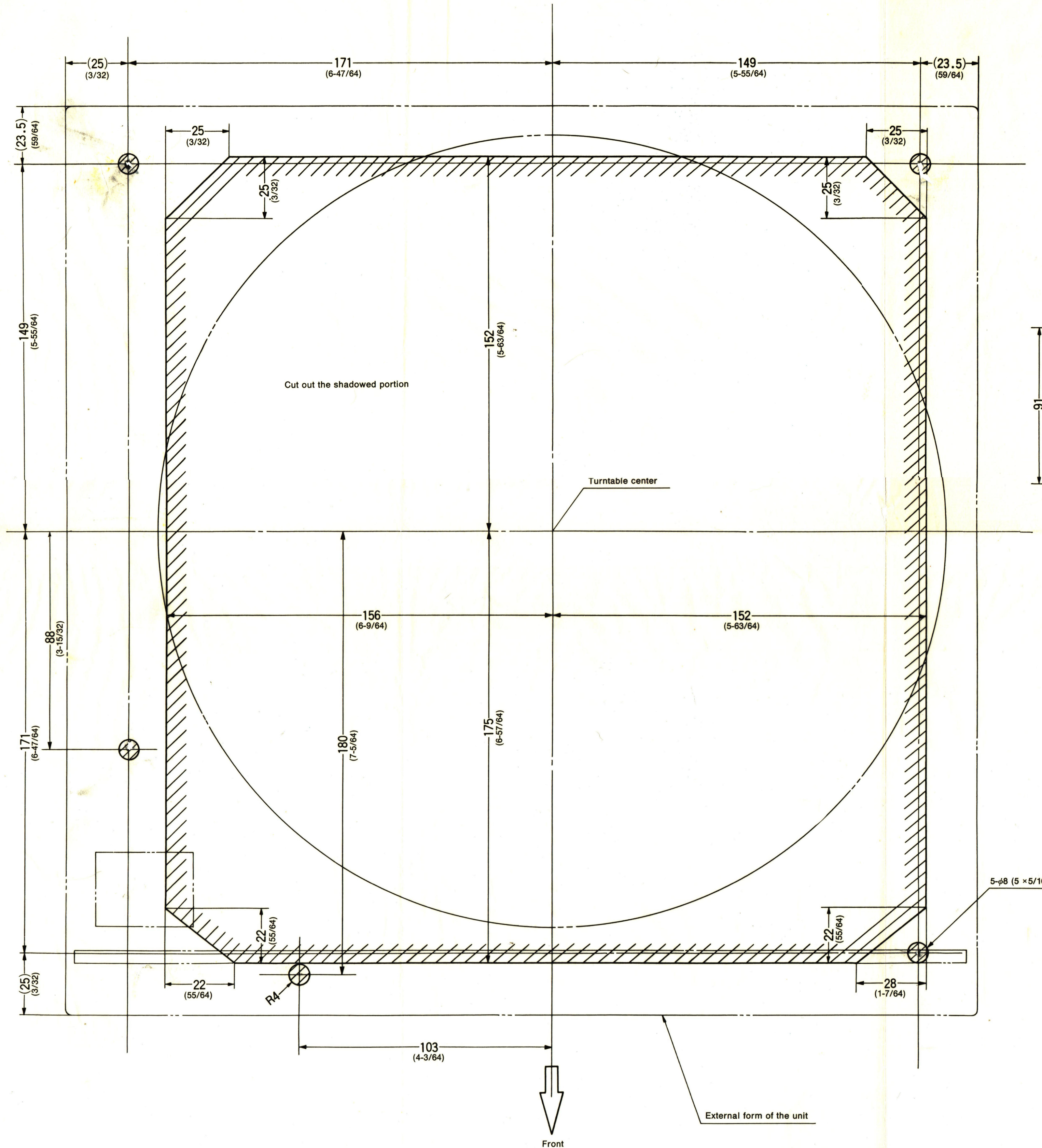

NOTES:
 The accessory screws to install the unit in a cabinet are designed for use with a cabinet board of 30 to 35 mm (1-11/64 to 1-3/8 inch) in thickness.
 For a cabinet board of different thickness, use screws suitable to that thickness. (The accessory screw is a meter screw with a nominal diameter of 5 mm (3/16 inch) and a pitch of 0.8 mm (1/32 inch). Use thick and heavy material for the cabinet in order to bring out the best performance of the turntable.
 This installation diagram is drawn in 1/1 natural size, but the demensions may be incorrect because of a shear in printing and paper expansion and contraction, so use the figures described in the installation diagram for processing of a case and others.

If You Didn't Get This From My Site,
 Then It Was Stolen From...
www.SteamPoweredRadio.Com

*Piecing Doesn't Look Right To Me
 But That Is What The Spell Checker Says.
 And What The Spellchecker Wants,
 The Spellchecker Gets.

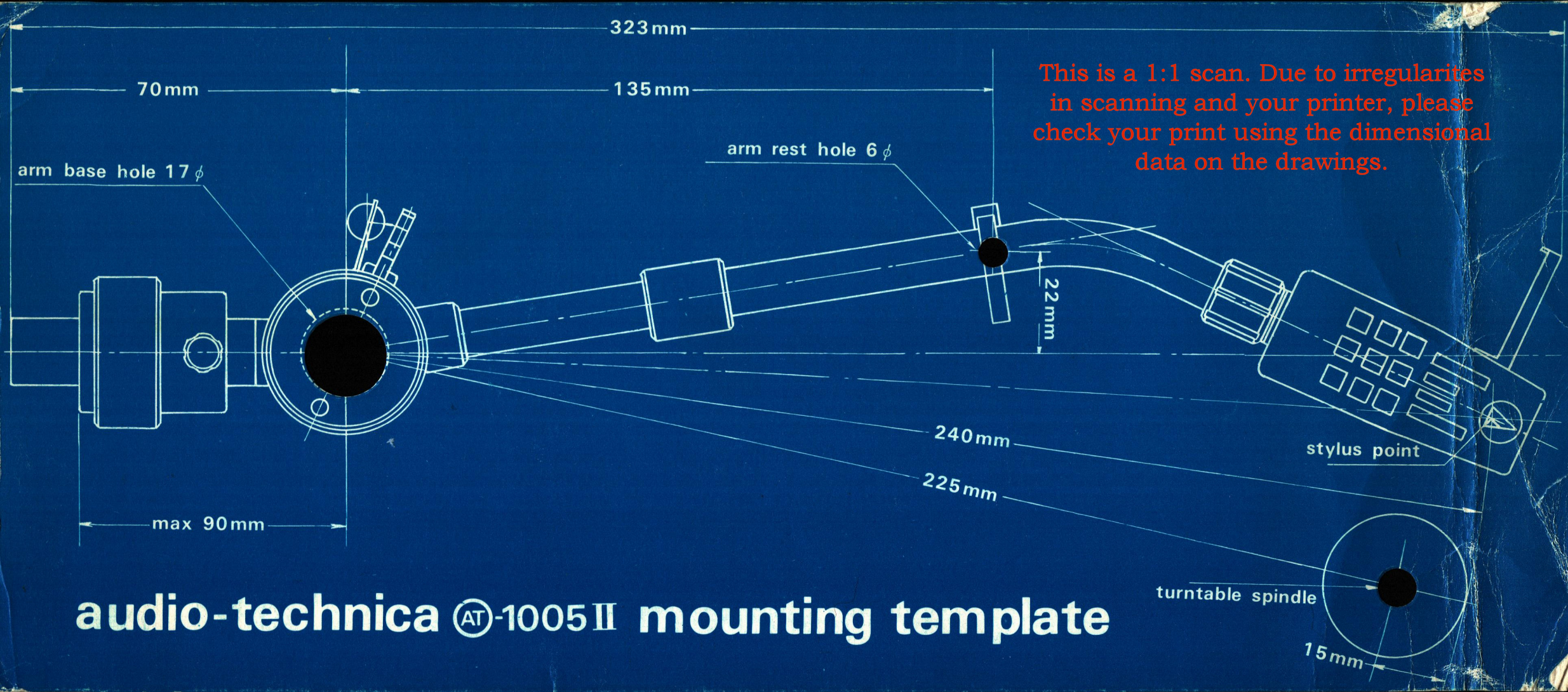

audio-technica AT-1005 II mounting template

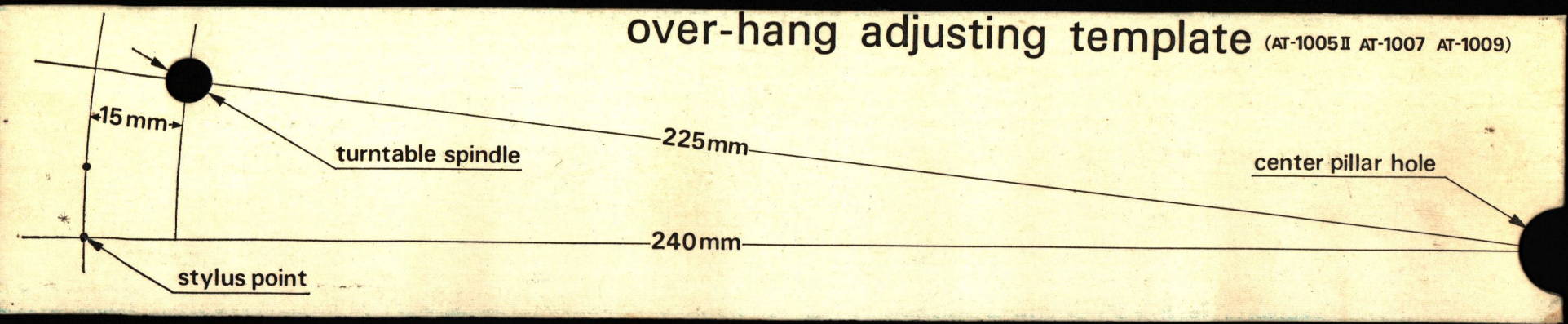

235mm

TURNTABLE CENTER

UNIVERSAL TONEARM

EPA-100 TEMPLATE

EPA-100	250 mm	15 mm	5g ~ 10g
SPECIFICATIONS	EFFECTIVE ARM LENGTH	OVERHANG	CARTRIDGE WEIGHT

TRACKING ERROR ANGLE (°)

RECORD RADIUS (mm)

DAMPING SELECTOR CALIBRATIONS

CARTRIDGE COMPLIANCE (x10⁻⁶ cm/dyne)

CARTRIDGE WEIGHT (INCLUDING HEAD SHELL)

- ⊙ B₃ (15.5g)
- ⊙ B₂ (17.5g)
- ⊙ 10₃ (19.5g)

COMPLIANCE AT 10 DYNAMIC COMPLIANCE (100Hz) STATIC COMPLIANCE

MAKE Ø38mm MOUNTING HOLE

SFP-ZB10005

www.SteamPoweredRadio.Com